



Linear and Motion Solutions

Linear guide system



EP 2406 E

Linear guide systems



NADELLA

Summary

GU System	Sand blasted guide rails GU..MT
	Ground guide rails GU..M
	Guide Rollers RKU
	Guide Wheels FKU
ROLBLOC System	Sand blasted guide rails GU..MT
	Ground guide rails GU..M
	Guide Rollers ROLBLOC
FS System	Sand blasted guide rails FS..MT
	Ground guide rails FS..M
	Sand blasted guide rails FSH..MT, FSX..MT
	Ground guide rails FSH..M, FSX..M
	Sand blasted socket guide rails FSB..MT
	Guide Rollers FR..EI
	Guide Rollers FRN..EI
	Guide Rollers RKY, RKX
	Guide Wheels FKY, FKX
	Floating Guide Rollers FRL
Floating Guide Rollers FRLK..FRLR	
GP System	Guide rails GP..ML
	Ground guide rails GP..M
	Guide Rollers PK
	Guide Wheels FK
	Guide Rollers GC

	page	
	16	For medium-heavy loads
	16	
	17	
	18	
	22	For medium-heavy loads Dirty environment
	22	
	23	
	28	For all applications
	29	
	30	
	31	
	32	
	33	For light-medium-loads
	34	For light-medium loads with shocks
	37	For medium-heavy loads
	38	For medium-heavy loads
	35	
	36	For light-medium loads
	42	For medium-heavy loads Dirty environment
	43	
	44	
	45	
	46	

Summary



DC, C systems	Guide rails DC
	Guide rails C
	Guide Rollers PFV
	Carriages T4PFV
	Wipers NAID
FWS, FWH systems	Guide rails FWS
	Guide rails FWH
	Guide Rollers FR..EI
	Guide Rollers FR
	Guide Rollers FR..-AS
	Guide Rollers FR..-AZ
LM systems	Guide rails LM
	Guide Rollers RCL, RCP, PFV
	Floating Guide Rollers RAL
	Guide Wheels GLA
	Carriages C3RCL, C4RCL
	Carriages T4RCL, T4RCP, T4PFV
	Wipers RS

page

	50	For medium loads Aggressive environment
	51	
	52	
	53	
	54	
	56	For light-medium loads
	57	
	58	
	59	
	60	
	61	
	68	For light-medium loads
	69	
	70	
	71	
	72	
	73	
	73	

Nadella Linear System

With this line of products, NADELLA confirms the aim to provide manufacturing solutions tailored to the user's needs in order to achieve simple automation at a low cost.

The process under way of transferring production automation and relevant handling onto increasingly heavier and cumbersome units has prompted us to seek original and flexible components for the different commodity sectors.

We have accumulated sound working experience in the following sectors:

- marble-working machinery
- foundry machinery
- metal sheet working machinery
- special lifting machines
- pick up
- automatic warehouses
- textile machines
- machine tool protections and utilities
- oxygen cutting machines

Our Technical Department works with Customers and recommends the best component choice by making the calculations needed to determine the best life.

Guides

Length

The maximum length of each single guide component is shown on the dimensional tables.

The standard lengths of the rails are determined by adding the product of the fixing hole centre distance and the number of holes to twice the end dimension (see dimensional tables).

The following table provides the standard length tolerance.

Length	≥ 150 < 420	≥ 420 < 1.050	≥ 1.050 < 2.040	≥ 2.040 < 4.020	≥ 4.020 < 5.280
Length tolerance	±0,5	±0,8	±1,2	±2	±2,5

Joints

For strokes of greater length, the guide components can be joined after grinding the end faces (suffix R or RR). To maintain the hole centre distance tolerance, when ordering always specify the number of individual rails making one continuous length.

Please specify in the order when rails have to be matched.

Fixing holes

The guides are available with standard holes, as shown in dimensional tables, with special hole layout or without holes (see order code referencing)

Standard tolerance for hole position is $\pm 0,25$ mm

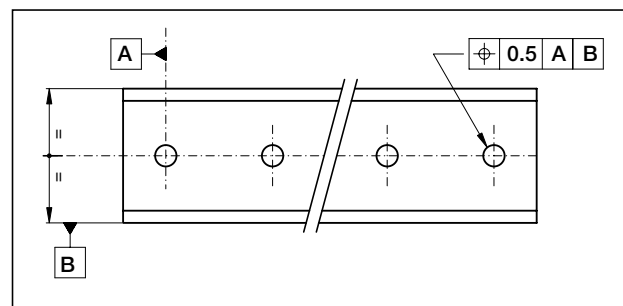

Steel guides

General

Steel rails are made of bearing steel to give best stability and durability. Raceways are induction hardened to achieve 58 HRC hardness minimum. The rail core remains soft to allow easy machining. Rails can be provided with different finishes to meet specific application requirements.

Guide rails MT type. Profile is produced by cold drawing process, raceways are induction hardened and sandblasted to improve surface strength and finish.

Guide rails M type. Profile is usually produced by cold drawing process, induction hardened on raceways and ground to improve surface finish and profile geometry and **to remove the partially decarburised surface** (0.1 mm max on cold drawn rails ..MT). Ground rails have to be used when there are high loads, heavy-duty cycles or when there is a high accuracy requirement.

Guide rails ML type (flat rail GP.ML only). ML rails are produced by drawing process and induction hardened. Partial decarburising can be deeper than in cold drawn rails MT type according to dimensions.

Options

Corrosion protection

For use in oxidising environments or in the presence of corrosive agents, the guides are available with chemical nickel-plating protective anticorrosion treatment (suffix NW.).

This treatment features substantial mechanical characteristics together with a resistance to mist corrosion superior to that of hard chrome.

Circular rail

On request circular rails can be provided. Circular rails can be used as an alternative to rotating devices or as junction between straight rails.

Technical features

Standard rail straightness (for non-mounted rails) is 0.5 mm/m max. Higher accuracy can be supplied on request.

Temperature

Standard operating temperature range is -20°C up to 150°C . In lower or higher temperature applications please contact Nadella Technical Service. Special care is required if guide rollers are operating at maximum temperature.

Aluminium guides

General

Made by joining an aluminium alloy support element and hardened steel rods that form the sliding surfaces.

The best features of the two materials and relevant working technologies are combined to give the lightness of the alloy and the hardness and surface finish of the rods.

Guides of this type can be used for structural functions; they have a high moment of inertia that enables them to be used in many applications as carrying structures.

Aluminium extruded profiles are stabilised and anodised.

Sliding rods are induction hardened and ground.

Options

Corrosion protection

For use in oxidising environments or in the presence of corrosive agents, the guides of this series can feature stainless-steel bars (suffix NX).

Chromium-plated rods

Optional chromium-plated rods are available (suffix CH); the thickness of the chromium plating is $10 \pm 5 \mu\text{m}$ with hardness $\geq 800 \text{ HV}$.

Please check option availability in dimensional tables

Joints

In case rail made by multiple C-DC or LM rails the most efficient joint can be realized with the insertion of a dowel pin inside the rods. This solution allows for simple assembly at the site and maintains alignment under load.

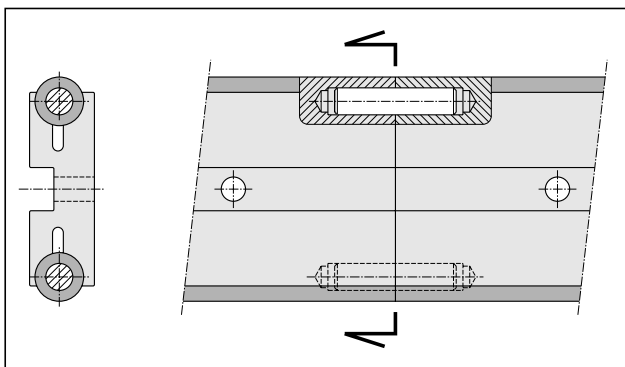

In case of FWS the joint is produced with dowel pins. When using dowels the joints abut each other. Without a dowels there is a small gap.

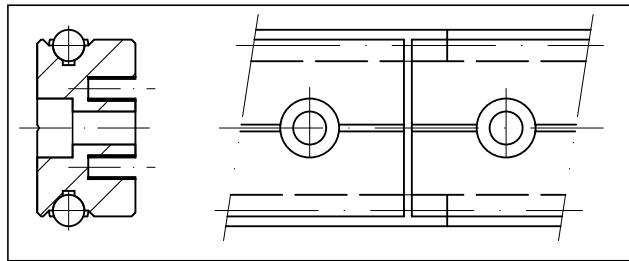

Technical features

Standard rails straightness (for non mounted rails) is 0.5 mm/m maximum. Higher accuracy can be supplied on request.

Temperature

Standard operating temperature range is -20°C up to 70°C . Applications with frequent temperature variation should be avoided. For operating conditions outside the given range please contact Nadella Technical Service

Guide rollers

General

Nadella provide a wide range of guide rollers to be able to meet different technical and economic requirements.

All guide rollers are produced in concentric and eccentric versions to allow backlash adjustment during assembly on final equipment. Eccentric rollers are identified by additional R in the code.

The sides of the races of the guide roller, except guide rollers FR,FR..AS,FR..AZ, are slightly convex. Besides reducing rolling friction, this also permits offsetting slight guide flexing or small assembly alignment errors.

Guide rollers are fitted with seals for bearing protection and lubricant retention as described in dimensional tables.

Guide rollers based on **needle or tapered roller bearings** (FRN..EI,RK..,PK..) are recommended for critical applications with heavy axial loads and/or shock loading. Guide rollers based on **ball bearings** (FR..FR..EI,RCL) are more suitable for lighter loads or high dynamic systems.

When mounting guide rails opposite to each other with connected carriages, as shown in the sketch, a high level of parallelism between the guide rails is required when axially rigid rollers are used.

To avoid operating problems it is recommended to use axial rigid fixed rollers on one carriage e.g. FRN/FRNR...EI and axial movable rollers on the other carriage e.g. FRLK/FRLR.

Movable rollers allow a little misalignment between the opposite mounted guide rails.

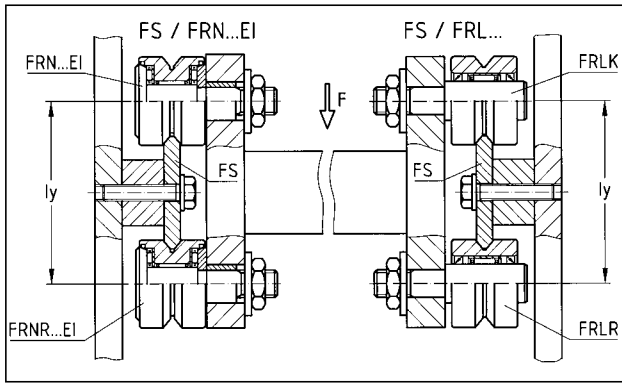

Another solution is to use one profiled guide rail e.g. FS and on the opposite side a flat rail e.g. GP in connection with rollers GC or PK.

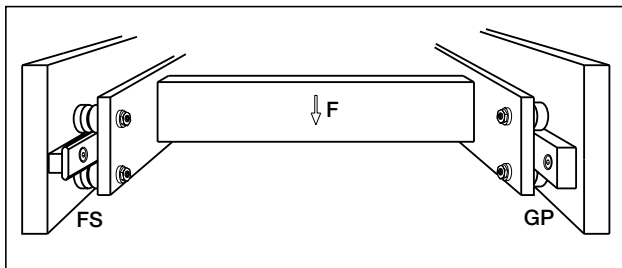

Technical features

Lubrication

Guide roller FRN..EI permits bearing relubrication. All other guide rollers are long life lubricated.

Temperature

Guide roller should not operate at constant temperature above 80°C. For short durations 100°C can be accepted. For higher temperature please see the "option section".

Speed limit

Max velocity has to be determined for each application relevant to the guide roller type, size and load conditions. As general value, in normal conditions maximum speed is 4 m/sec. Contact Nadella Technical service in case of specific request.

Options

Corrosion protection

For uses in oxidising environments or in the presence of corrosive agents, the guide rollers are available in stainless steel (suffix NX). Check in the dimensional table component availability.

High temperature

On request guide rollers can be equipped with Viton seals to operate at temperature up to 120° (suffix V). Check in the dimensional table component availability.

Accessories

Tables and carriages

Standard table carriages for C-DC and LM systems incorporate a black anodised aluminium plate fitted with guide rollers.

Wipers

Standard wipers NAID for C-DC rails and RS for LM rails are made from NBR compound moulded on a steel plate.

Assembly instructions

Guide rollers

The eccentric guide rollers allows the preload or clearance of the carriage to be adjusted independently of the guide roller mounting hole positioning tolerance or the distance between the rails.

Recommended mounting hole tolerance is H7.

When adjusting the eccentric guide roller care has to be taken to avoid excessive preload. Excessive preload can reduce the life of the linear system.

Set the preload turning the guide roller anticlockwise so that any movement caused by vibration will cause the nut to be tightened. Ensure the preload is not increased when tightening the nut.

A simple way of setting a roller preload is as follows:

1. move the slider on the guide, locking the roller being adjusted with two fingers to prevent it rotating
2. increase the preload by means of the wrench
3. repeat stage 1 making sure the roller slides without rolling
4. when it is no longer possible to prevent roller rolling, slightly decrease the preload action and fully tighten the lock nut, thereby setting the position of the eccentric.

When correctly adjusted it is just possible to cause the guide roller to slip on the guide rail when a torque is applied to the roller.

Guides

For single guide rail type FS, FWS, DC and LM no special assembly instructions are necessary. For multiple parallel rails parallelism has to be checked to avoid guide rollers overload or excessive carriage play. When constant preload is required parallelism error has to be lower than 0.050 mm.

Guide rail order code

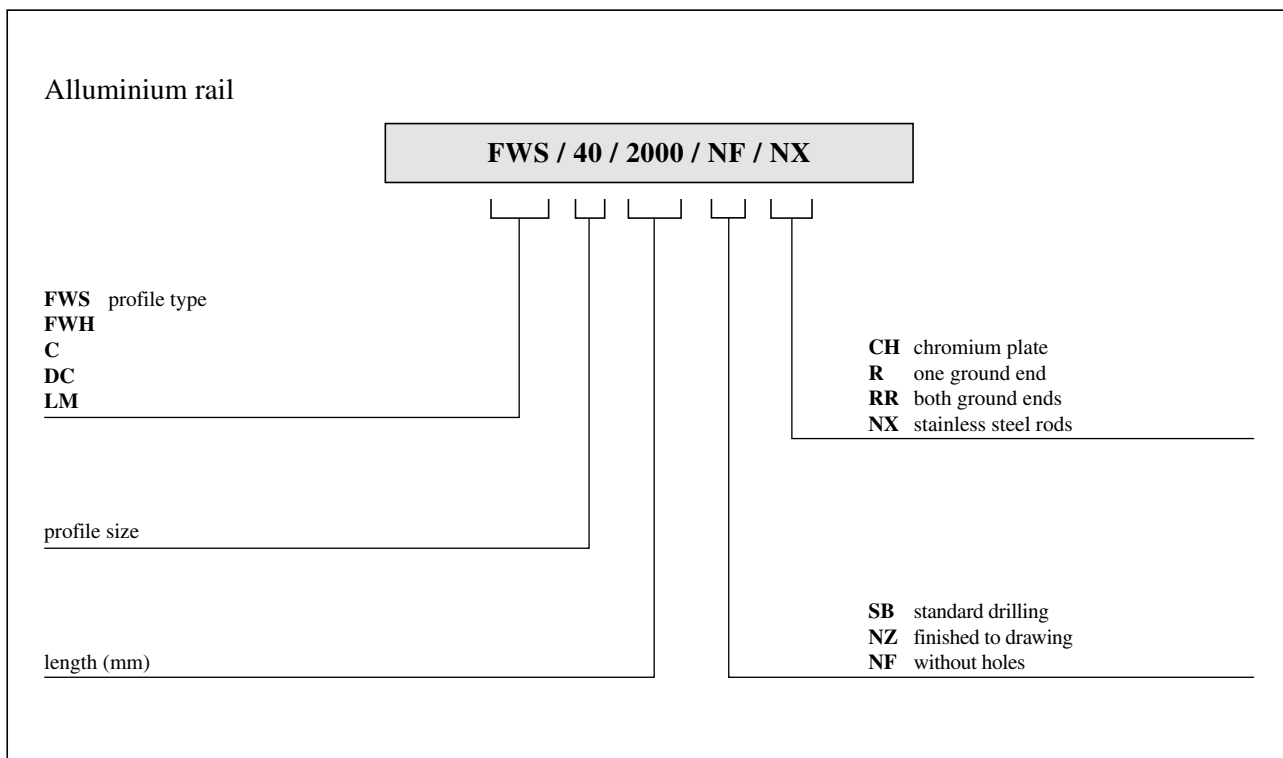
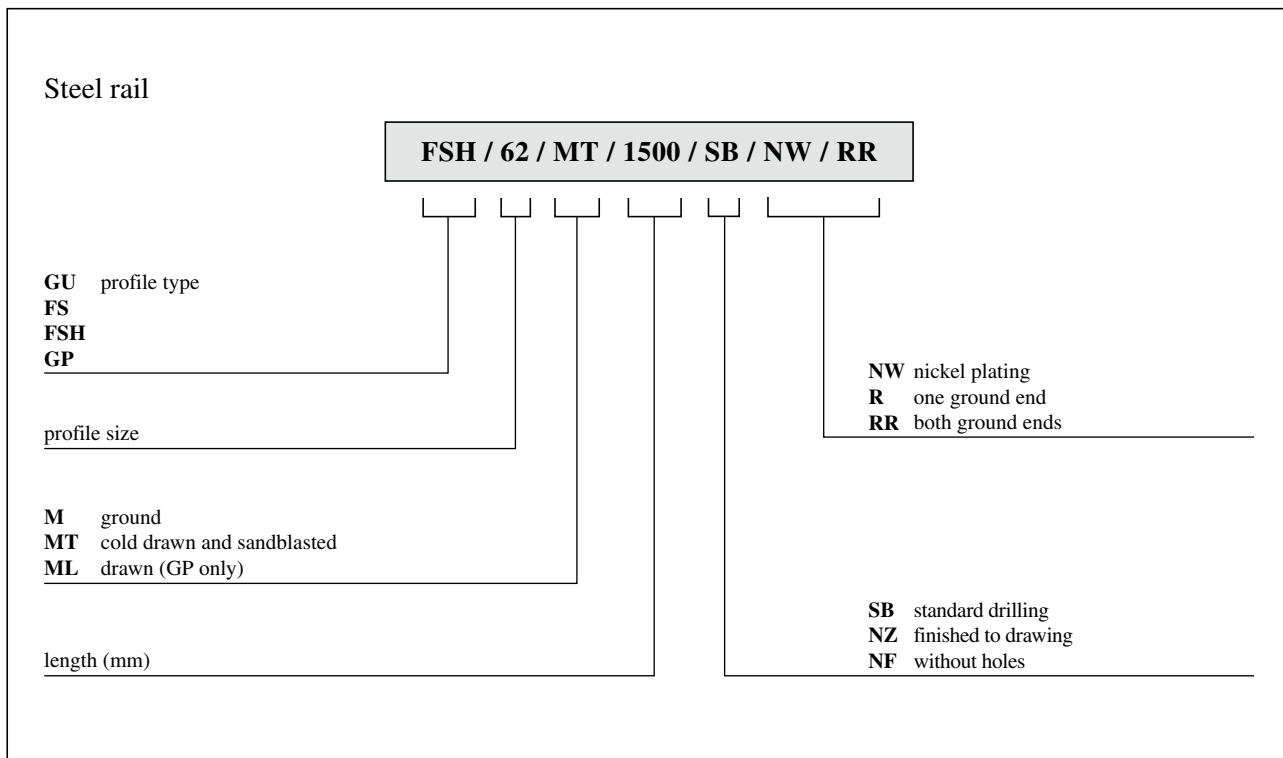

Calculation procedure

Calculation is carried out in two steps, first defining the forces on the most heavily loaded roller and then estimating roller factor of safety and life.

Calculating the loads on the guide rollers

In the case of complex load situations, with forces acting in different directions, calculating the reactions on the rollers is difficult and hard to simplify.

In the event of the applied load having a direction parallel to one of the co-ordinate axes, the radial P_r and axial P_a components of the reactions on the most loaded roller can be obtained using elementary formulas.

With reference to the diagrams shown, we obtain the load components on the rollers relevant for checking and calculating the life, applying the following methods.

Angle α in the formulas is half the groove angle. Look in the dimensional table notes for the correct value.

Distance l_c is the effective contact distance. With the exception of ROLBLOC system the correct value is calculated as the guide rollers centre distance across the rail plus or minus the outer guide roller diameter, depending if the guide is outside or between the rollers.

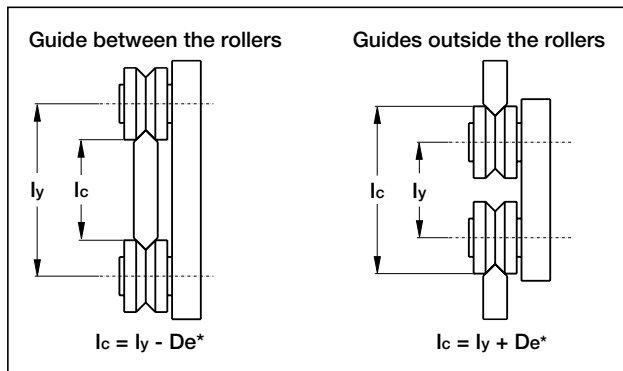

* except guide rollers RKU.

Please contact the NADELLA Technical Service.

In case of ROLBLOC the distance l_c is the distance between the rails basis.

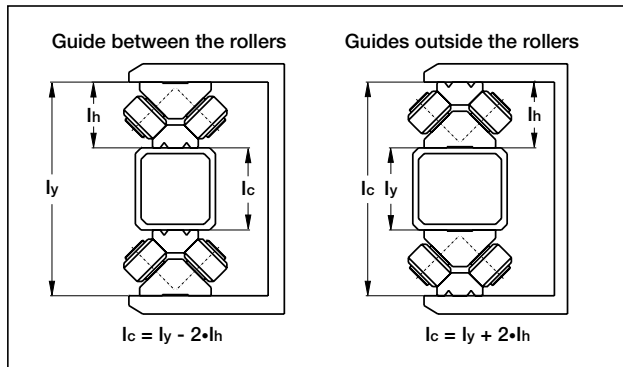
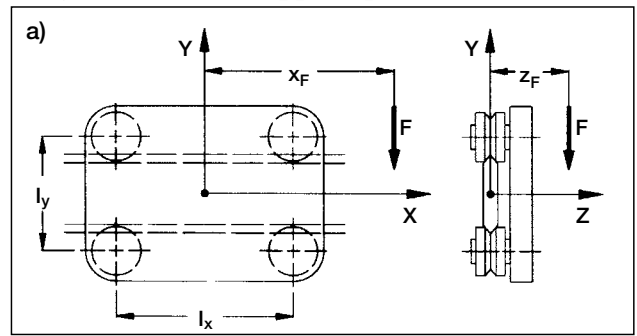

Diagram a) load F applied parallel to axis Y



$$P_a = \frac{F \cdot z_F}{2 \cdot l_c}$$

$$P_r = \frac{F \cdot (l_x + 2 \cdot x_F)}{2 \cdot l_x} + \frac{F \cdot z_F \cdot \tan \alpha}{2 \cdot l_c}$$

Diagram b) load F applied parallel to axis Z

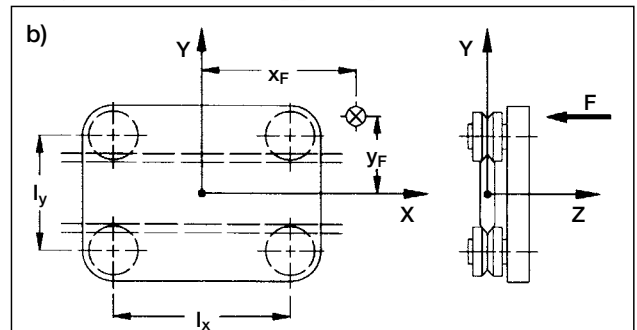

$$P_a = \frac{F}{4} + \frac{F \cdot x_F}{2 \cdot l_x} + \frac{F \cdot y_F}{2 \cdot l_c}$$

$$P_r = P_a \cdot \tan \alpha$$

Diagram c) load F applied parallel to axis X

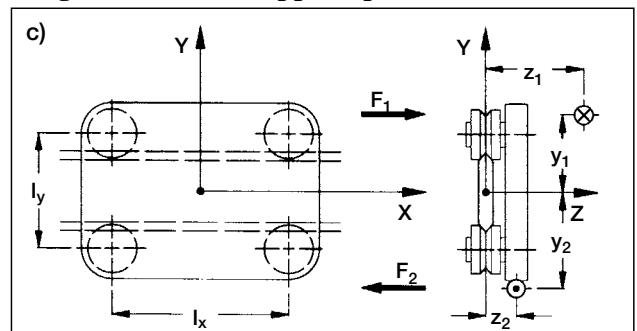

In this case the external load F_1 , applied at the point of co-ordinate $y_1 z_1$, should be considered together with reaction $F_2 = -F_1$, applied at the point of co-ordinate $y_2 z_2$. Calling Δy the absolute value of $y_2 - y_1$ and Δz the absolute value of $z_2 - z_1$, the following formula is used:

$$P_a = \frac{F_1 \cdot \Delta z}{2 \cdot l_x}$$

$$P_r = \frac{F_1}{l_x} \cdot \left(\frac{\Delta z \cdot \tan \alpha}{2} + \Delta y \right)$$

Guide roller calculation

In the table for each roller the following data is specified:

C_w basic dynamic load, it is the radial load [N] that applied to the guide roller gives 100 km nominal life*.

C_{or} bearing radial static load, it is the maximum radial load [N] that can be applied on the guide roller, limited by bearing contact stress.

C_{oa} bearing axial static load, it is the maximum axial load [N] that can be applied on the guide roller.

F_r limit radial load, it is the maximum radial load [N] that can be applied on the guide roller due to the stud strength.

F_a limit axial load, it is the maximum axial load [N] that can be applied on the guide roller because due to the stud strength.

X and Y coefficients to define the equivalent load for bearing life.

α is the contact angle dependent on the guide roller type.

Rollers FRN..EI work as combined bearings, the basic dynamic load is defined as:

C_{wr} basic radial dynamic load, it is the radial load [N] that applied to the guide roller gives 100 km nominal life*.

C_{wa} basic axial dynamic load, it is the axial load [N] that applied to the guide roller gives 100 km nominal life*.

Note1*: ISO 281 states ‘the nominal life will be exceeded by 90% of bearings before the first sign of material fatigue’.

Nominal life calculation

System life is the minimum life of either the bearings in the guide roller or the rail/roller contact surfaces.

For the rail/roller surface see the lubrication paragraph. For the bearings life proceed as follows.

The loads P_r and P_a are calculated for ideal condition. However, in practice, because of the structure and operating conditions a better calculation and life estimation is performed using overload factor f_w as follows:

- 1.0 – 1.2 smooth operation at low speed at constant load without shocks
- 1.2 – 1.5 smooth operation with load variation
- 1.5 – 2.0 operation with small shocks and vibrations
- 2.0 ~ 4.0 high acceleration, shocks and vibrations

Once P_a and P_r has been defined we can proceed to calculate the equivalent load P_{eq} (not for FRN..EI).

$$P_{eq} = X P_r + Y P_a \quad [N]$$

Coefficients X and Y can be obtained from guide rollers tables (In case of tapered bearings accordingly with ratio between P_a and P_r).

In case of pure radial guide roller as PK and GC or floating bearings FRL, RAL.

$$P_{eq} = P_r \quad [N]$$

Nominal bearing life:

$$L_{10} = 100 \left(\frac{C_w}{P_{eq} \cdot f_w} \right)^p \quad [km]$$

Where coefficient P is:

P = 3 for ball bearing guide rollers (FR,FR..EI, RCL..., PFV..., RAL)

P = 10/3 for roller bearing guide rollers (PK...,RKY,RKX,ROLBLOC,GC,FRL..)

In case of guide rollers based on needle bearings type FRN..EI

nominal bearing life is calculated as the minimum between:

$$L_{10} = 100 \left(\frac{C_{wr}}{P_r \cdot f_w} \right)^{10/3} \quad [km]$$

and

$$L_{10} = 100 \left(\frac{C_{wa}}{P_a \cdot f_w} \right)^{10/3} \quad [km]$$

Checking the roller stud

The values of the radial limit loads F_r and axial limit loads F_a shown in the catalogue refer to extreme operating conditions, meaning:

$P_a = 0$ (pure radial load)

$P_r = P_a \tan \alpha$ (maximum axial load)

In intermediate cases, when the ratio is included between the extreme values, the equivalent limit load F_k to be considered must be calculated according to ratio $k = P_a/P_r$.

$$F_k = \frac{F_r \cdot F_a}{K \cdot F_r + (1 - K \tan \alpha) \cdot F_a} \quad [N]$$

To check the strength of the stud, in relation to the limit load, the safety factor has to be greater than 1

$$F_k/P_r > 1$$

Note: in the following common cases it is not necessary to calculate F_k and stud safety evaluation can be completed easily.

In case of floating bearings type FRL and guide rollers PK and GC there isn't any axial load. In case of loads acting in the guide roller plane (F_x or F_y

acting with $Z=0$) the axial load is also zero (0) (see calculation example n° 3).

In these cases it has to be

$$\text{Safety stud check} \quad F_r/P_r > 1$$

In case of load F_z acting perpendicular at guide roller plane the axial load is maximum (load case c, example n° 4).

$$\text{Safety stud check} \quad F_a/P_a > 1$$

Checking the bearing max load

In case of guide rollers based on tapered roller bearings (PK..C, RKU.., RKY.., RKX..) or ball bearings (FR..EI RCL.. PFV..)

We proceed as for the stud

ratio $k = P_a/P_r$.

$$C_{ok} = \frac{C_{or} C_{oa}}{K C_{or} + (1 - K \tan \alpha) C_{oa}} \quad [N]$$

To check the bearing static safety factor it has to be:

$$C_{ok}/P_r > 1$$

As explained for stud calculation in case of pure radial load or max axial load, calculations can be made using values directly from the tables (see calculation example 3 and 4).

In case of guide rollers based on needle bearings type FRN..EI

To check the bearing static safety factor it has to be:

$$C_{or}/P_r > 1$$

$$C_{oa}/P_a > 1$$

In case of guide rollers have two outer rings and ball bearings FR..,

To check the bearing static safety factor it has to be:

$$C_{or}/P_r > 1$$

$$C_{oa} / \left(\frac{P_a}{2} + \frac{P_r}{2 \tan \alpha} \right) > 1$$

Lubrication

Bearing lubrication

All guide rollers, with the exception of needle guide roller FRN..EI type, are equipped with long life lubricated bearings. Here, the bearings are provided with sufficient grease for the guide roller life.

Needle guide rollers bearings FRN..EI type, are designed to allow relubrication appropriate to load and cycle time. Contact Nadella Technical Department for support in relubrication interval.

Rail lubrication

Rails have to be lubricated. Lubrication reduces friction and allows a long system life and high speeds to be achieved.

No lubrication, or insufficient lubrication, is cause of fretting corrosion. Typical tribocorrosion sign is red oxide and rapid rail/rollers wearing.

Rail lubrication, clean or dirty environment and load all have to considered together to estimate system life. In case of load close to the limit load F_r and F_a and frequent duty cycle contact Nadella Technical Service.

Examples of calculation

1) A fork-lift truck featuring vertical movement (sketch 1).

The resulting magnitude of the weight passes through point 1, while the vertical force that balances this, for instance the traction of a timing belt, passes through point 2.

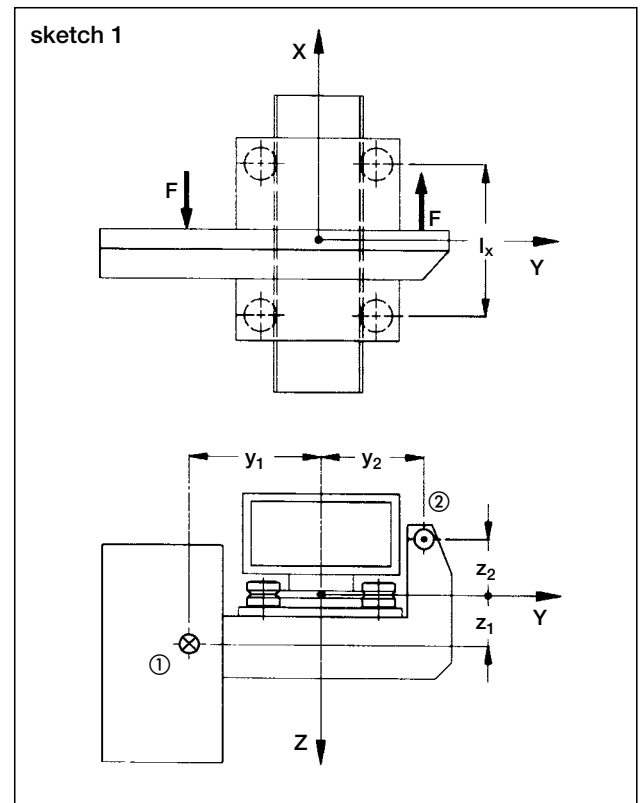

Guide rollers type RKY 52 are used with guide rail type FS 62 MT

overload factor $f_w = 1,0$
 center distance $l_x = 300 \text{ mm}$ $l_y = 144,3$
 $F = 2000 \text{ N}$ $z_1 = 100 \text{ mm}$ $y_1 = -150 \text{ mm}$
 $z_2 = -250 \text{ mm}$ $y_2 = 350 \text{ mm}$
 $\Delta_z = 350 \text{ mm}$ $\Delta_y = 500 \text{ mm}$

Load on rollers

$$P_a = \frac{2000 \cdot 350}{2 \cdot 300} = 1.167 \text{ N}$$

$$P_r = \frac{2000}{300} \cdot \left(\frac{350 \tan 40}{2} + 500 \right) = 4312 \text{ N}$$

Nominal life

$$k = P_a / P_r = 0.27 \rightarrow X = 0.77 \quad Y = 6.98$$

Equivalent dynamic load

$$P_{eq} = 0.77 \cdot 4312 + 6.98 \cdot 1.167 = 11464 \text{ N}$$

$$L_{10} = 100 \left(\frac{40800}{11464 \cdot 1} \right)^{10/3} = 6880 \text{ km}$$

Stud safety coefficient

Equivalent limit load F_k

$$F_k = \frac{11900 \cdot 4250}{0.27 \cdot 11900 + (1 - 0.27 \tan 40) \cdot 4250} = 7780 \text{ N}$$

Stud safety coefficient

$$F_k / P_r = 7780 / 4312 = 1.8$$

Bearing safety coefficient

Equivalent limit load C_{ok}

$$C_{ok} = \frac{44000 \cdot 12400}{0.27 \cdot 44000 + (1 - 0.27 \tan 40) \cdot 12400} = 25380 \text{ N}$$

Bearing static safety coefficient

$$C_{ok} / P_r = 25380 / 4312 = 5,9$$

2) The horizontal axis of a manipulator in steel industry

The centre of gravity of the vertical axis and load is placed in the middle of the horizontal centre-axis l_x and 160 mm distance from the guide axis.

The dirty environment and the possibility of shocks lead to the choice to ROLBLOC system.

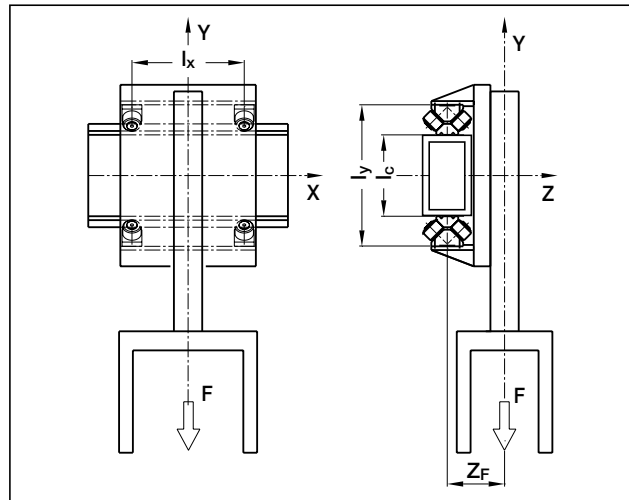

Guide rollers BL252 are used with guide GU62M

Overload factor $f_w = 1,4$

Centre distance $l_x = 350 \text{ mm}$ $l_y = 400 \text{ mm}$
 $F = 6000 \text{ N}$ $x = 0$ $y = -1000$ $z = 160 \text{ mm}$

Load on rollers

The effective centeraxis l_c is $400 - 85 - 85 = 230 \text{ mm}$

$$P_a = \frac{6000 \cdot 160}{2 \cdot 230} = 2087 \text{ N}$$

$$P_r = \frac{6000 \cdot (350+0)}{2 \cdot 350} + \frac{6000 \cdot 160 \tan 45}{2 \cdot 230} = 5087 \text{ N}$$

Nominal life

From the ROLBLOC table $X=1, Y=1$

$$P_{eq} = 1 \cdot 2087 + 1 \cdot 5087 = 7174 \text{ N}$$

$$L_{10} = 100 \left(\frac{59000}{7174 \cdot 1.4} \right)^{10/3} = 36577 \text{ km}$$

Stud safety coefficient

$$K = P_a / P_r = 2087 / 5087 = 0,41$$

$$F_k = \frac{16800 \cdot 8400}{0.41 \cdot 16800 + (1 - 0.41 \tan 45) \cdot 8400} = 11915 \text{ N}$$

$$F_k / P_r = 11915 / 5087 = 2.3$$

Bearing safety coefficient

$$C_{ok} = \frac{62000 \cdot 31000}{0.41 \cdot 62000 + (1 - 0.41 \tan 45) \cdot 31000} = 43972 \text{ N}$$

$$F_k / P_r = 43972 / 5087 = 8.6$$

3) The sliding door of a machine tool (rail on top)

The door is supported by the rail DC type on the upper edge and driven on bottom side by an auto-aligning carriage C3RAL on LM guide rail type. Because of the effect of the bottom rail there isn't any torque applied at the DC rail. The door weight acts in a plane coincident with the roller/rail vertical axis and as such there is no over turning moment. In this case, limit load calculation can be easily carried out from basic data F_a and C_{oa} without F_k and C_{ok} calculation. Of course the calculation is always the same.

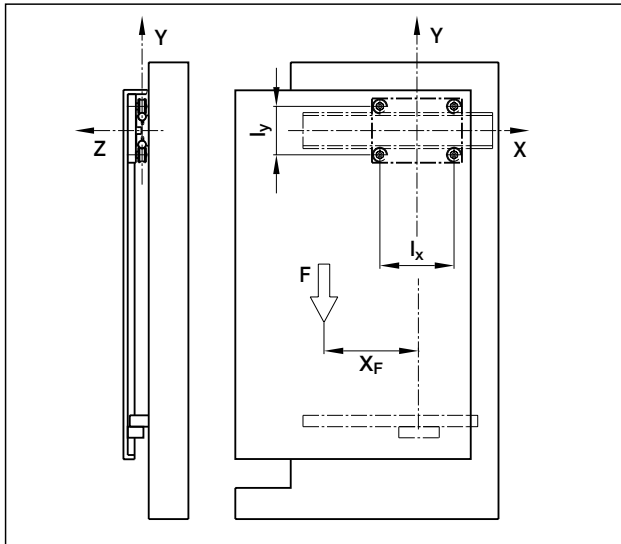

Guide rail DC18.65 is used with carriage T4 PFV 3518 250
 Overload factor $f_w = 1,1$
 Centre distance $l_x = 213 \text{ mm}$ $l_y = 113 \text{ mm}$
 $F=450 \text{ N}$ $x=300$ $y=-500$ $z = 0$
 (because of LM rail) mm

Load on rollers

The effective centeraxis l_c is $113 - 35 = 78 \text{ mm}$

$$P_a = \frac{450 \cdot 0}{2 \cdot 78} = 0 \text{ N}$$

$$P_r = \frac{450 \cdot (213 + 2 \cdot 300)}{2 \cdot 213} + \frac{450 \cdot 0 \cdot \tan(40)}{2 \cdot 213} = 859 \text{ N}$$

Nominal life

$$L_{10} = 100 \left(\frac{4570}{859 \cdot 1,1} \right)^3 = 11300 \text{ km}$$

Stud safety coefficient

$$F_r/P_r = 2120 / 859 = 2,4$$

Bearing safety coefficient

$$C_{or}/P_r = 2320 / 859 = 2,7$$

4) Transfer unit

The box weight loads the carriage with max axial load. In this load configuration the safety stud check calculation can be easily done directly by the F_a and C_{oa} value without F_k calculation.

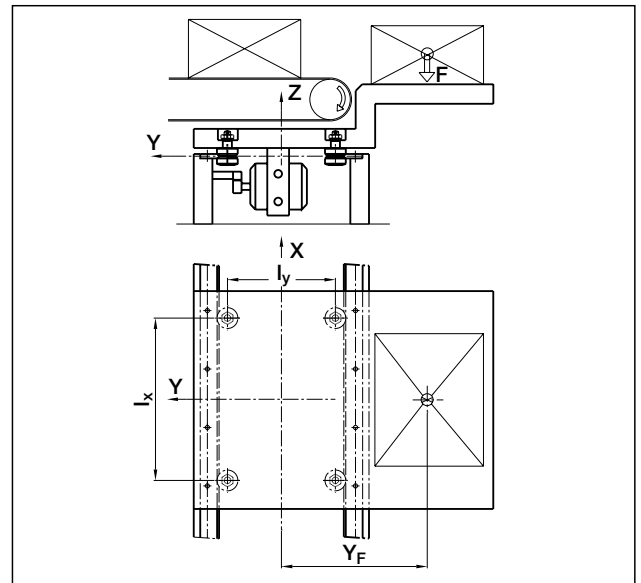

Guide rollers FRN(R)32EI with rails FSH32M
 Overload factor $f_w = 1,2$
 Centre distance $l_x = 670 \text{ mm}$ $l_y = 450 \text{ mm}$
 $F=400 \text{ N}$ $x=0$ $y=650$ $z = 50 \text{ mm}$

Load on rollers

The effective centeraxis l_c is $450 + 32 = 482 \text{ mm}$

$$P_a = \frac{400}{4} + \frac{400 \cdot 650}{2 \cdot 482} = 370 \text{ N}$$

$$P_r = 370 \tan 40 = 310 \text{ N}$$

Nominal life

$$L_{10r} = 100 \left(\frac{5600}{310 \cdot 1,2} \right)^{10/3} = 840000 \text{ km}$$

$$L_{10a} = 100 \left(\frac{2100}{370 \cdot 1,2} \right)^{10/3} = 17760 \text{ km}$$

$$L_{10} = 17760 \text{ km}$$

Stud safety coefficient

$$F_a/P_a = 950 / 370 = 2.5$$

Bearing safety coefficient

$$C_{or}/P_r = 5100 / 370 = 13,7$$

For further details, contact the NADELLA Technical Service.

GU System

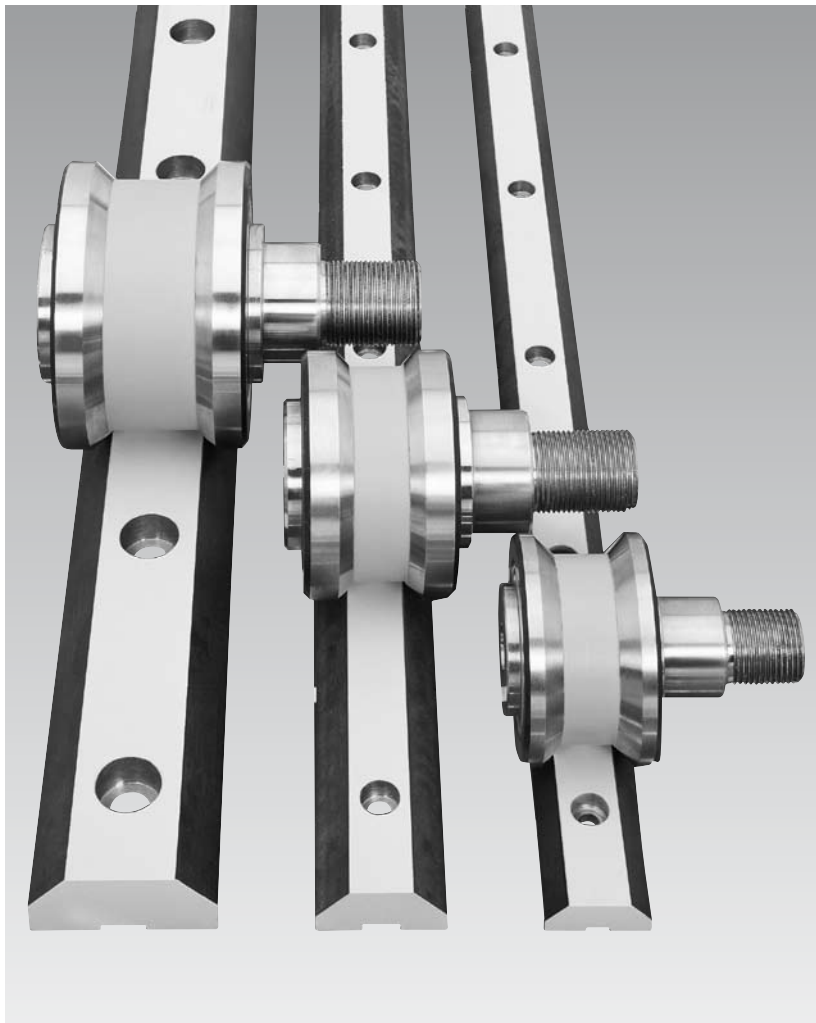

NADELLA

Guide Rails GU..M - GU..MT

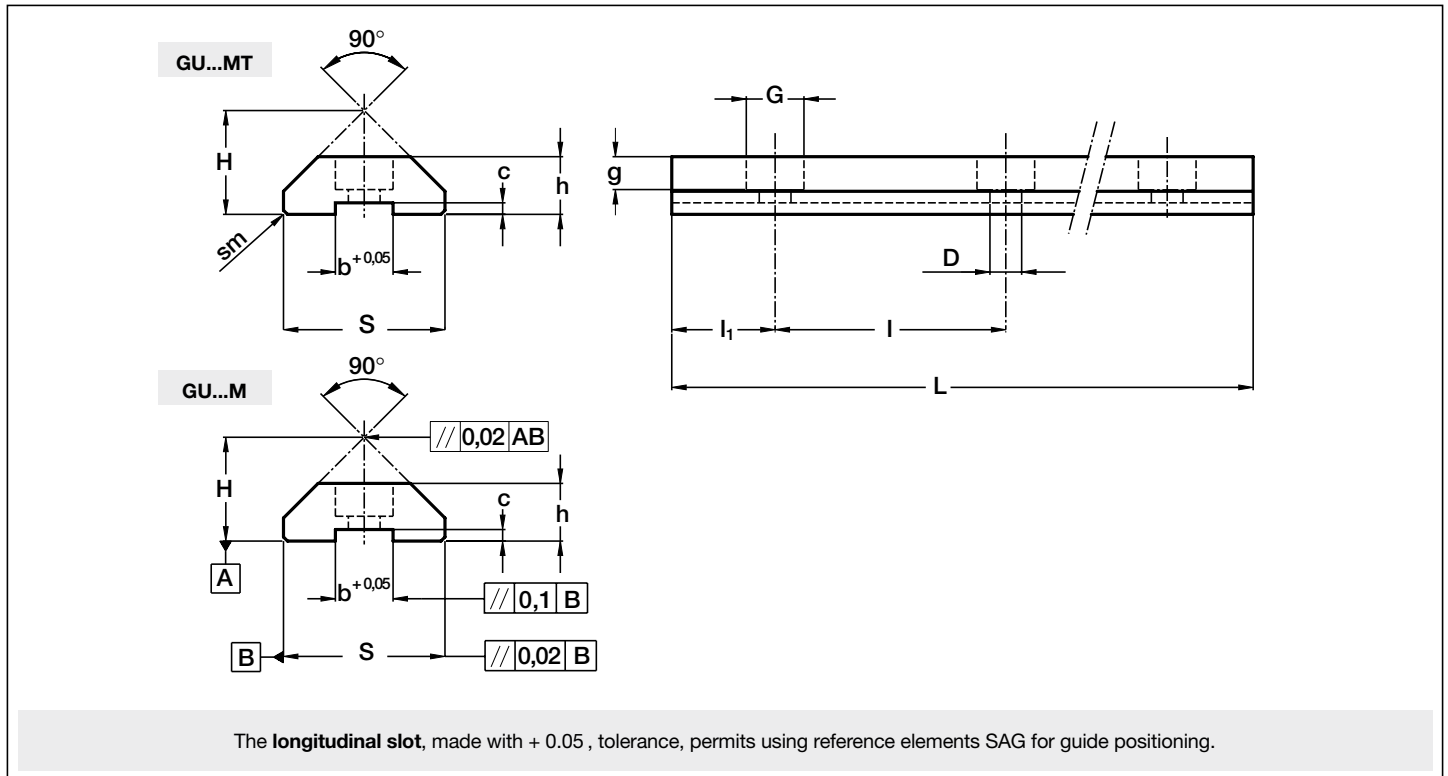

Type	Dimensions (mm)											Weight (kg/m) ⁽²⁾
	H ± 0.05	h ± 0.05	S ± 0.05	D + 0.1	G	g	b + 0.05	c ± 0.05	sm	I	I ₁	
GU 28 MT	19	11	28.8	5.5	10	5.7	10	2.5	0.7x45°	90	30	1.97
GU 35 MT	23.9	15.7	35.5	6.6	11	6.8	10	3.8	1x45°	90	30	3.35
GU 50 MT	35.5	21	50.8	11	18	11	16	4.3	1x45°	90	30	6.89

max length in single element L=6 000 mm (1)

Type	Dimensions (mm)											Weight (kg/m) ⁽²⁾
	H ± 0.05	h ± 0.05	S ± 0.05	D + 0.1	G	g	b + 0.05	c ± 0.05	I	I ₁		
GU 28 M	18	10	28	5.5	10	5.7	10	2	90	30	1.8	
GU 35 M	23	15	35	6.6	11	6.8	10	3.3	90	30	3.2	
GU 50 M	34.5	20	50	11	18	11	16	3.8	90	30	6.8	

max length in single element L=4 020 mm (1)

(1) longer rails are supplied in sections with ground butt joints - (2) Weight without holes

Rails finishing

- drawn, induction hardened and sandblasted tracks (**MT**);
- drawn, induction hardened and ground (**M**)
- Induction hardening on raceways only

Hole layout

- holes according to catalogue (**SB**)
- finishes to drawing (**NZ**)
- without holes (**NF**)

Optional features

- ground one end (**R**)
- ground both ends (**RR**)
- chemical Nickel-plating (**NW**)

Example of standard designation: **GU 35 MT/4300/SB**

See page 9 for standard codification

Guide Rollers **RKU**

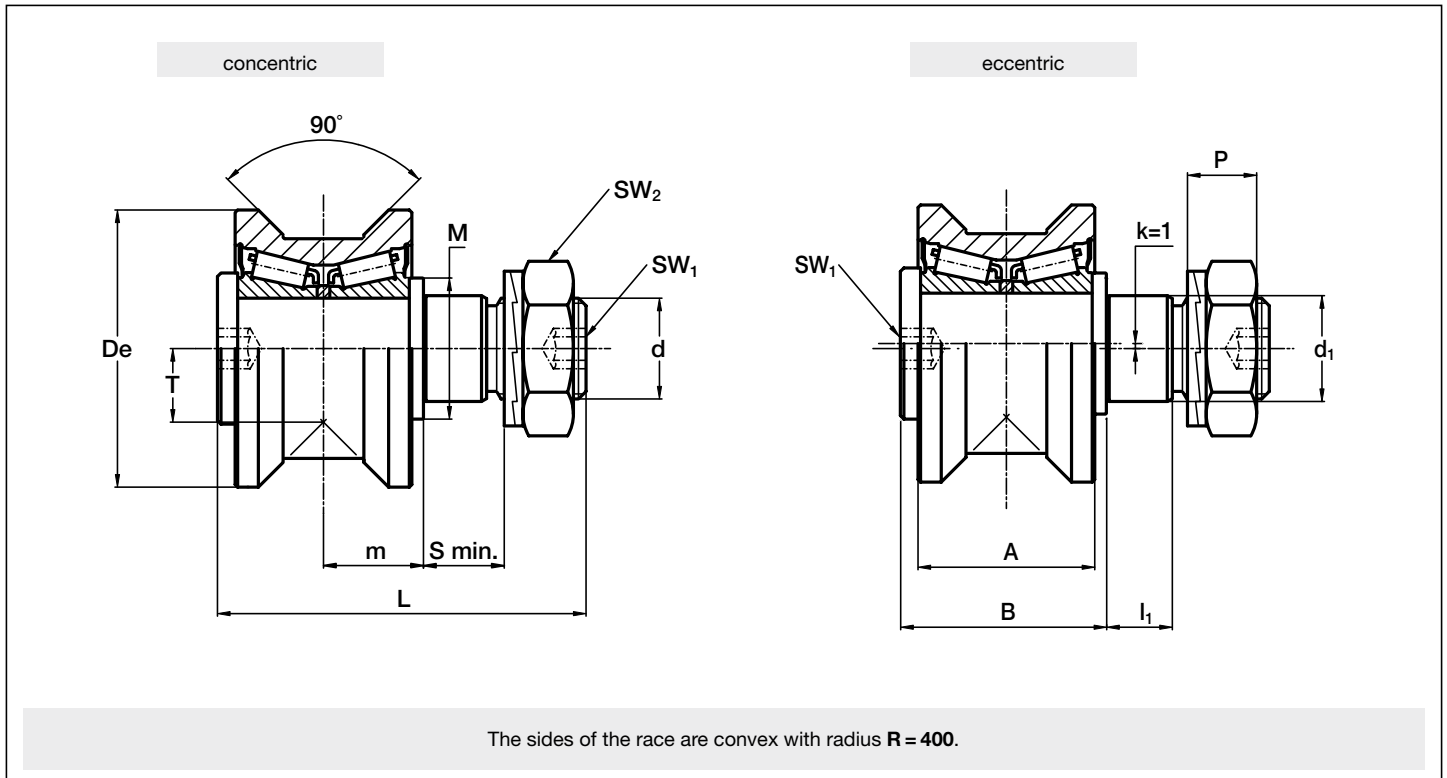

Type		Dimensions (mm)														
concentric	eccentric	De	d ₁ ⁽¹⁾	d	T	m	S min.	P	L	A	B	l ₁	M	SW ₁	SW ₂	k
RKU 55	RKUR 55	55	21	M 20 x 1.5	14.6	19.8	15	13.4	73	35	41	14	28	8	ch. 30	1
RKU 65	RKUR 65	65	27	M 24 x 1.5	18	20.8	19	15.4	83	37	44	18	35	10	ch. 36	1
RKU 75	RKUR 75	75	36	M 30 x 1.5	23.7	27	19	21.6	100	45	55	18	44	12	ch. 46	1
RKU 95	RKUR 95	95	38	M 36 x 1.5	25.5	30	24	24.6	115	53	62	23	50	14	ch. 55	1
RKU 115	RKUR 115	115	42	M 36 x 1.5	33.5	34	33	24.6	135	53	70	32	56	14	ch. 55	1

Type		Bearing rating (N)			Limit loads (N)		Life coefficients				Torque wrench settings ⁽²⁾ (Nm)	Weight (kg)
		Dynamic	Static				P _a /P _r ≤ 0.1		P _a /P _r > 0.1			
			C _w ⁽⁶⁾	radial C _{or}	axial C _{oa}	radial F _r	axial F _a	X	Y	X		
RKU 55	RKUR 55	41 650	44 000	12 400	11 900	4 250	1	4.67	0.77	6.98	80	0.6
RKU 65	RKUR 65	46 800	50 400	12 750	22 100	6 800	1	3.93	0.74	6.55	160	0.9
RKU 75	RKUR 75	66 700	72 000	18 900	31 300	10 100	1	4.67	0.77	6.98	300	1.6
RKU 95	RKUR 95	116 800	136 000	37 800	43 700	12 600	1	3	0.8	4.96	450	2.8
RKU 115	RKUR 115	182 450	195 000	50 000	55 600	17 900	1	4.26	0.72	7.1	450	4.9

- Housing bore tolerance: H7
- The torque wrench settings are given for non-lubricated threads; for lubricated threads, multiply figure by 0.8
- Standard seals: material NBR, RS type
- On request, the guide rollers can be supplied in AISI 440 stainless steel (suffix **NX**) and with Viton seals for operating temperatures up to 120 °C (suffix **V**)
- Dimensions relating to the stainless-steel rollers (suffix **NX**)
- C_w basic load for 100 km
- The guide rollers include self-locking washers and hexagonal nut (DIN 439B) for fitting
- Pressure angle α for load calculation: 45°

Guide wheels **FKU**

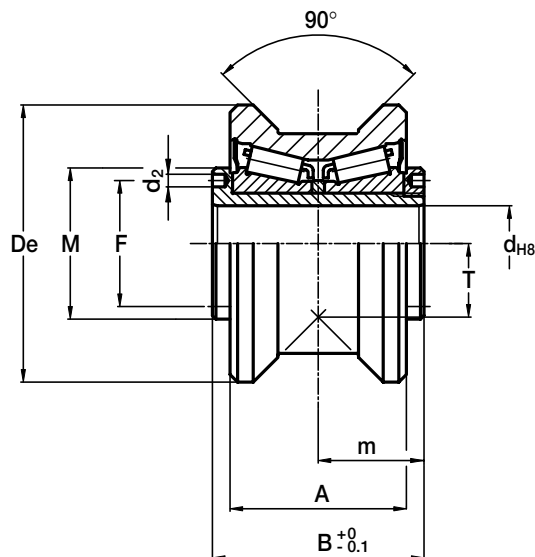

The sides of the race are convex with radius $R = 400$.

Type	Dimensions (mm)								
	De	d	t	m	A	B	F	d ₂	M
FKU 55	55	15	14.6	21	35	42	25	2.5	30
FKU 65	65	20	18	22.5	37	45	29	3	35
FKU 75	75	25	23.7	28	45	56	37	4	44
FKU 95	95	28	25.5	32	53	56 ⁽²⁾	42	4	49
FKU 115	115	35	33.5	36	60	63 ⁽²⁾	52	4	59

Type	Bearing rating (N)			Life coefficients				Weight (kg)
	Dynamic C _w ⁽³⁾	Static		P _a /P _r ≤ 0.1		P _a /P _r > 0.1		
		radial C _{or}	axial C _{oa}	X	Y	X	Y	
FKU 55	41 650	44 000	12 400	1	4.67	0.77	6.98	0.5
FKU 65	46 800	50 400	12 750	1	3.93	0.74	6.55	0.6
FKU 75	66 700	72 000	18 900	1	4.67	0.77	6.98	1.2
FKU 95	116 800	136 000	37 800	1	3	0.8	4.96	2.3
FKU 115	182 450	195 000	50 000	1	4.26	0.72	7.1	3.9

- 1) On request, the guide rollers can be supplied in AISI 440 stainless steel (suffix **NX**) and with Viton seals for operating temperatures up to 120 °C (suffix **V**)
- 2) Dimensions relating to the stainless-steel rollers (suffix **NX**)
- 3) C_w basic load for 100 km
- 4) To prevent rotation between roller and shaft a pin can be fitted in one of the holes "d₂" positioned in the side flange
- 5) Pressure angle α for load calculation: 45°
- 6) Standard seals: material NBR, RS type

Guide pins SAG

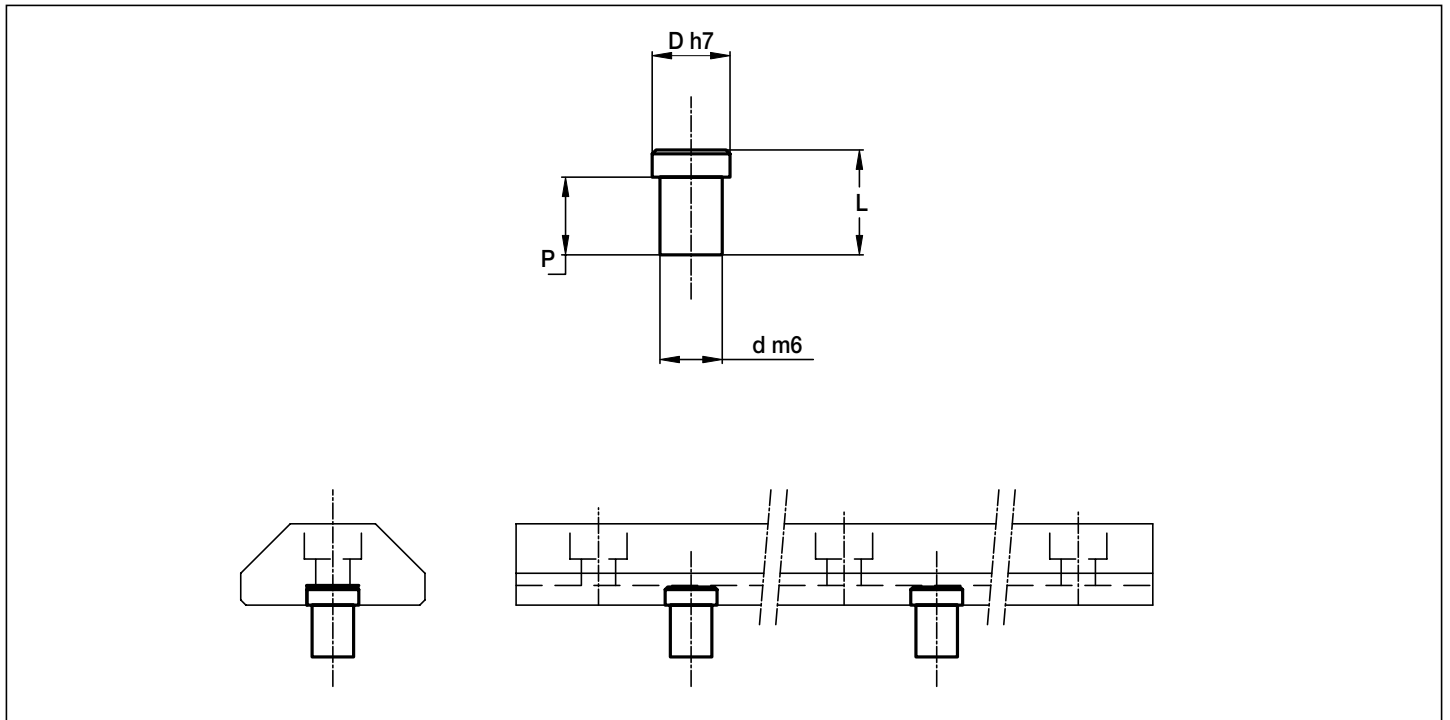
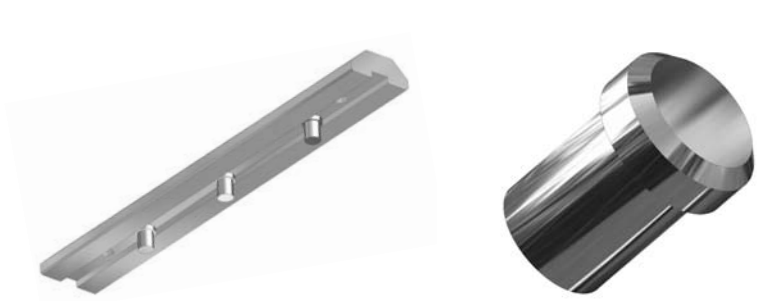

Pin type	Guide type	Dimensions (mm)			
		D	d ⁽¹⁾	P	L
SAG 28	GU 28 MT	10	8	10.0	12.3
SAG 35	GU 35 MT	10	8	10.0	13.5
SAG 50	GU 50 MT	16	10	11.2	15.0

1) Housing bore tolerance: H7

Guide roller combinations

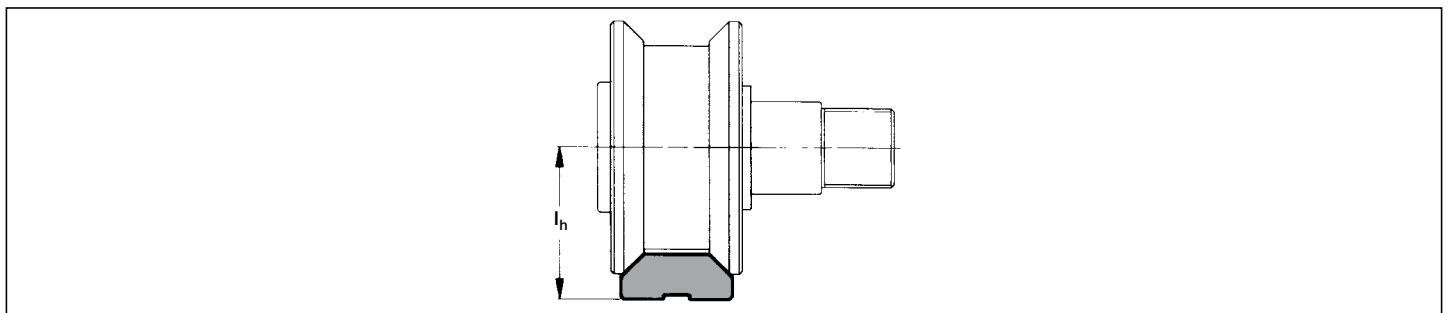

Guide \ Roller	l_h (mm)				
	RKU 55	RKU 65	RKU 75	RKU 95	RKU 115
GU 28 MT	33.6	37	–	–	–
GU 28 M	32.6	36	–	–	–
GU 35 MT	–	41.9	47.6	–	–
GU 35 M	–	41	46.7	–	–
GU 50 MT	–	–	–	61	69
GU 50 M	–	–	–	60	68

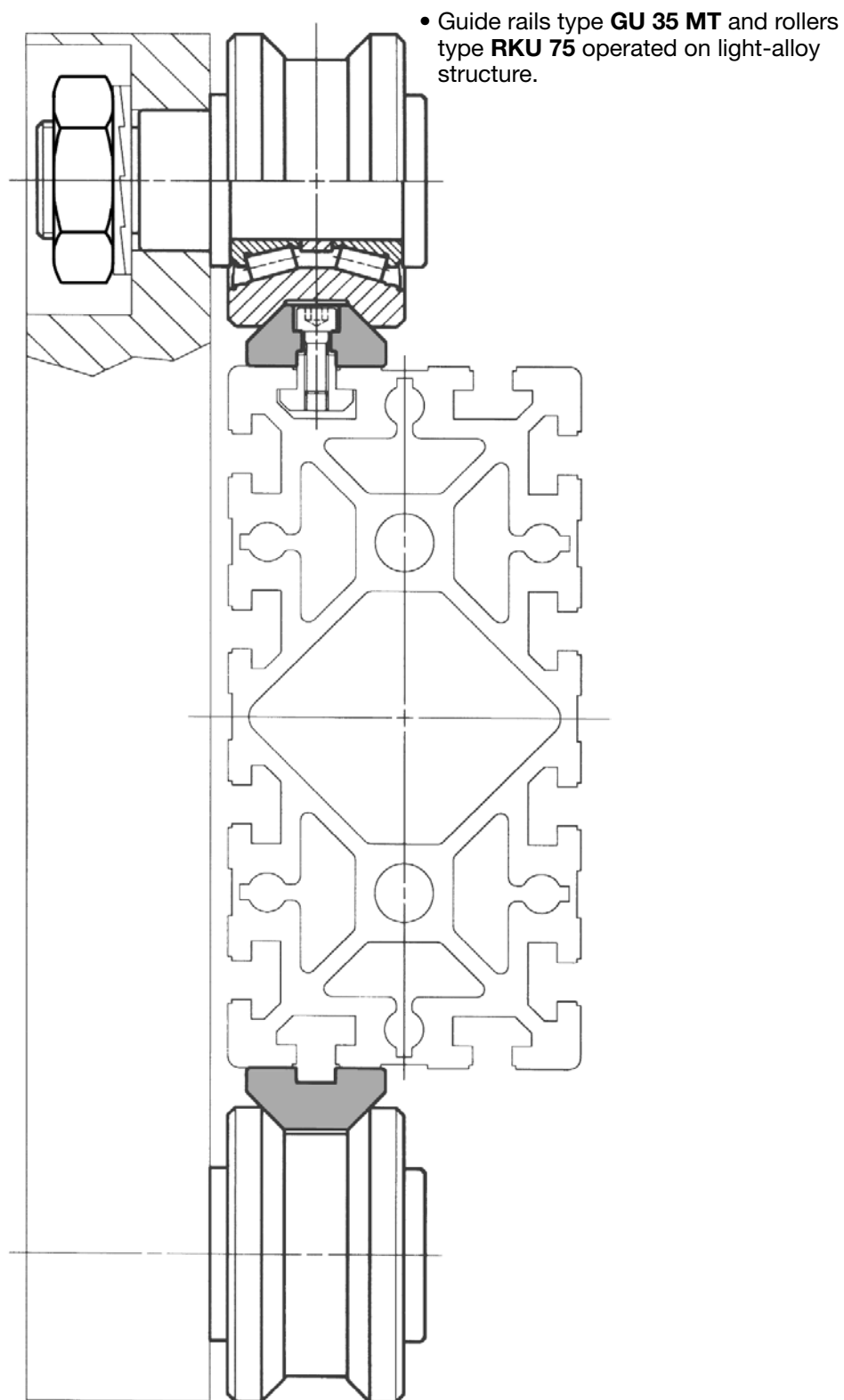

ROLBLOC System



NADELLA

Guide Rails **GU..M - GU..MT**

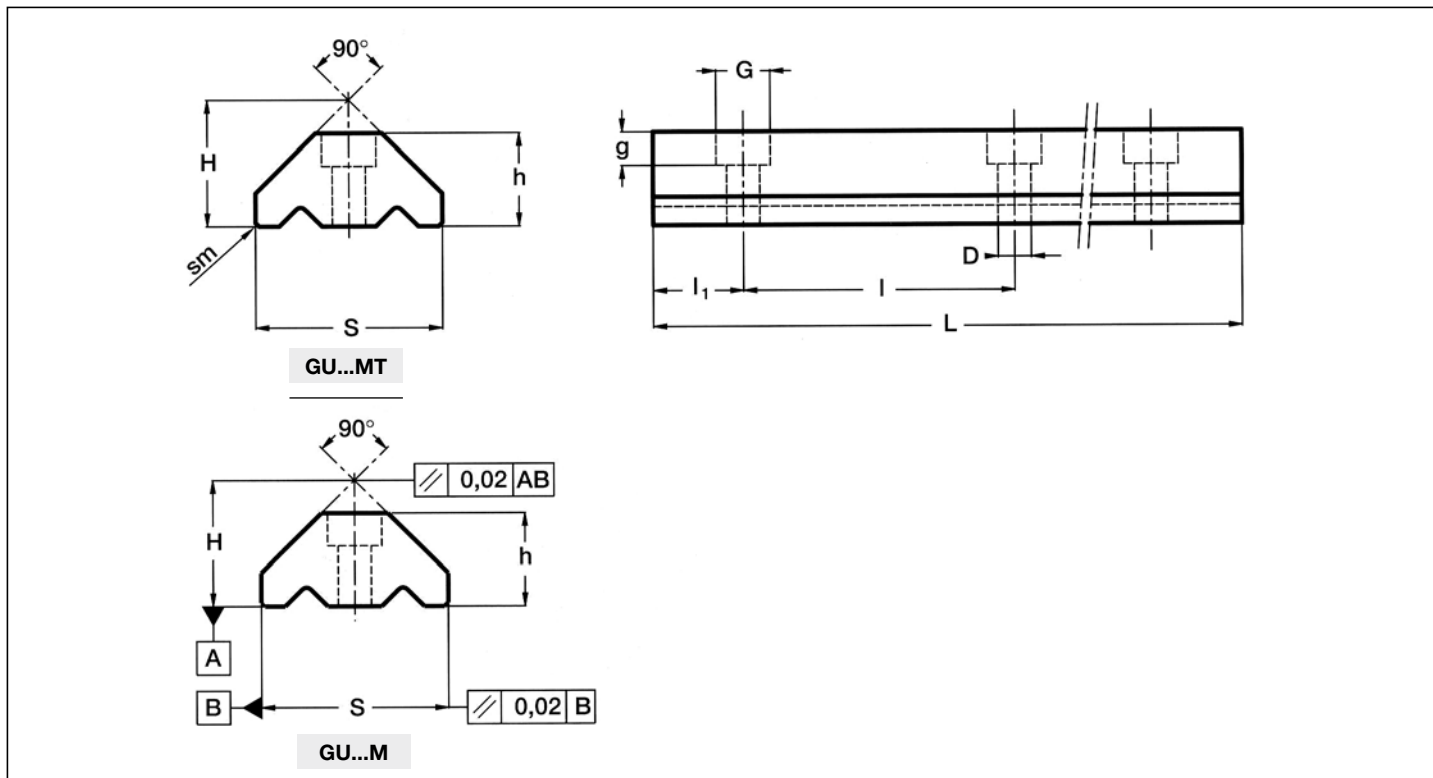

Type	Dimensions (mm)									Weight (kg/m) ⁽²⁾
	H ± 0.05	h ± 0.05	S ± 0.05	D + 0.1	G	g	sm	l	l ₁	
GU 62 MT	43.5	32.5	63.5	11	18	11	2x45°	120	30	11.8
GU 80 MT	56.7	41.5	81.5	13.5	20	13	2x45°	120	30	20.3

max length in single element L = 6 000 mm (1)

Type	Dimensions (mm)									Weight (kg/m) ⁽²⁾
	H ± 0.05	h ± 0.05	S ± 0.05	D + 0.1	G	g	l	l ₁		
GU 62 M	42	31	62	11	18	11	120	30	10.9	
GU 80 M	55.2	40	80	13.5	20	13	120	30	20	

max length in single element L = 4 020 mm (1)

(1) longer rails are supplied in sections with ground butt joints - (2) Weight without holes

Rails finishing

- drawn, induction hardened and sandblasted tracks (**MT**);
- drawn, induction hardened and ground (**M**)
- Induction hardening on raceways only

Hole layout

- holes according to catalogue (**SB**)
- finishes to drawing (**NZ**)
- without holes (**NF**)

Optional features

- ground one end (**R**)
- ground both ends (**RR**)
- chemical Nickel-plating (**NW**)

Example of standard designation: **GU 62 MT/4300/SB**

See page 9 for standard codification

Guide Rollers **ROLBLOC**

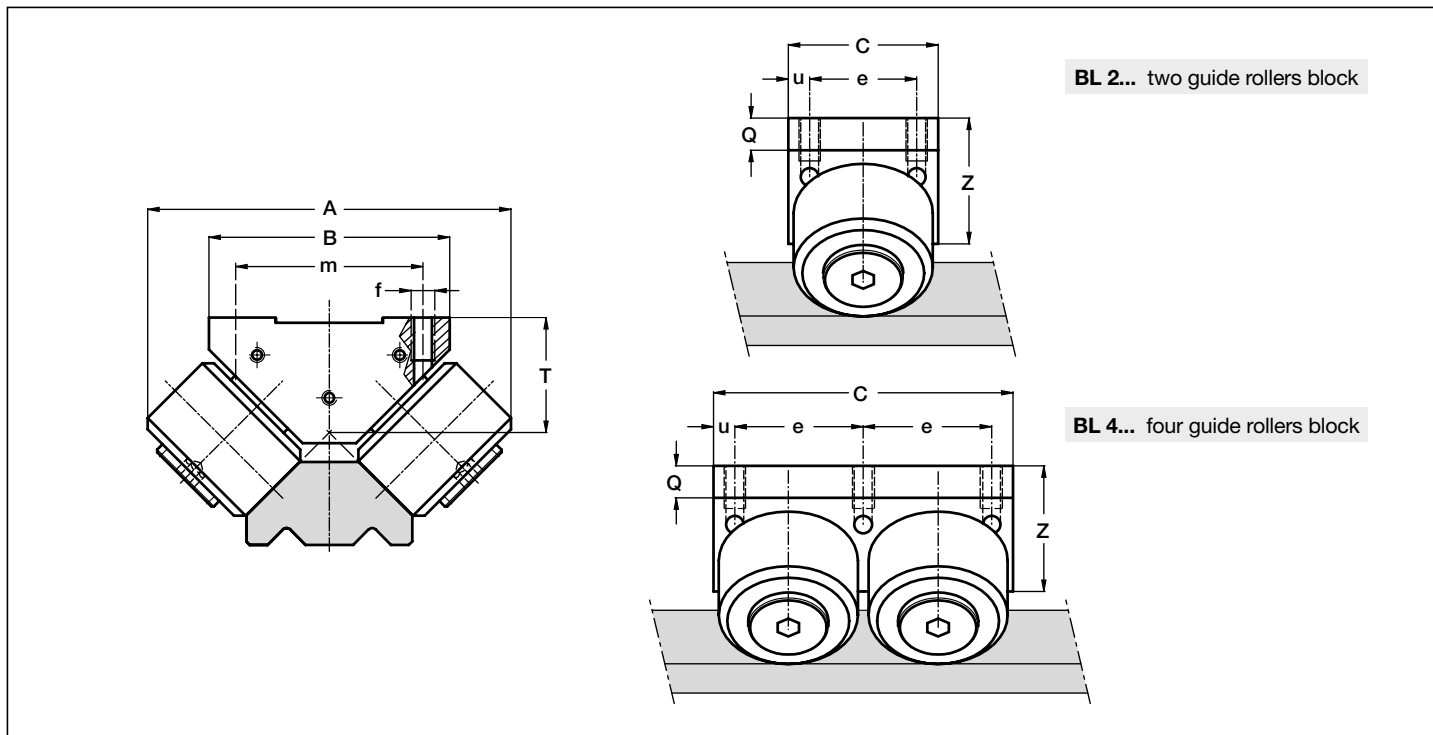

Type	Dimensions (mm)										Weight (kg)
	A	B	C	m	e	u	f	Q	T	Z	
BL 2 52	136	90	56	70	40	8	M 8	12	43	47	2.4
BL 4 52	136	90	112	70	48	8	M 8	12	43	47	4.8
BL 2 75	170	125	76	85	56	10	M 12	17.1	71.5	70	6.5
BL 4 75	170	125	152	85	66	10	M 12	17.1	71.5	70	13
BL 2 115	243	170	125	120	95	15	M 14	22	99.8	93	21.6
BL 4 115	243	170	250	120	110	15	M 14	22	99.8	93	43.2

Type	Bearing rating (N)			Limit loads (N)		Life coefficients	
	Dynamic $C_w^{(3)}$	Static		Radial $F_r^{(4)}$	Axial $F_a^{(5)}$	X	Y
		radial $C_{or}^{(4)}$	axial $C_{oa}^{(5)}$				
BL 2 52	59 000	62 200	31 100	16 800	8 400	1	1
BL 4 52	118 000	124 400	62 200	33 600	16 800	1	1
BL 2 75	96 300	101 800	50 900	44 200	22 100	1	1
BL 4 75	192 600	203 600	101 800	88 400	44 200	1	1
BL 2 115	264 500	276 000	138 000	78 600	39 300	1	1
BL 4 115	529 000	552 000	276 000	157 200	78 600	1	1

- 1) Standard seals: material NBR, RS type
- 2) On request, the guide rollers can be supplied with Viton seals for operating temperatures up to 120 °C (suffix **V**)
- 3) C_w basic load for 100 km, load perpendicular to the roller side fixing surface
- 4) Load perpendicular to the roller side fixing surface
- 5) Load parallel to the roller side fixing surface
- 6) Pressure angle α for load calculation: 45°

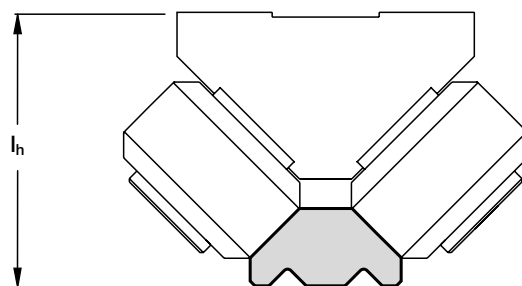

Guide \ Roller	l_h (mm)					
	BL 2 52	BL 4 52	BL 2 75	BL 4 75	BL 2 115	BL 4 115
GU 62 MT	86.5	86.5	115	115	-	-
GU 62 M	85	85	113.5	113.5	-	-
GU 80 MT	-	-	-	-	156.5	156.5
GU 80 M	-	-	-	-	155	155

Mounting Example

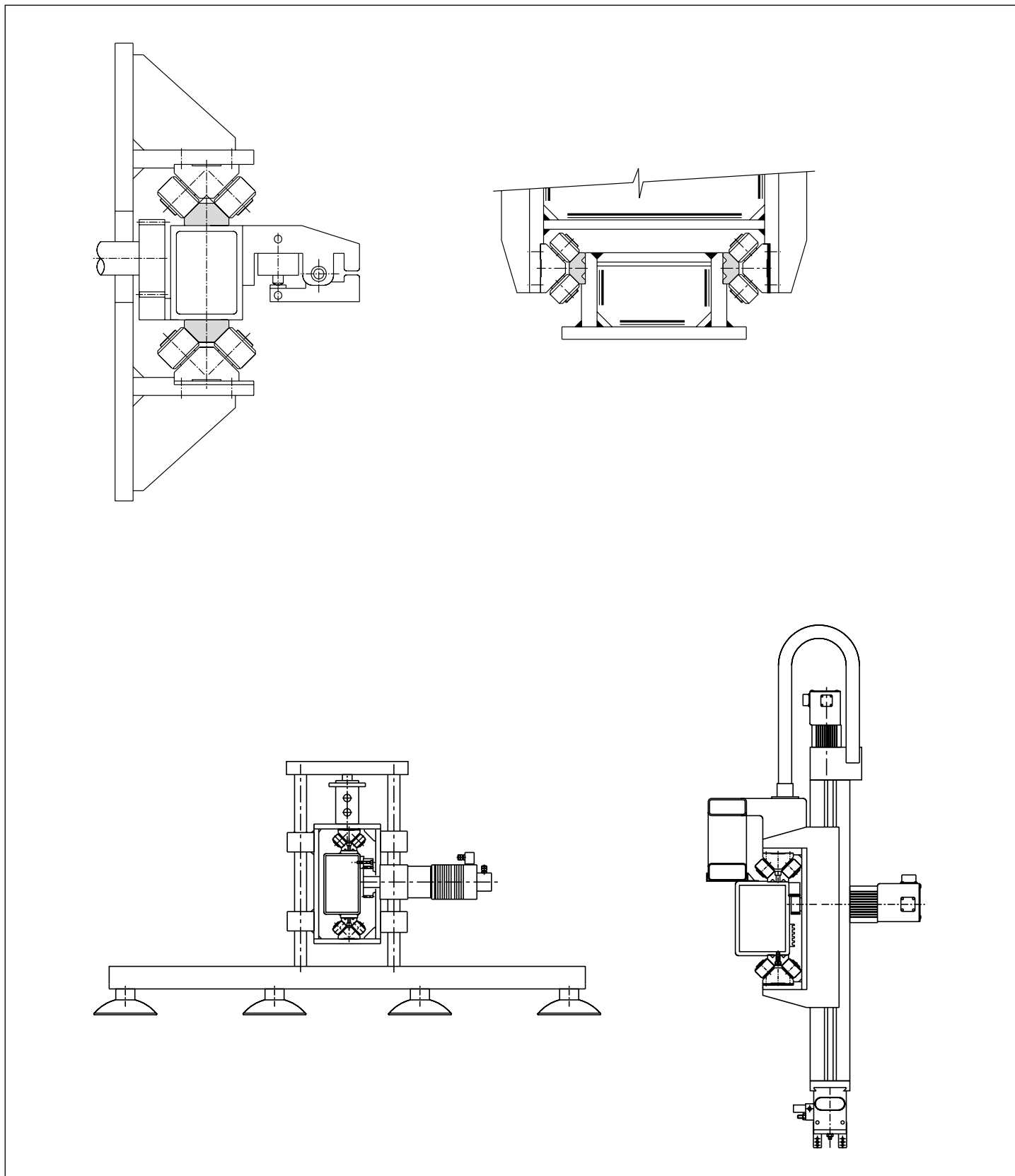

For further details, contact the NADELLA Technical Service.

FS System

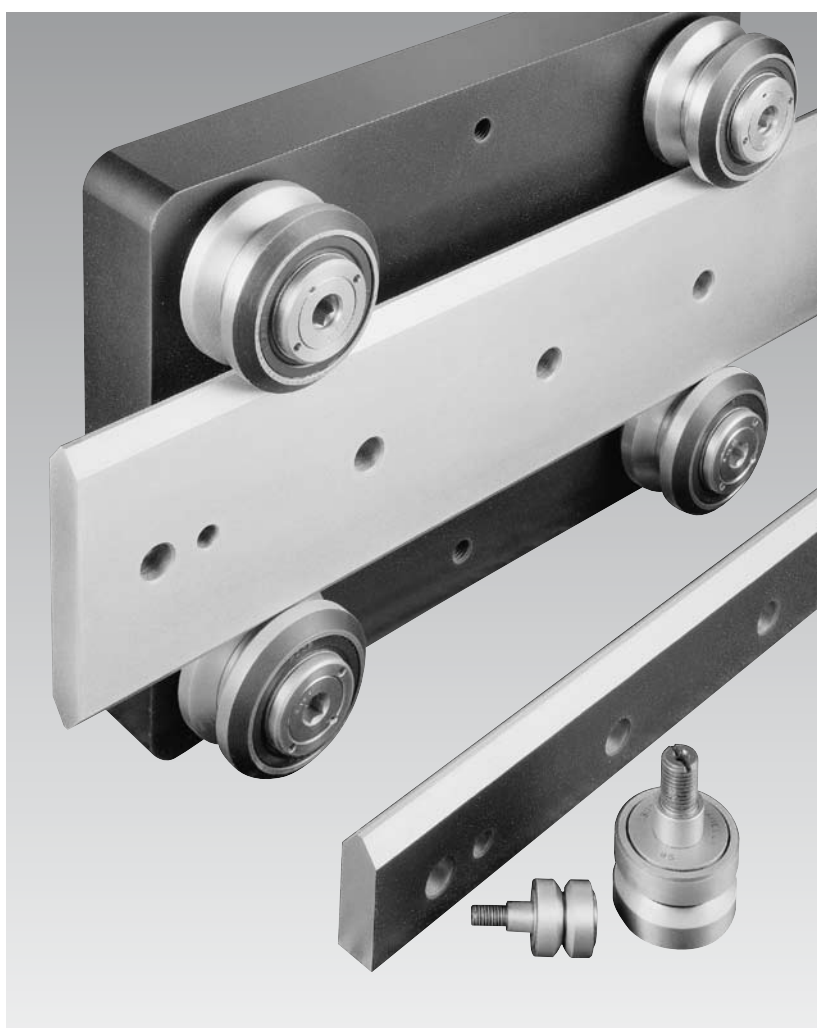

NADELLA

Guide Rails FS..MT

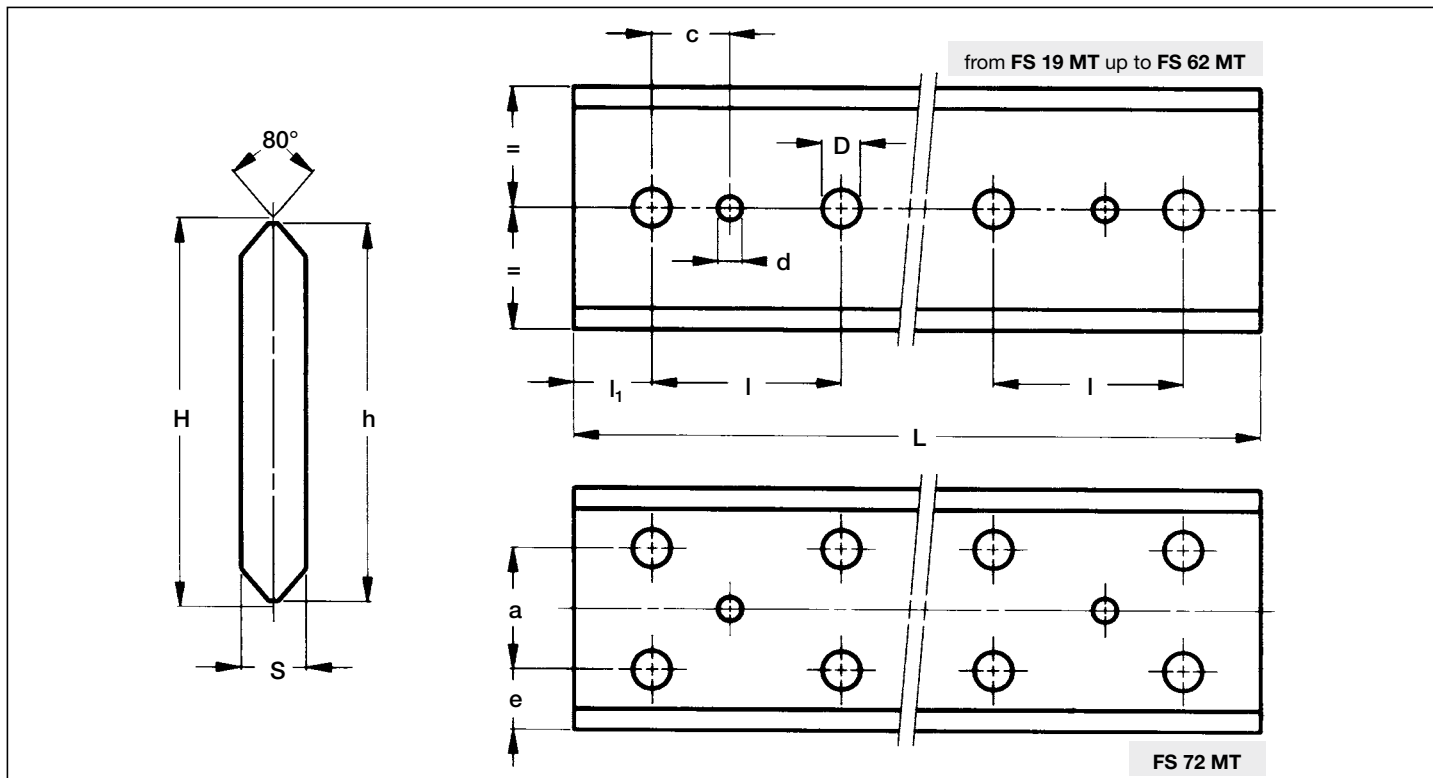

Type	Dimensions (mm)										Weight ⁽³⁾ (kg/m)
	H ± 0.1	h ± 0.1	S ± 0.1	d ⁽²⁾ + 0.05	D	c ⁽²⁾	e	a	l	l ₁	
FS 19 MT	22.20	21.0	5.3	4	6.5	15	–	–	90	30	0.8
FS 22 MT	28.80	27.0	5.8	5	6.5	15	–	–	90	30	1.1
FS 32 MT	43.80	42.0	6.8	6	6.5	15	–	–	90	30	2.1
FS 35 MT	48.80	47.0	8.8	6	9.0	20	–	–	90	30	3.0
FS 40 MT	64.50	62.0	8.8	6	9.0	20	–	–	90	30	4.1
FS 47 MT	80.15	77.2	11.0	6	11.5	20	–	–	90	30	6.3
FS 52 MT	91.35	88.2	13.0	8	13.5	20	–	–	90	30	8.5
FS 62 MT	106.00	103.0	15.7	8	13.5	20	–	–	90	30	11.7
FS 72 MT	124.60	121.0	19.0	10	17.5	30	30.5	60	90	30	16.9

Maximum length of single guide element L = 6 000 mm (1)

1) Longer rails are supplied in sections with ground butt joints

2) Dowel holes = standard Italian market; without pin holes = standard German market

3) Weight without holes

Rails finishing

- drawn, induction hardened and sandblasted tracks (**MT**);
- Induction hardening on raceways only

Hole layout

- holes according to catalogue (**SB**)
- finishes to drawing (**NZ**)
- without holes (**NF**)

Optional features

- ground one end (**R**)
- ground both ends (**RR**)
- chemical Nickel-plating (**NW**)

Example of standard designation: **FS 52 MT/5280/SB**

See page 9 for standard codification

Guide Rails FS..M

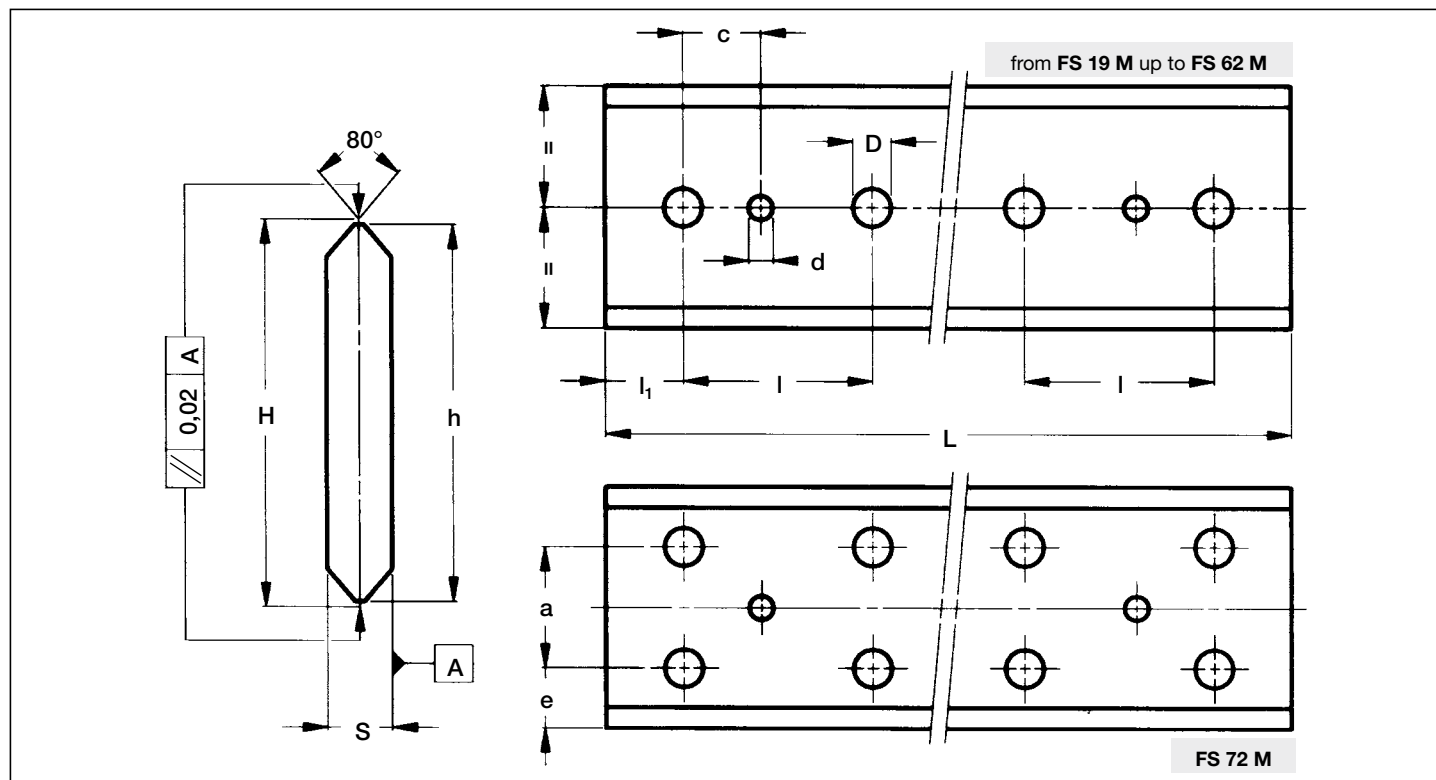

Type	Dimensions (mm)										Weight ⁽²⁾ (kg/m)
	H ± 0.05	h ± 0.1	S ± 0.05	d + 0.05	D	c	e	a	l	l ₁	
FS 19 M	20.95	20	4.5	4	6.5	15	-	-	90	30	0.6
FS 22 M	27.86	26	5.0	5	6.5	15	-	-	90	30	0.9
FS 32 M	42.86	41	6.0	6	6.5	15	-	-	90	30	1.8
FS 35 M	47.86	46	8.0	6	9.0	20	-	-	90	30	2.6
FS 40 M	63.58	61	8.0	6	9.0	20	-	-	90	30	3.7
FS 47 M	78.58	76	10.0	6	11.5	20	-	-	90	30	5.6
FS 52 M	89.78	87	12.0	8	13.5	20	-	-	90	30	7.7
FS 62 M	104.76	102	15.0	8	13.5	20	-	-	90	30	11.2
FS 72 M	122.98	120	18.0	10	17.5	30	30	60	90	30	15.8

Maximum length of single guide element L = 4,020 mm (1)

1) Longer rails are supplied in sections with ground butt joints

2) Weight without holes

Rails finishing

- drawn, induction hardened and ground profile (**M**);
- Induction hardening on raceways only

Hole layout

- holes according to catalogue (**SB**)
- finishes to drawing (**NZ**)
- without holes (**NF**)

Optional features

- ground one end (**R**)
- ground both ends (**RR**)
- chemical Nickel-plating (**NW**)

Example of standard designation: **FS 40 M/2760/SB**

See page 9 for standard codification

Guide Rails **FSH..MT, FSX..MT**

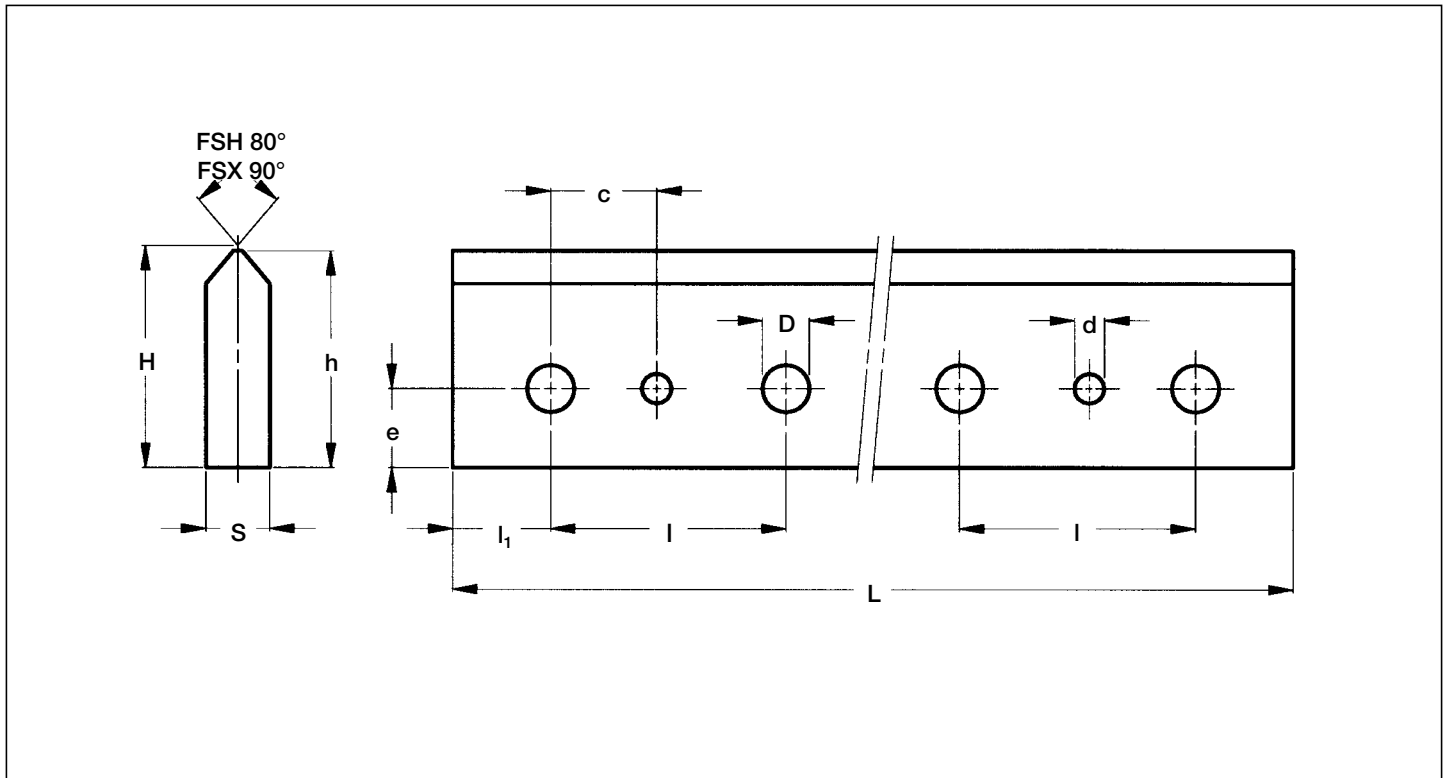

Type	Dimensions (mm)									Weight ⁽³⁾ (kg/m)
	H ± 0.1	h ± 0.1	S ± 0.1	d ⁽²⁾ + 0.05	D	c ⁽²⁾	e	l	l ₁	
FSH 22 MT	23.90	23.0	5.8	5	6.5	15	9	90	30	1.0
FSH 32 MT	29.90	29.0	6.8	6	6.5	15	11	90	30	1.5
FSH 40 MT	37.20	36.0	8.8	6	9.0	20	16	90	30	2.4
FSH 52 MT	40.75	39.2	13.0	8	13.5	20	17	90	30	3.7
FSH 62 MT	50.75	49.2	16.0	8	13.5	20	17	90	30	5.7
FSH 72 MT	60.85	59.2	19.0	10	17.5	30	20	90	30	8.2
FSX 90 MT	62.85	61.0	26.5	10	13.5	30	22	90	30	11.6

Maximum length of single guide element L = 6 000 mm⁽¹⁾

1) Longer rails are supplied in sections with ground butt joints

2) Dowel holes = standard Italian market; without pin holes = standard German market

3) Weight without holes

Rails finishing

- drawn, induction hardened and sandblasted tracks (**MT**);
- Induction hardening on raceways and base only

Hole layout

- holes according to catalogue (**SB**)
- finishes to drawing (**NZ**)
- without holes (**NF**)

Optional features

- ground one end (**R**)
- ground both ends (**RR**)
- chemical Nickel-plating (**NW**)

Example of standard designation: **FSH 52 MT/5280/SB**

See page 9 for standard codification

Guide Rails **FSH...M, FSX...M**

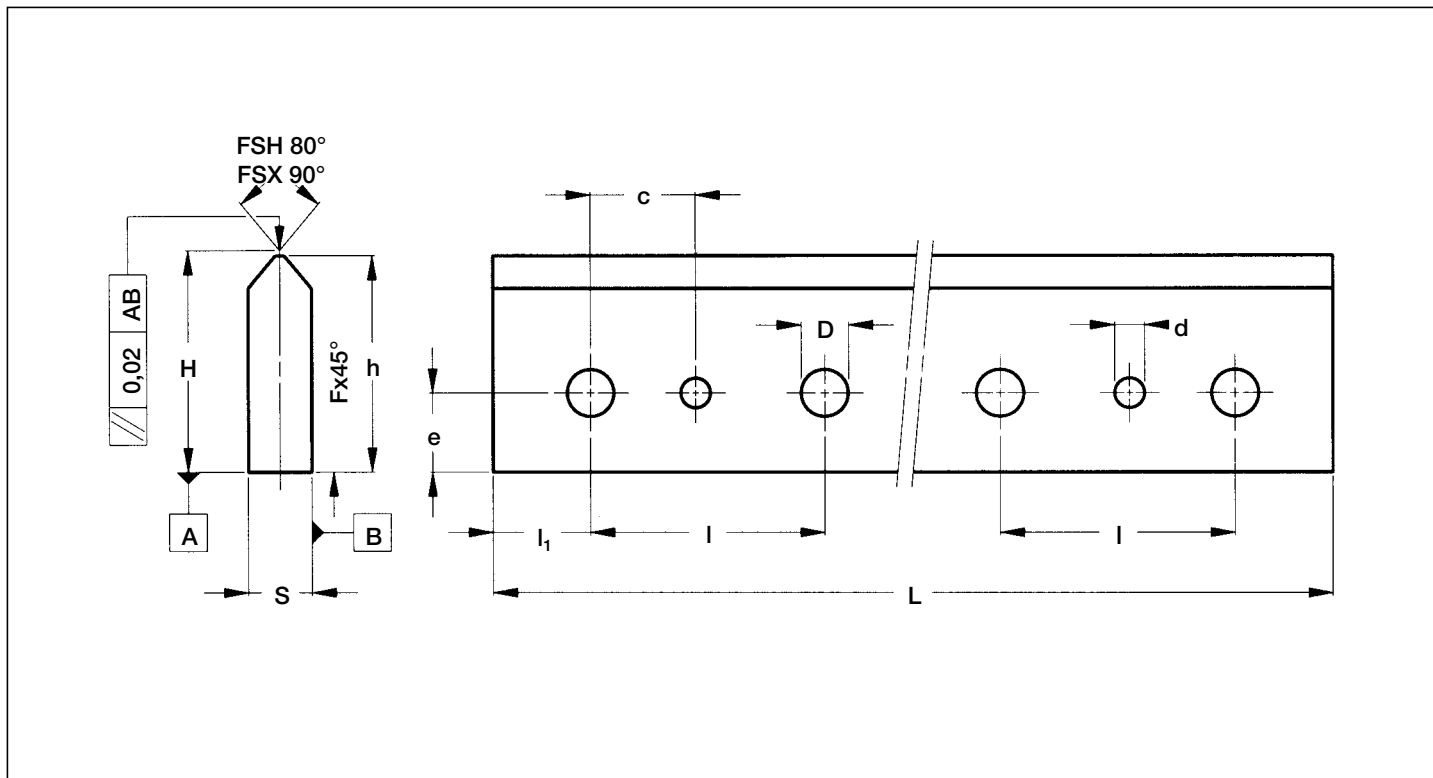

Type	Dimensions (mm)										Weight ⁽²⁾ (kg/m)
	H ± 0.05	h ± 0.1	S ± 0.05	d + 0.05	D	c	e	F ⁽³⁾	l	l ₁	
FSH 19 M	18.98	18.5	4.5	4	6.5	15	8	0.5	90	30	0.6
FSH 22 M	22.93	22.0	5.0	5	6.5	15	9	0.5	90	30	0.8
FSH 32 M	28.93	28.0	6.0	6	6.5	15	11	1.0	90	30	1.2
FSH 40 M	36.29	35.0	8.0	6	9.0	20	16	1.0	90	30	2.1
FSH 52 M	39.39	38.0	12.0	8	13.5	20	17	1.5	90	30	3.4
FSH 62 M	49.38	48.0	15.0	8	13.5	20	17	1.5	90	30	5.2
FSH 72 M	59.49	58.0	18.0	10	17.5	30	20	1.5	90	30	7.6
FSX 90 M	61.79	60.0	26.0	10	13.5	30	22	-	90	30	11.0

Maximum length of single guide element L = 4 020 mm⁽¹⁾

1) Longer rails are supplied in sections with ground butt joints

2) Weight without holes

3) Chamfer for German market only

Rails finishing

- drawn, induction hardened and ground profile (**M**);
- Induction hardening on raceways and base only

Hole layout

- holes according to catalogue (**SB**)
- finishes to drawing (**NZ**)
- without holes (**NF**)

Optional features

- ground one end (**R**)
- ground both ends (**RR**)
- chemical Nickel-plating (**NW**)

Example of standard designation: **FSH 40 M/2760/SB**

See page 9 for standard codification

Guide Rails **FSB..MT**

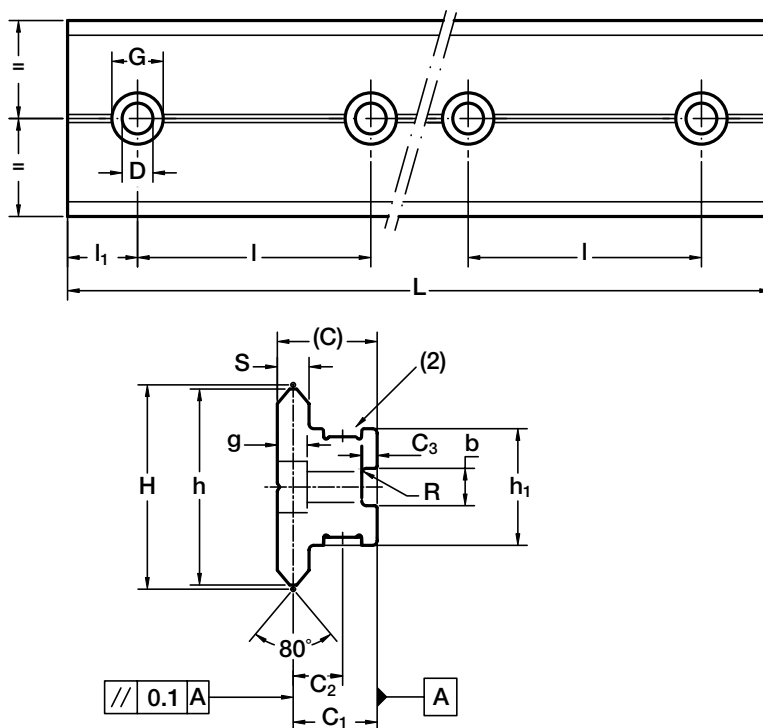

Type	Dimensions (mm)															Weight ⁽³⁾ (kg/m)
	D	G	g	l	l ₁	H ± 0.1	h ± 0.1	S ± 0.1	(C)	C ₁ ± 0.1	C ₂	C ₃	b + 0.05	h ₁	R	
FSB 32 MT	6.6	11	6.8	90	30	43.8	42	6.8	21.4	18	10.6	3.3	8	25	1	4.5
Maximum length of single guide element L = 6 000 mm ⁽¹⁾																

- 1) Longer rails are supplied in sections with ground butt joints
- 2) Option measuring tape, for more information contact technical department
- 3) Weight without holes

Rails finishing

- drawn, induction hardened and sandblasted tracks (**MT**);
- Induction hardening on raceways only

Hole layout

- holes according to catalogue (**SB**)
- finishes to drawing (**NZ**)
- without holes (**NF**)

Optional features

- ground one end (**R**)
- ground both ends (**RR**)
- chemical Nickel-plating (**NW**)

Example of standard designation: **FSB 32 MT/2040/SB**

See page 9 for standard codification

Guide Rollers **FR..EI**

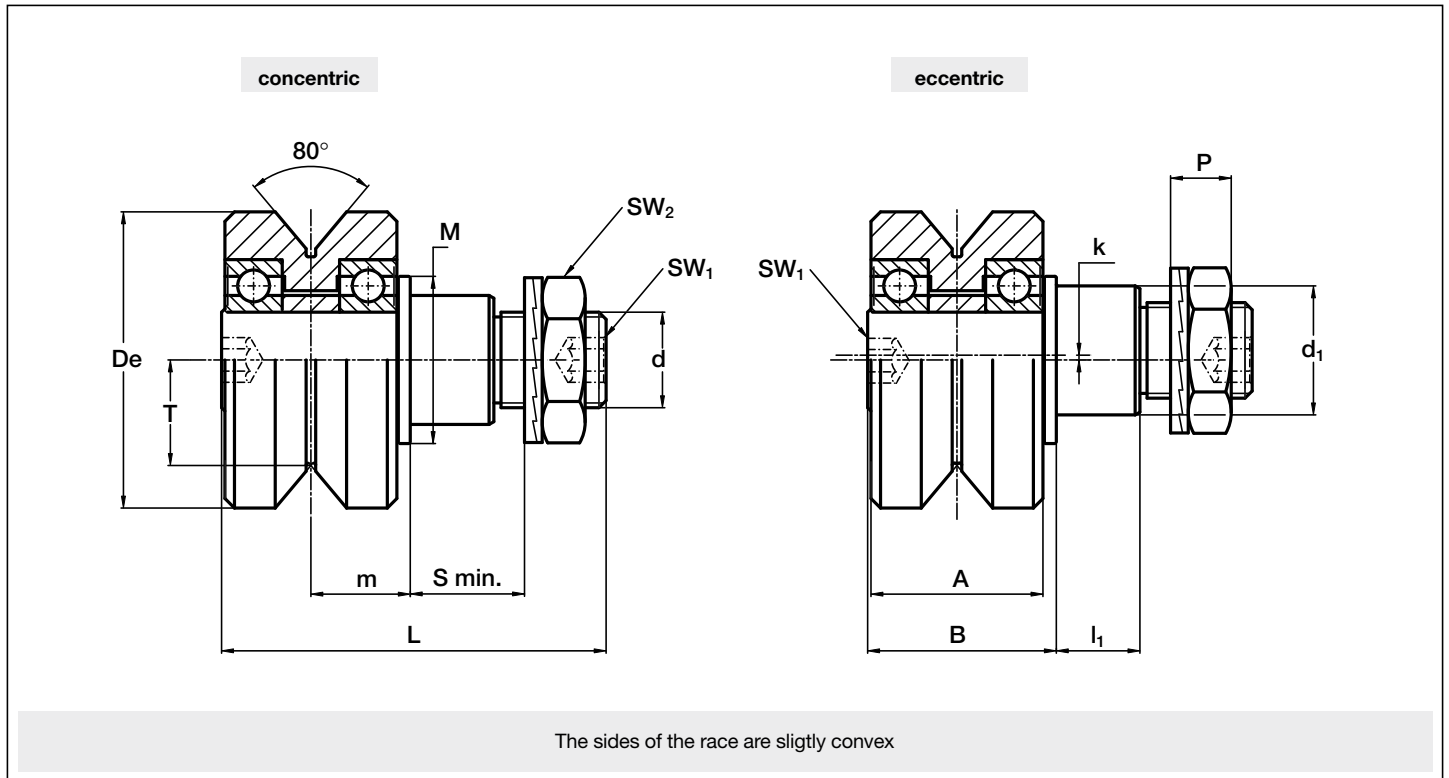

Type		Dimensions (mm)														
concentric	eccentric	De	d ₁ ⁽¹⁾	d	T	m	S min.	P	L	A	B	l ₁	M	SW ₁	SW ₂	k
FR 22 EI	FRR 22 EI	22	9	M 6 x 1	7.7	9.4	9	6.5	37	15	18.2	8	14	4	ch. 10	0.5
FR 32 EI	FRR 32 EI	32	14	M 10 x 1.25	11.8	12.6	12	8.5	50.5	21	24.5	11	20	4	ch. 16	1
FR 40 EI	FRR 40 EI	40	16	M 12 x 1.5	14.6	15.5	12	10.4	59.5	28	30.5	11	22	5	ch. 18	1
FR 52 EI	FRR 52 EI	52	21	M 16 x 1.5	19.1	19.8	15	11.4	69.5	32	36.5	14	28	6	ch. 24	1,5
FR 62 EI	FRR 62 EI	62	27	M 20 x 1.5	22.1	20.8	18.5	12.4	80.5	36	39.5	17.5	35	8	ch. 30	2

Type		Bearing rating (N)			Limit loads (N)		Life coefficients		Torque wrench settings ⁽²⁾ (Nm)	Weight (kg)
		Dynamic	Static							
			C _w ⁽⁴⁾	radial C _{or}	axial C _{oa}	radial F _r	axial F _a	X		
FR 22 EI	FRR 22 EI	1 800	1 080	350	1 700	720	1	2.20	3	45
FR 32 EI	FRR 32 EI	4 400	2 330	750	1 200	500	1	2.92	20	130
FR 40 EI	FRR 40 EI	7 350	4 000	1 300	3 000	1 300	1	2.75	26	260
FR 52 EI	FRR 52 EI	9 500	5 500	1 750	7 500	3 000	1	2.96	64	510
FR 62 EI	FRR 62 EI	15 500	8 500	2 750	10 900	4 200	1	3.07	120	820

1) Housing bore tolerance: H7

2) The torque wrench settings are given for non-lubricated threads; for lubricated threads, multiply figure by 0.8

3) On request, the guide rollers can be supplied in AISI 440 stainless steel (suffix **NX**)

4) C_w basic load for 100 km

5) The guide rollers are complete with self-locking washers and hexagonal nut (DIN 439B) for fitting

6) Pressure angle α for load calculation: 40°

7) NBR seals RS type

Guide Rollers **FRN..EI**

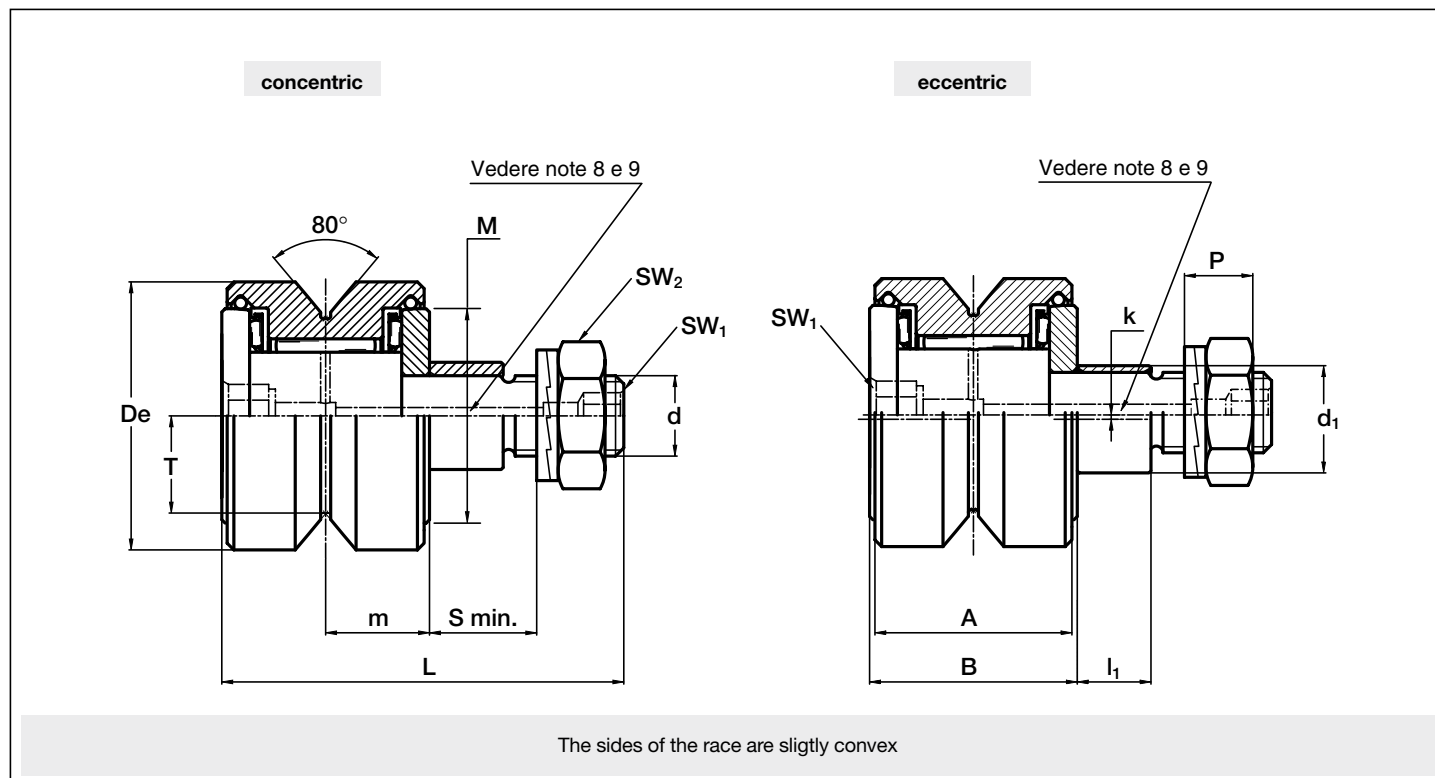

Type		Dimensions (mm)														
concentric	eccentric	De	d ₁ ⁽¹⁾	d	T	m	S min.	P	L	A	B	l ₁	M	SW ₁	SW ₂	k
FRN 19 EI	FRNR 19 EI	19	7	M 5 x 0.8	7	8.8	6.5	4.2	34	17	18	5.5	-	*	ch. 8	0.5
FRN 22 EI	FRNR 22 EI	22	9	M 6 x 1	7.7	9.4	9	6.5	39	18.2	20	8	-	*	ch. 10	0.5
FRN 32 EI	FRNR 32 EI	32	14	M 10 x 1.25	11.8	12.6	12	10.4	52	24.2	26	11	-	4	ch. 16	1
FRN 40 EI	FRNR 40 EI	40	16	M 12 x 1.5	14.6	15.5	12	11.4	60	29.4	31	11	-	8	ch. 18	1

^{*)} screwdriver slot

Type		Bearing rating (N)				Limit loads (N)		Torque wrench ⁽²⁾ settings (Nm)	Weight (g)
		Dynamic		Static		radial F _r	axial F _a		
		C _{wr} ⁽⁴⁾	C _{wa} ⁽⁴⁾	radial C _{or}	axial C _{oa}				
FRN 19 EI	FRNR 19 EI	1 800	600	1 720	1 300	490	270	1.8	35
FRN 22 EI	FRNR 22 EI	3 280	800	3 750	1 670	590	290	3	53
FRN 32 EI	FRNR 32 EI	5 600	2 100	7 200	5 100	2 030	950	20	160
FRN 40 EI	FRNR 40 EI	12 300	2 600	17 000	6 700	2 800	1 350	26	290

1) Housing bore tolerance: H7

2) The torque wrench settings are given for non-lubricated threads; for lubricated threads, multiply figure by 0.8

3) On request, the guide rollers can be supplied in AISI 440 stainless steel (suffix **NX**)

4) C_w basic load for 100 km

5) The guide rollers are complete with self-locking washers and hexagonal nut (DIN 439B) for fitting

6) Pressure angle α for load calculation: 40°

7) Standard Viton seals to fit temperature up to 120°C

Guide Rollers **FRL**

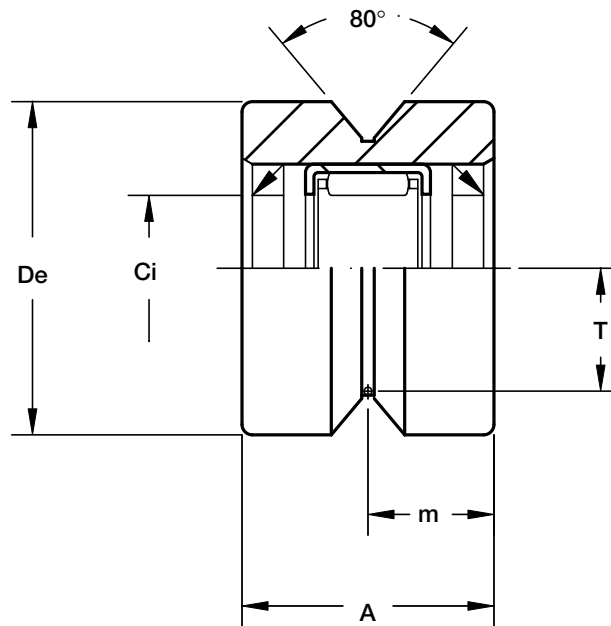
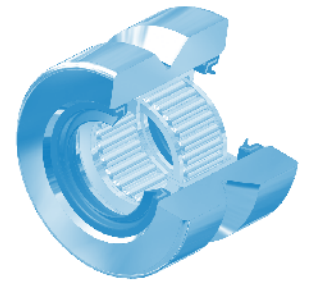

The race ways are slightly convex

Type	Dimensions (mm)				
	De	Ci	T	m	A
FRL 19	19	7	7.0	8.3	16.6
FRL 22	22	10	7.7	8.9	17.8
FRL 32	32	14	11.8	12.1	24.2
FRL 40	40	20	14.6	14.7	29.4
FRL 52	52	25	19.1	18.8	37.6
FRL 62	62	30	22.1	19.8	39.6
FRL 72	72	35	25.5	26.0	52.0

Type	Bearing rating (N)		Weight (g)
	Dynamic	Static	
	$C_w^{(1)}$	radial C_{or}	
FRL 19	1 910	930	28
FRL 22	2 860	1 500	36
FRL 32	5 620	2 900	100
FRL 40	10 600	6 400	176
FRL 52	17 700	10 500	393
FRL 62	20 500	12 400	595
FRL 72	35 400	22 000	1 076

1) C_w basic load for 100 km

2) The guide rollers are sealed on both sides

Guide Rollers **FRLK..FRLR**

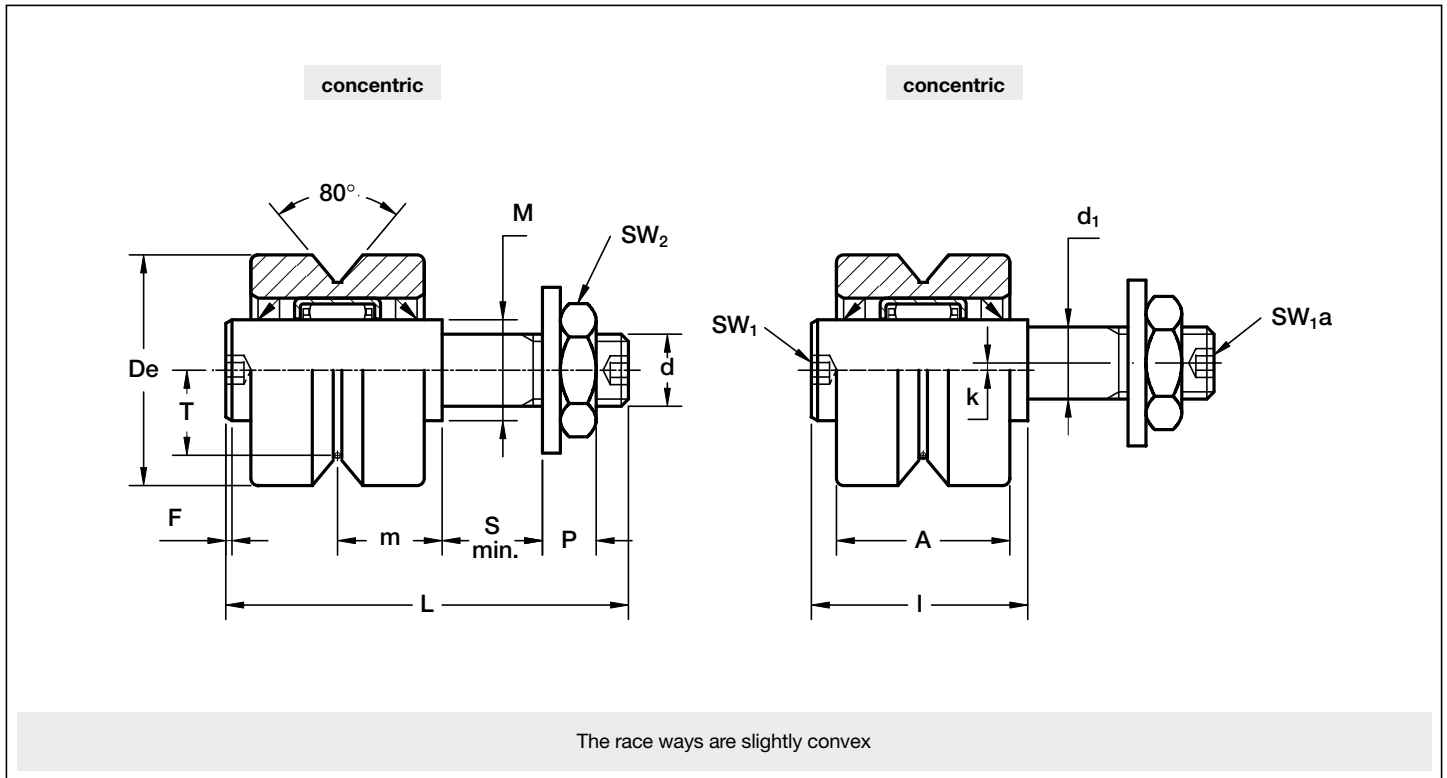
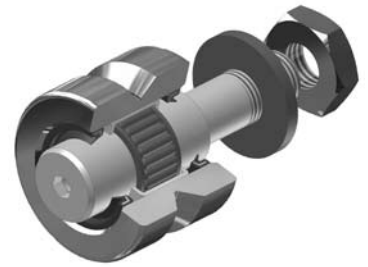

Type		Dimensions (mm)														
concentric	eccentric	De	d ₁ ⁽¹⁾	d	T	m	S min.	P	L	A	I	F	M	SW ₁	SW ₂	k
FRLK 19	FRLR 19	19	5	M 5 x 0.8	7.0	8.3	6.5	3.9	38.6	16.6	22.6	1	7	2.5	8	0.5
FRLK 22	FRLR 22	22	6	M 6 x 1.0	7.7	8.9	9.0	4.7	42.8	17.8	23.8	1	10	3.0	10	0.5
FRLK 32	FRLR 32	32	10	M 10 x 1,25	11.8	12.1	12.0	7.5	56.2	24.2	30.2	1	14	4.0	17	1.0
FRLK 40	FRLR 40	40	12	M 12 x 1.5	14.6	14.7	12.0	9.0	64.7	29.4	35.7	2	20	4.0	19	1.0
FRLK 52	FRLR 52	52	16	M 16 x 1.5	19.1	18.8	15.0	12.0	77.6	37.6	44.6	2	25	5.0	24	1.5
FRLK 62	FRLR 62	62	20	M 20 x 1.5	22.1	19.8	19.0	15.0	87.6	39.6	46.6	2	30	8.0	30	2.0
FRLK 72	FRLR 72	72	24	M 24 x 1.5	25.5	26.0	22.0	18.0	109.0	52.0	59.0	2	35	10.0	36	3.0

Type		Bearing rating (N)		Limit loads (N) Shaft	Torque ⁽²⁾ wrench setting (Nm)	Weight (g) ⁽³⁾
		Dynamic	Static			
		C _w ⁽⁴⁾	radial C _{or}	radial F _r		
FRLK 19	FRLR 19	1 910	930	240	1.8	42
FRLK 22	FRLR 22	2 860	1 500	410	3.0	60
FRLK 32	FRLR 32	5 620	2 900	1 720	20.0	160
FRLK 40	FRLR 40	10 600	6 400	2 610	26.0	300
FRLK 52	FRLR 52	17 700	10 500	5 150	64.0	627
FRLK 62	FRLR 62	20 500	12 400	9 610	120.0	967
FRLK 72	FRLR 72	35 400	22 000	13 500	220.0	1 714

1) Housing bore tolerance: H7 maximum angular deviation of drilled axis to rolling flat ±5'

2) The torque wrench settings are given for non-lubricated threads; for lubricated threads, multiply figure by 0.8

3) Weight without fittings

4) C_w basic load for 100 km

5) The guide rollers are completed with conical spring washer and nut (DIN 439B)

6) The guide rollers are sealed on both sides

Guide Rollers **RKY..RKX**

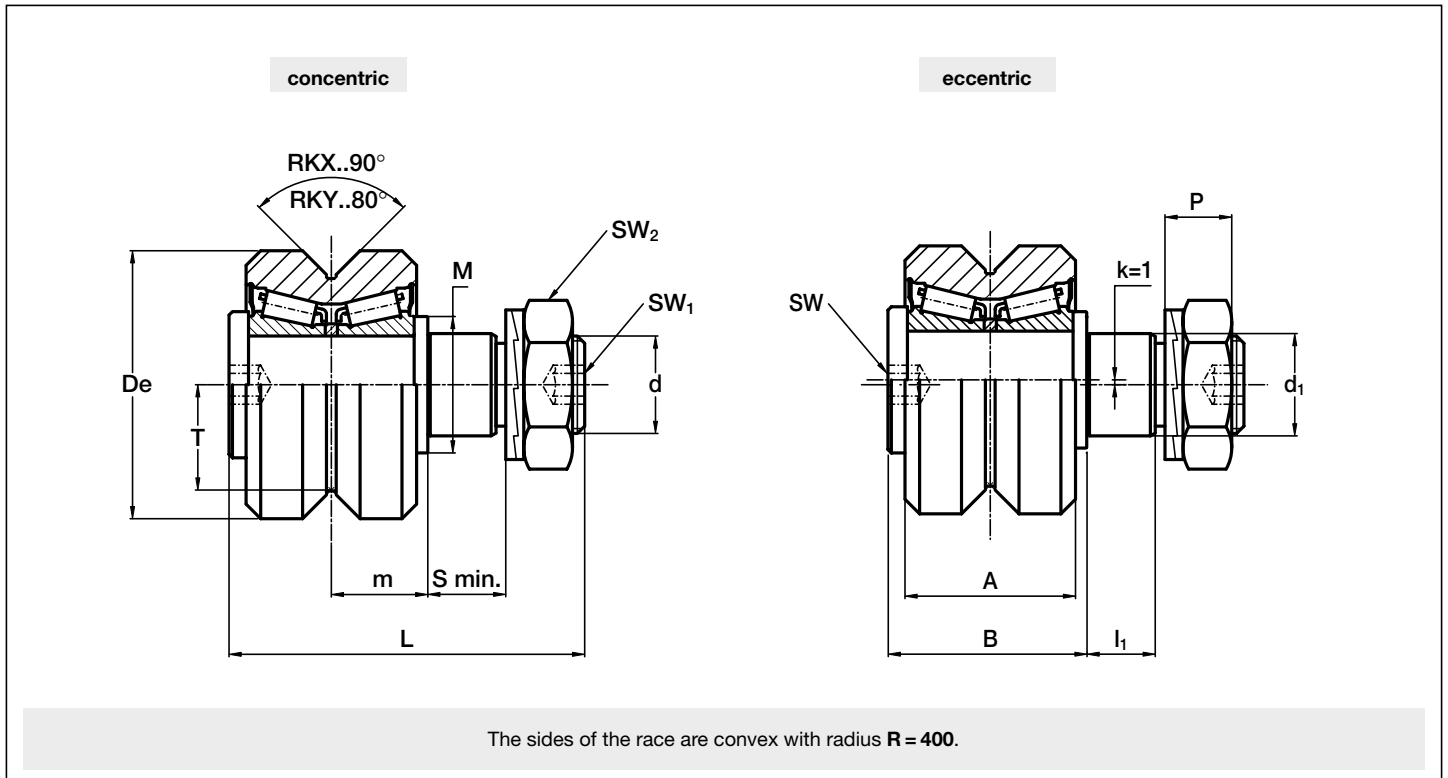

Type		Dimensions (mm)														
concentric	eccentric	De	d ₁ ⁽¹⁾	d	T	m	S min.	P	L	A	B	I ₁	M	SW ₁	SW ₂	k
RKY 52	RKYR 52	52	21	M 20 x 1.5	19.1	19.8	15	13.7	73	35	41	14	28	8	ch. 30	1
RKY 62	RKYR 62	62	27	M 24 x 1.5	22.1	20.8	19	15.7	83	37	44	18	35	10	ch. 36	1
RKY 72	RKYR 72	72	36	M 30 x 1.5	25.5	27	19	21.6	100	45	55	18	44	12	ch. 46	1
RKX 90C	RKXR 90C	90	38	M 36 x 1.5	32.5	30	24	24.6	115	53	62	23	50	14	ch. 55	1
RKX 110C	RKXR 110C	110	42	M 36 x 1.5	39.5	34	33	24.6	135	60	70	32	56	14	ch. 55	1

Type		Bearing rating (N)			Limit loads (N)		Life coefficients				Torque wrench settings ⁽²⁾ (Nm)	Weight (kg)
		Dynamic	Static				Pa/Pr ≤ 0.1		Pa/Pr > 0.1			
			C _w ⁽⁵⁾	radial C _{or}	axial C _{oa}	radial F _r	axial F _a	X	Y	X		
RKY 52	RKYR 52	40 750	44 000	12 400	11 900	4 250	1	4.67	0.77	6.98	80	0.6
RKY 62	RKYR 62	46 000	50 400	12 750	22 100	6 800	1	3.93	0.74	6.55	160	0.9
RKY 72	RKYR 72	64 850	72 000	18 900	31 300	10 100	1	4.67	0.77	6.98	300	1.6
RKX 90C	RKXR 90C	113 400	136 000	37 800	43 700	12 600	1	3	0.8	4.96	450	2.8
RKX 110C	RKXR 110C	177 500	195 000	50 000	55 600	17 900	1	4.26	0.72	7.1	450	4.9

- Housing bore tolerance: H7
- The torque wrench settings are given for non-lubricated threads; for lubricated threads, multiply figure by 0.8
- Standard seals: material NBR, RS type
- On request, the guide rollers can be supplied in AISI 440 stainless steel (suffix **NX**) and with Viton seals for operating temperatures up to 120 °C (suffix **V**)
- C_w basic load for 100 km
- Dimensions relating to the stainless-steel rollers (suffix **NX**)
- The guide rollers are complete with self-locking washers and hexagonal nut (DIN 439B) for fitting
- Pressure angle α for load calculation: guide rollers RKY 40° - guide rollers RKX 45°

Guide Wheels **FKY..FKX**

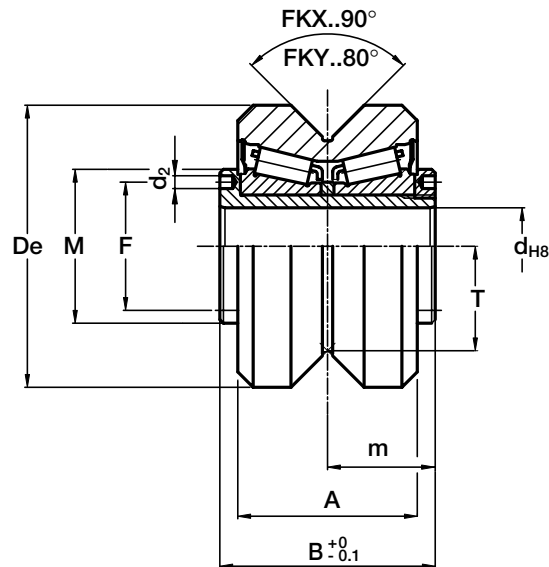

The sides of the race are convex with radius $R = 400$.

Type	Dimensions (mm)									Weight (kg)
	De	d	T	m	A	B	F	d ₂	M	
FKY 52C	52	15	14.6	21	35	42	25	2.5	30	0.5
FKY 62C	62	20	18	22.5	37	45	29	3	35	0.6
FKY 72C	72	25	23.7	28	45	56	37	4	44	1.2
FKX 90C	90	28	32.5	32	53	56 ⁽²⁾⁻⁻⁻	64	4	49	2.3
FKX 110C	110	35	39.5	36	60	63 ⁽²⁾⁻⁻⁻	72	4	59	3.9

Type	Bearing rating (N)			Life coefficients			
	Dynamic	Static		Pa/Pr ≤ 0.1		Pa/Pr > 0.1	
	C _w ⁽³⁾	radial C _{or}	axial C _{oa}	X	Y	X	Y
FKY 52C	40 750	44 000	12 400	1	4.67	0.77	6.98
FKY 62C	46 000	50 400	12 750	1	3.93	0.74	6.55
FKY 72C	64 850	72 000	18 900	1	4.67	0.77	6.98
FKX 90C	113 400	136 000	37 800	1	3	0.8	4.96
FKX 110C	177 550	195 000	50 000	1	4.26	0.72	7.1

- 1) On request, the guide rollers can be supplied in AISI 440 stainless steel (suffix **NX**) and with Viton seals for operating temperatures up to 120 °C (suffix **V**)
- 2) Dimensions relating to the stainless-steel rollers (suffix **NX**)
- 3) C_w basic load for 100 km
- 4) To prevent rotation between roller and shaft a pin can be fitted in one of the holes "d₂" positioned in the side flange
- 5) Pressure angle α for load calculation: guide rollers RKY 40° - guide rollers RKX 45°
- 6) Standard seals: material NBR, RS type

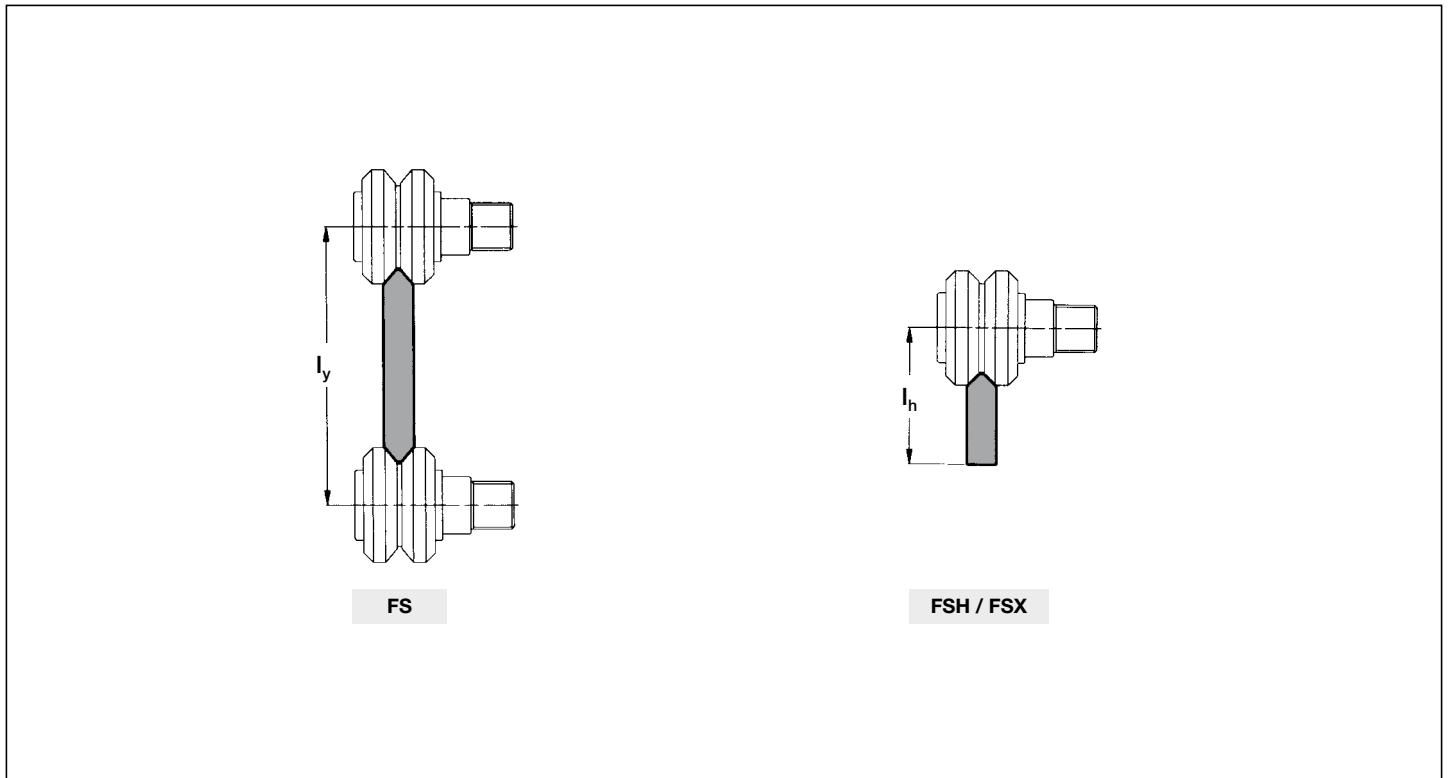

Guide Rollers FR...EI, FRN...EI, RKY, RKX, FKY, FRN, FRL, FRLK

	ly (mm)	Guide roller size						
		19...	22...	32...	40...	52...	62...	72...
FS..M	FS 19 M	35	36.4					
	FS 22 M	41.9	43.3					
	FS 32 M			66.5				
	FS 35 M			71.5	*77			
	FS 40 M				92.8			
	FS 47 M					116.8		
	FS 52 M					128	*134	
	FS 62 M					143	149	
	FS 72 M						*167.2	174

	lh (mm)	Guide roller size									
		19...	22...	32...	40...	52...	62...	72...	90...	110...	
FSH..M, FSX..M	FSH 19 M	26	26.7								
	FSH 22 M	*29.9	30.6								
	FSH 32 M			40.7							
	FSH 40 M			*48.1	50.9						
	FSH 52 M				*54	58.5					
	FSH 62 M					*68.5	71.5				
	FSH 72 M						*81.6	85			
	FSX 90 M								94.3	101.3	

	ly (mm)	Guide roller size						
		19...	22...	32...	40...	52...	62...	72...
FS..MT	FS 19 MT	36.2	37.6					
	FS 22 MT		44.2					
	FS 32 MT			67.4				
	FS 35 MT			72.4	*78			
	FS 40 MT				93.7			
	FS 47 MT					118.3		
	FS 52 MT					129.5	*135.5	
	FS 62 MT					144.2	150.2	
	FS 72 MT						*168.8	175.6

	lh (mm)	Guide roller size									
		19...	22...	32...	40...	52...	62...	72...	90...	110...	
FSH..MT, FSX..MT	FSH 22 MT	30.9	31.6								
	FSH 32 MT			41.7							
	FSH 40 MT			*49	51.8						
	FSH 52 MT				*55.4	59.9					
	FSH 62 MT					*69.9	72.9				
	FSH 72 MT						*83	86.4			
	FSX 90 MT								95.3	102.3	

* possible combination

- Handling device for a plastic moulding machine.

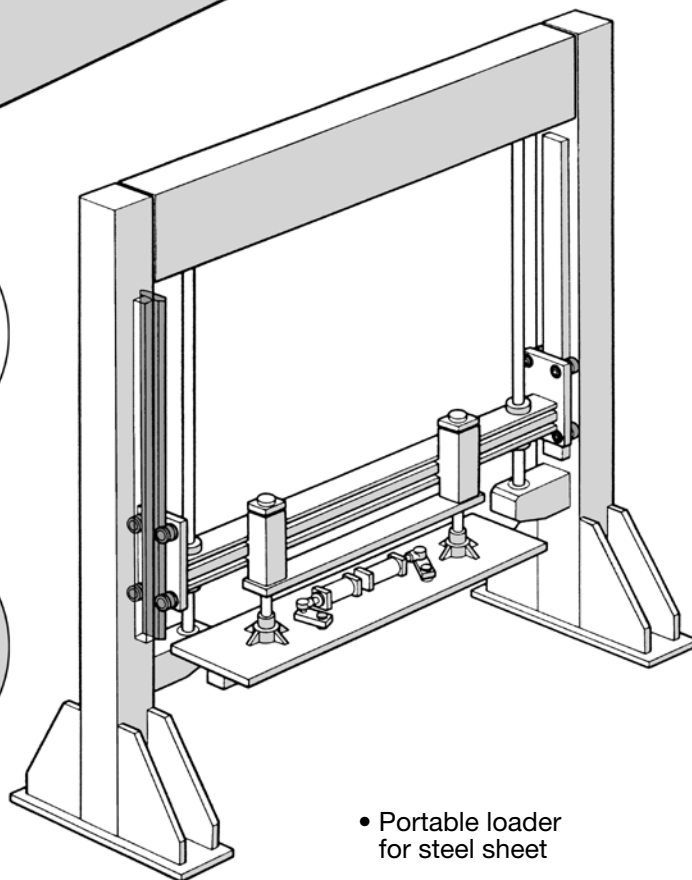
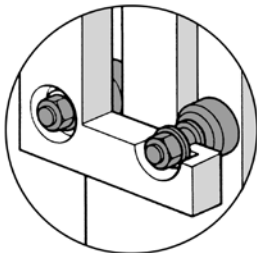
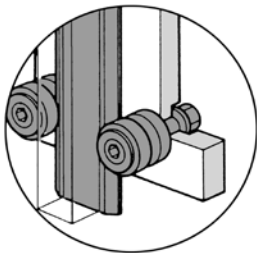
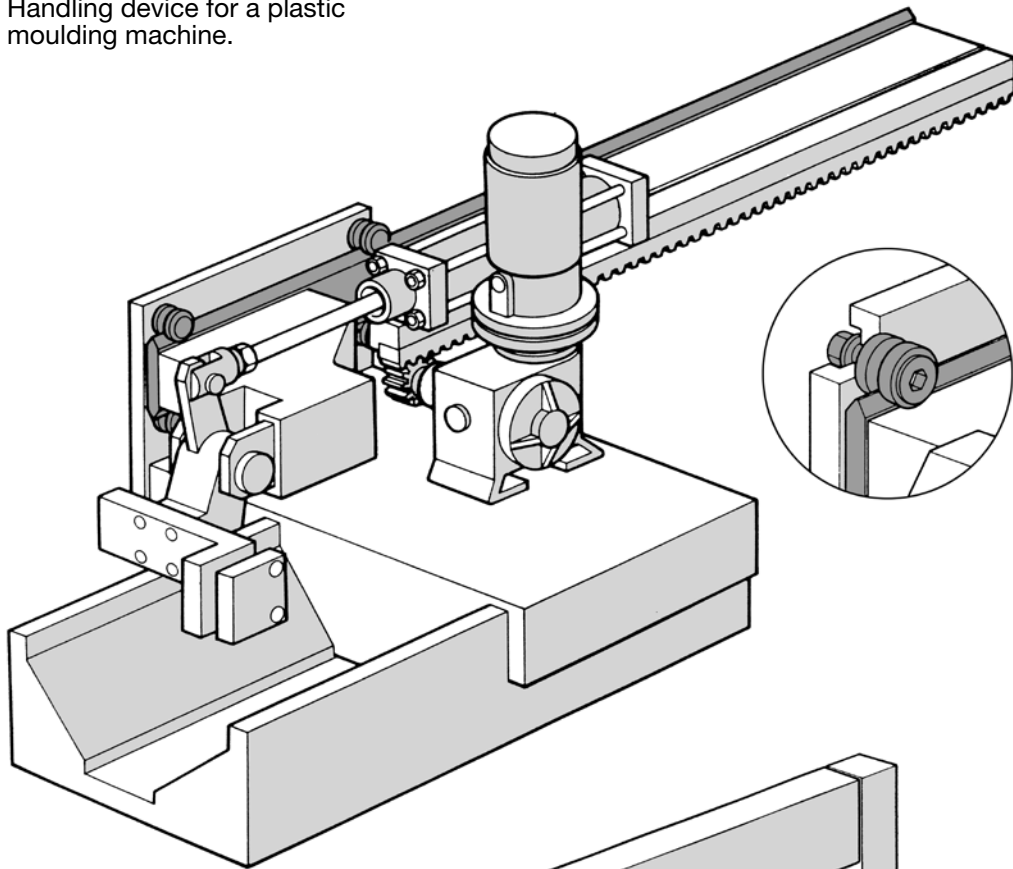

- Portable loader for steel sheet

GP System



NADELLA

Guide Rails GP..ML - GP..MT

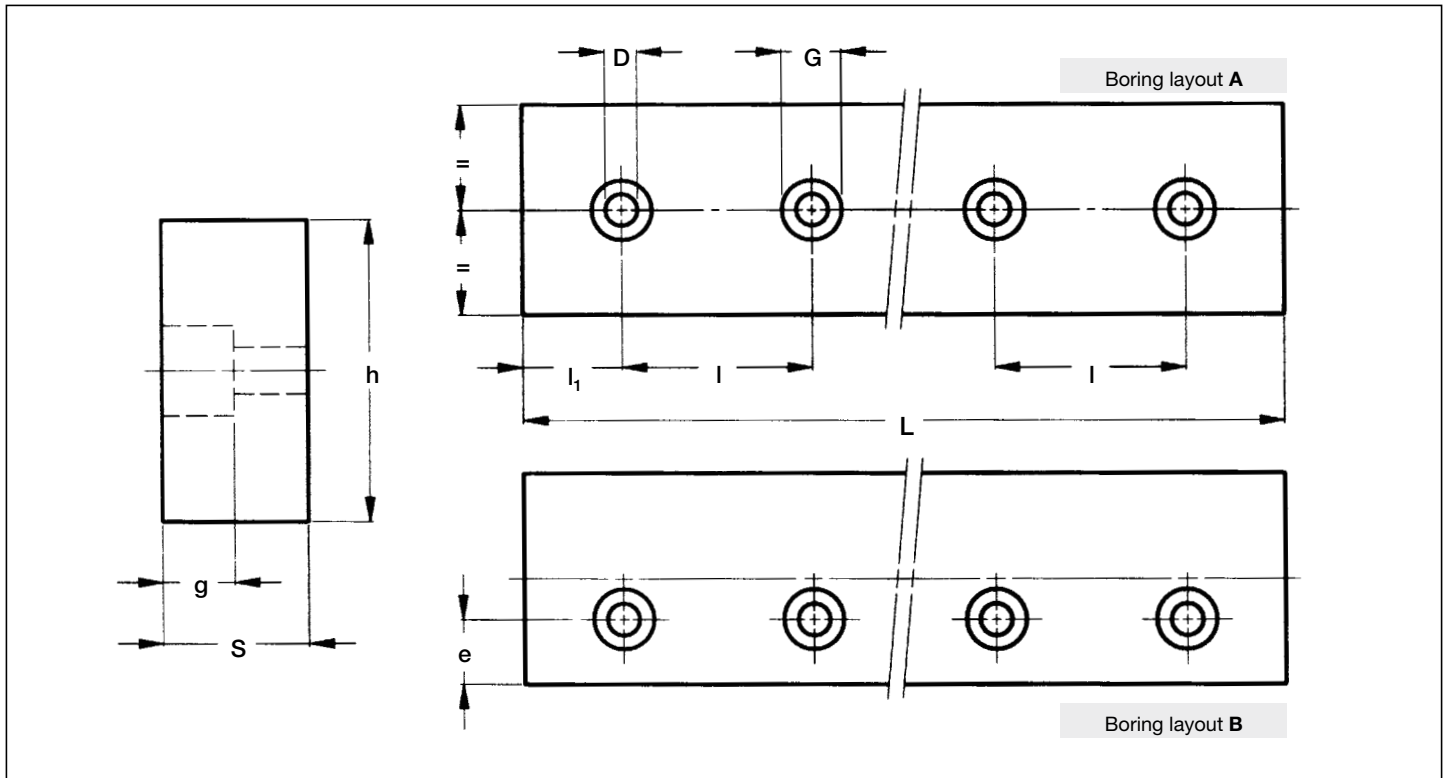

Type	Dimensions (mm)								Weight ⁽³⁾ (kg/m)
	h ± 0.2	S ± 0.2	D	G	g	e	l	l ₁	
GP 2626 ML	26	26	9	15	9	(4)	120	50	5.3
GP 3232 ML	32	32	9	15	9	(4)	150	60	8.1
GP 3617 MT	36	17	6.5	11	6.8	12.5	120	50	4.8
GP 4321 ML ⁽⁴⁾	43	21	9	15	9	11.5	150	60	7
GP 6222 ML	62	22	9	15	9	21	150	60	10.7
GP 7232 ML	72	32	13.5	20	13	24	180	70	18.1
GP 8222 ML	82	22	13.5	20	13	20	180	70	14.2

max length of single guide element L = 6 000 mm ⁽¹⁾

1) longer rails are supplied in sections with ground butt joints (max. length with treatment NW on request)

2) other dimensions on request - 3) Weight without holes - 4) Only available according to figure A

5) max length as single element 5.5 m. gross grinding on the four sides.

Rails finishing

- material: GP..ML: C60, GP..MT CK45
- induction hardened tracks
- decarburization measured in the middle part of the surface-surface: 1-3% of the dimensions (decreased hardness)

Hole layout

- holes according to catalogue (**SB**)
- finishes to drawing (**NZ**)
- without holes (**NF**)

Optional features

- ground one end (**R**)
- ground both ends (**RR**)
- chemical Nickel-plating (**NW**)

Example of standard designation: **GP 6222 ML/4300/SB**

See page 9 for standard codification

Guide Rails GP..M

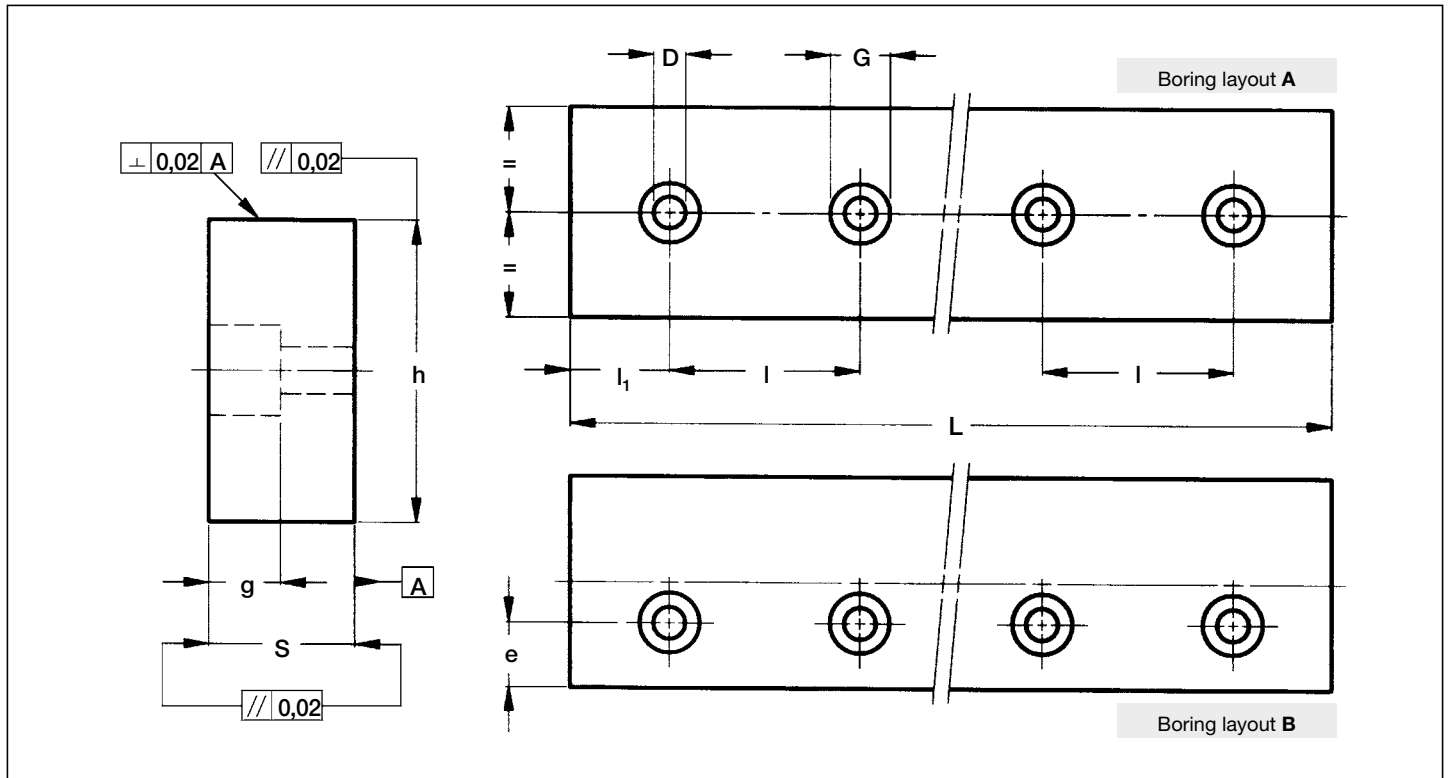

Type	Dimensions (mm)								Weight ⁽³⁾ (kg/m)
	h ± 0.05	S ± 0.05	D	G	g	e	l	l ₁	
GP 2525 M	25	25	9.0	15	8.5	(4)	120	50	4.9
GP 3131 M	31	31	9	15	8.5	(4)	150	60	7.5
GP 3516 M	35	16	6.5	11	6.8	12	120	50	4.4
GP 4220 M	42	20	9	15	9	11	150	60	6.5
GP 6121 M	61	21	9	15	9	20.5	150	60	10
GP 7131 M	71	31	13.5	20	12.5	23.5	180	70	17.3
GP 8121 M	81	21	13.5	20	13	19.5	180	70	13.4

max length of single guide element L = 4,020 mm ⁽¹⁾

1) longer rails are supplied in sections with ground butt joints (max. length with treatment NW on request)

2) other dimensions on request - 3) Weight without holes - 4) Only available according to figure A

Rails finishing

- material: GP..ML: C60, GP..MT: CK45
- induction hardened and ground tracks (**M**);

Hole layout

- holes according to catalogue (**SB**)
- finishes to drawing (**NZ**)
- without holes (**NF**)

Optional features

- ground one end (**R**)
- ground both ends (**RR**)
- chemical Nickel-plating (**NW**)

Example of standard designation: **GP 6121 M/2070/B**

See page 9 for standard codification

Guide Rollers **PK**

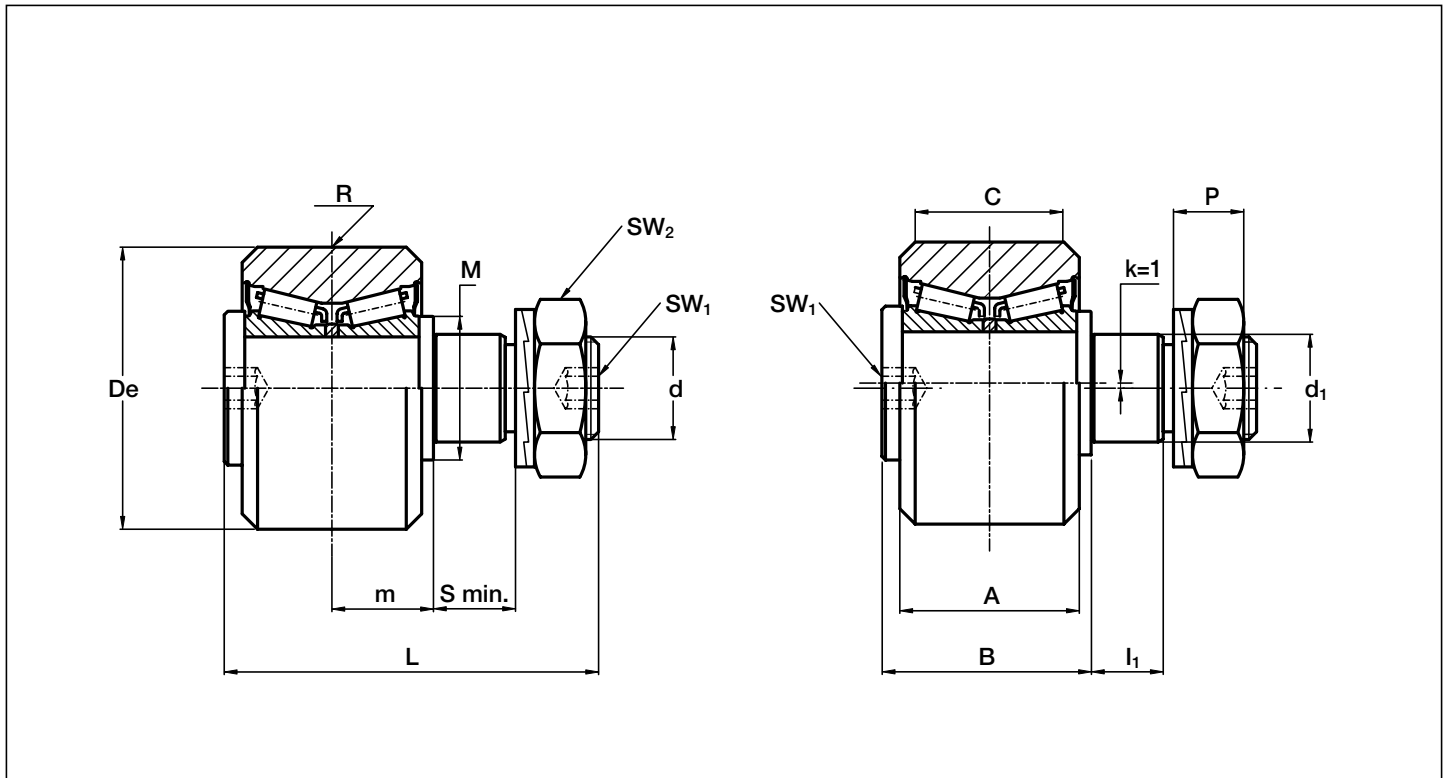

Type		Dimensions (mm)																
concentric	eccentric	De	d ₁ ⁽¹⁾	d	m	S min.	P	L	A	B	C	R	I ₁	M	SW ₁	SW ₂	k	
PK 52C	PKR 52C	52	21	M 20 x 1.5	19.8	15	13.4	73	35	41	29	800	14	28	8	ch. 30	1	
PK 62C	PKR 62C	62	27	M 24 x 1.5	20.8	19	15.4	83	37	44	29	800	18	35	10	ch. 36	1	
PK 72C	PKR 72C	72	36	M 30 x 1.5	27	19	21.6	100	45	55	33	1 200	18	44	12	ch. 46	1	
PK 90C	PKR 90C	90	38	M 36 x 1.5	30	24	24.6	115	53	56 ⁽⁵⁾	62	45	1 200	23	50	14	ch. 55	1
PK 110C	PKR 110C	110	42	M 36 x 1.5	34	33	24.6	135	53	63 ⁽⁵⁾	70	48	1 200	32	56	14	ch. 55	1

Type		Bearing rating (N)		Limit loads (N)	Torque ⁽²⁾ wrench setting (Nm)	Weight (Kg)
		Dynamic	Static			
		C _w ⁽⁶⁾	C _o			
PK 52C	PKR 52C	42 100	44 000	11 900	80	0.6
PK 62C	PKR 62C	47 750	50 400	22 100	160	0.9
PK 72C	PKR 72C	67 450	72 000	31 300	300	1.6
PK 90C	PKR 90C	118 000	136 000	43 700	450	2.8
PK 110C	PKR 110C	185 000	195 000	55 600	450	4.9

1) Housing bore tolerance: H7

2) The torque wrench settings are given for non-lubricated threads; for lubricated threads, multiply figure by 0.8

3) Standard seals: material NBR, RS type

4) On request, the guide rollers can be supplied in AISI 440 stainless steel (suffix **NX**) and with Viton seals for operating temperatures up to 120 °C (suffix **V**)

5) Dimensions relating to the stainless-steel rollers (suffix **NX**)

6) C_w basic load for 100 km

7) The guide rollers are complete with self-locking washers and hexagonal nut (DIN 439b) for fitting

Guide Wheels **FK**

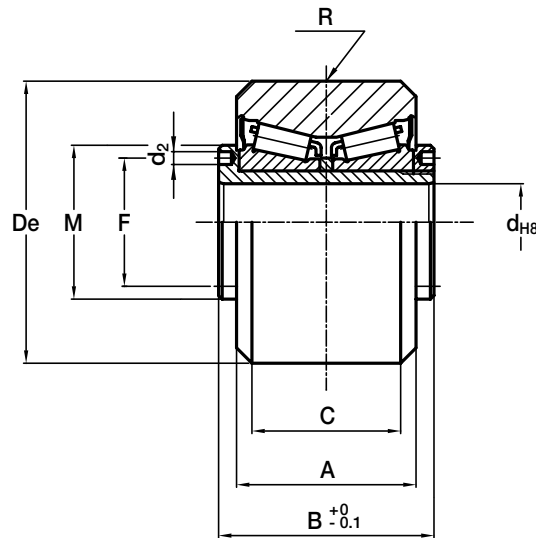

Type	Dimensions (mm)								
	De	d	A	B	C	R	F	d ₂	M
FK 52C	52	15	35	42	29	800	25	2.5	30
FK 62C	62	20	37	45	29	800	29	3	35
FK 72C	72	25	45	56	33	1 200	37	4	44
FK 90C	90	28	53	56 ⁽³⁾	64	1 200	42	4	49
FK 110C	110	35	60	63 ⁽³⁾	72	1 200	52	4	59

Type	Bearing rating (N)		Weight (kg)
	Dynamic	Static	
	C _w ⁽⁴⁾	radial C ₀	
FK 52C	42 100	44 000	0.5
FK 62C	47 750	50 400	0.6
FK 72C	67 450	72 000	1.2
FK 90C	118 000	136 000	2.3
FK 110C	185 000	195 200	3.9

1) Standard seals: material NBR, RS type

2) On request, the guide rollers can be supplied in AISI 440 stainless steel (suffix **NX**) and with Viton seals for operating temperatures up to 120 °C (suffix **V**)

3) Dimensions relating to the stainless-steel rollers (suffix **NX**)

4) C_w basic load for 100 km

5) To prevent rotation between roller and shaft a pin can be fitted in one of the holes “d₂” positioned in the side flange

Guide Rollers GC



concentric

GC
GC...EE with plastic seals
GC...EEM with metal seals

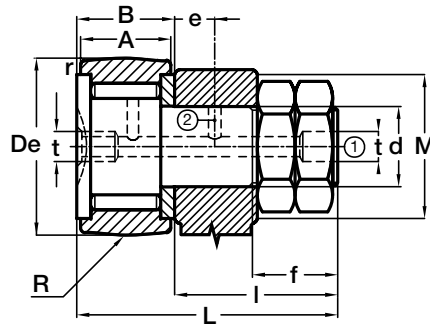

eccentric

GCR
GCR...EE with plastic seals
GCR...EEM with metal seals

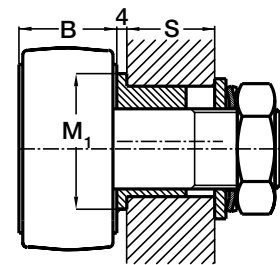
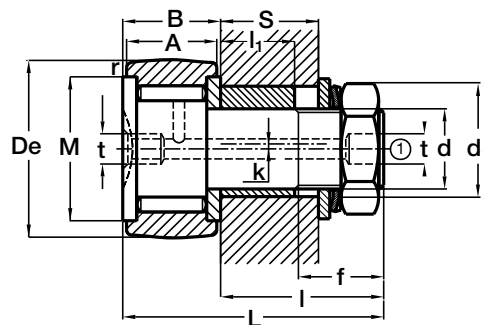

Holes ① and ② beginning from De=30 mm

Type (1)		Dimensions (mm)																
		De	A	B max	d	d ₁ (7)	k	L max	l max	f	pitch	r min	t	e	M (6)	M ₁	P (2)	l ₁
GC 19	GCR 19	19	11	12.2	8	11	0.5	32.7	20,5	10	1.25	0.3	4	-	15.3	-	-	10
GC 22	GCR 22	22	12	13.2	10	14	1	36.7	23,5	12	1.25*	0.3	4	-	18.2	-	-	11
GC 24	GCR 24	24	12	13.2	10	14	1	36.7	23,5	12	1.25*	0.3	4	-	18.2	-	-	11
GC 26	GCR 26	26	12	13.2	10	14	1	36.7	23,5	12	1.25*	0.3	4	-	20.8	-	-	11
GC 28	GCR 28	28	12	13.2	10	14	1	36.7	23,5	12	1.25*	0.3	4	-	20.8	-	-	11
GC 30	GCR 30	30	14	15.2	12	16	1	40.7	25,5	13	1.5	0.6	(9)	6	24.8	-	8	11
GC 32	GCR 32	32	14	15.2	12	16	1	40.7	25,5	13	1.5	0.6	(9)	6	24.8	-	8	11
GC 35	GCR 35	35	18	19.6	16	21	1,5	52.6	33	17	1.5	0.6	6	8	28.8	-	10	14
GC 40	GCR 40	40	20	21.6	18	24	1,5	58.6	37	19	1.5	1	6	8	33.8	-	12	16
GC 47	GCR 47	47	24	25.6	20	27	2	66.6	41	21	1.5	1	6	9	38.7	-	14	17.5
GC 52	GCR 52	52	24	25.6	20	27	2	66.6	41	21	1.5	1	6	9	38.7	-	14	17.5
GC 62	GCR 62	62	29	30.6	24	36	3	80.6	50	25	1.5	1	6	11	52	44	12	18

* These threads may be supplied with the old pitch of 1 mm (clamping torque 13 Nm)

- Housing bore tolerance: H7

- The guide rollers are complete with washers and hexagonal nut for fitting

- 1) Specification for followers with cylindrical outer ring: GCL, GCL...EE, GCL...EEM. On request the followers can be supplied possessing a screw driver slot at the threaded end of the stud (suffix **AK**).
- 2) Followers with outer diameter up to 28 mm possess a screw driver slot, above they possess an hexagonal socket.
- 3) The load shown is limited by the strengths of the stud and outer ring.
- 4) With oil lubrication of followers without seals GC, GCR, GCL e GCRL, these speeds can be increased by 30% for continuous rotation or up to 50% momentarily.
- 5) These torques are shown for dry threads. For lubricated threads, take 0,8 of these values.
- 6) Minimum recommended abutment diameter in case of high axial load or in the presence vibrations.
- 7) The eccentric collar is tightly fitted on the follower stud.
- 8) C_w basic load for 100 Km
- 9) $t=6$ for followers with slot for screw drivers, $t=4$ for followers with hexagon socket

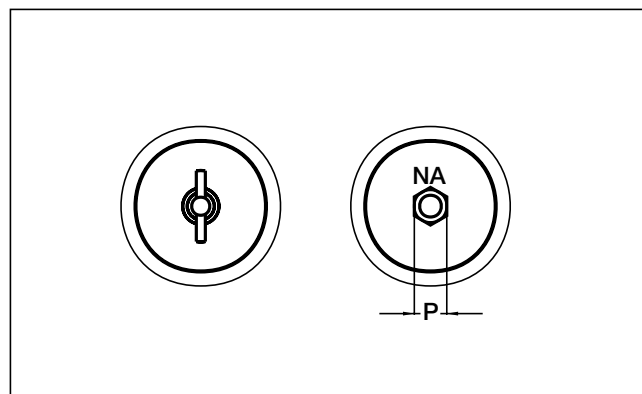

S		R	Bearing rating (N)		Limit load (3) (N)				Speed limit grease lubrication r.p.m. (4)	Torque wrench setting (Nm) (5)	
			Dynamic	Static	GC...		GCR...			GC...	GCR...
					C_w (8)	C_o	Din. F	Stat. F _o			
10.5	13	160	4 900	7 800	2 830	5 200	2 830	4 500	7 600	8	5
11.5	14	200	5 600	9 700	4 900	8 100	4 900	5 600	6 300	20	16
11.5	14	200	6 300	9 700	5 200	9 200	5 200	5 600	6 300	20	16
11.5	14	200	8 400	12 500	5 200	9 600	5 200	6 100	5 500	20	16
11.5	14	200	9 200	12 500	5 200	9 600	5 200	6 100	5 500	20	16
11.5	14.5	250	12 700	17 900	7 700	14 300	7 700	10 400	4 800	26	22
11.5	14.5	250	13 800	17 900	7 700	14 300	7 700	10 400	4 800	26	22
14.5	19	320	19 800	33 000	11 400	24 000	11 000	11 000	3 850	64	55
16.5	22	400	21 400	41 000	14 200	27 000	12 300	12 300	3 150	90	75
18	25	500	31 800	65 000	21 400	40 000	21 400	23 700	2 700	120	100
18	25	500	39 400	65 000	21 400	40 000	21 400	23 700	2 700	120	100
18.5	25.5	640	51 300	85 000	31 000	57 500	28 800	28 800	2 330	220	180

On request track rollers can be supplied in stainless steel (suffix **NX**)

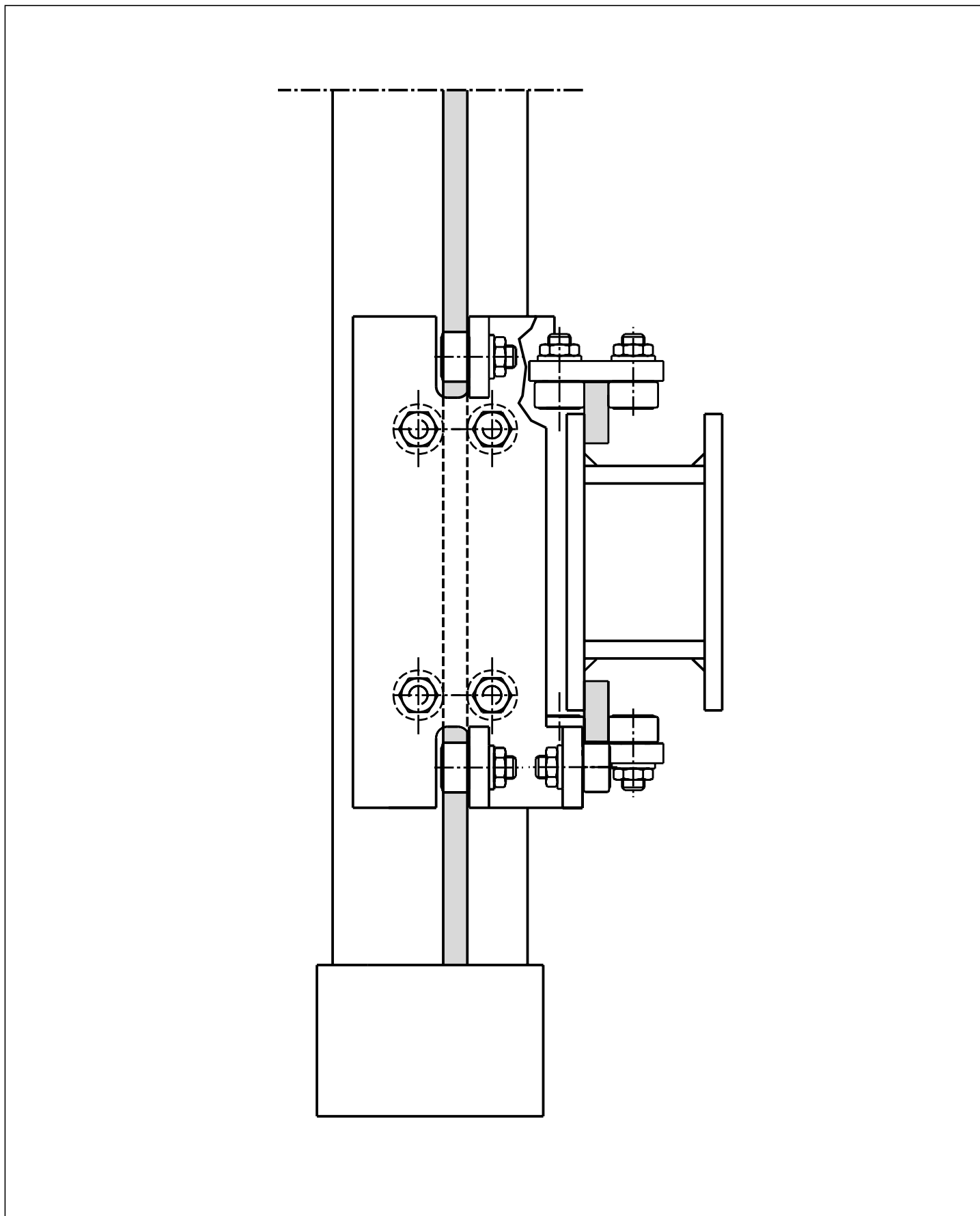

DC, C System



NADELLA

Guide Rails DC

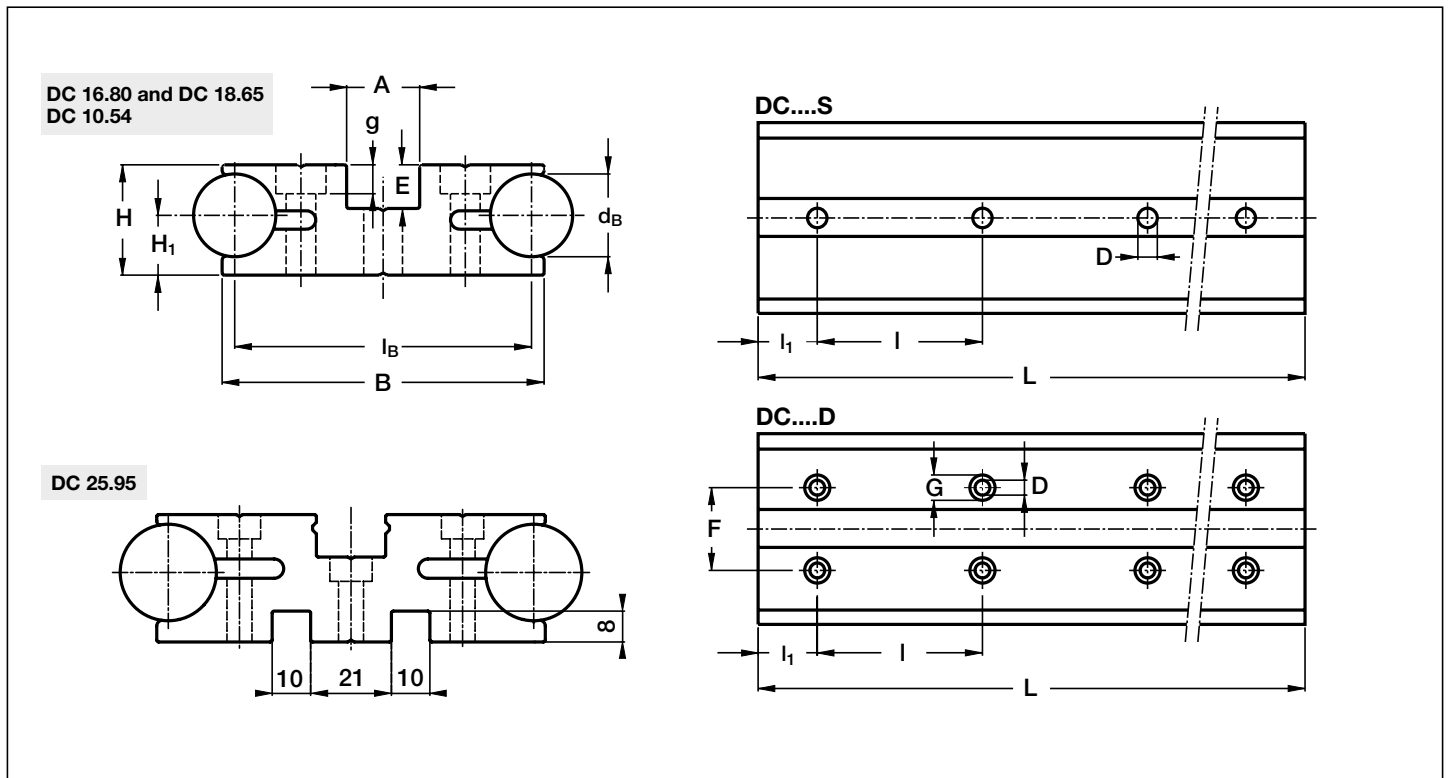

Type	Dimensions (mm)													Moments of inertia ⁽²⁾ (cm ⁴)		Weight (kg/m)
	d _B	l _B	B	H	H ₁	A	E	D	G	g	F	l	l ₁	J _x	J _y	
DC 10.54 S ⁽³⁾	10	54	57	19.5	13	25	10.5	6.5	-	-	-	150	30	2.16	20.5	2.53
DC 10.54 D ⁽³⁾	10	54	57	19.5	13	25	10.5	4.4	8	4.2	36	150	30	2.16	20.5	2.53
DC 16.80 S ⁽³⁾	16	80	86	25.5	14.5	18	9.5	8.5	-	-	-	150	30	9.6	85	7.1
DC 16.80 D ⁽³⁾	16	80	86	25.5	14.5	18	9.5	6.5	11	6.3	54	150	30	9.6	85	7.1
DC 18.65 S	18	65	70.5	24	13	16	9.5	8.5	-	-	-	150	30	6.1	34.7	7.
DC 18.65 D	18	65	70.5	24	13	16	9.5	6.5	11	6.3	36	150	30	6.1	34.7	7.
DC 25.95 S ^{(4) (3)}	25	95	101	33	18	19	13	10.5	-	-	-	150	30	21.8	142.2	13.5
DC 25.95 D ^{(4) (3)}	25	95	101	33	18	19	13	6.5	11	6.3	58	150	30	21.8	142.2	13.5

max length in single element L=6000 ⁽¹⁾

1) longer rails are supplied in sections with ground butt joints and, on request, with pin connection

2) Inertia value based on equivalent aluminium yield 70000 N/mm²

3) available with stainless steel shafts

4) available with hollow shafts

Hole layout

- holes according to catalogue (SB)
- finishes to drawing (NZ)
- without holes (NF)

Optional features

- ground one end (R)
- ground both ends (RR)
- Stainless steel shafts (NX)
- Chromium plated shafts (CH)

Example of standard designation: **DC2595 S/2010/SB/NX**

See page 9 for standard codification

Guide Rails C

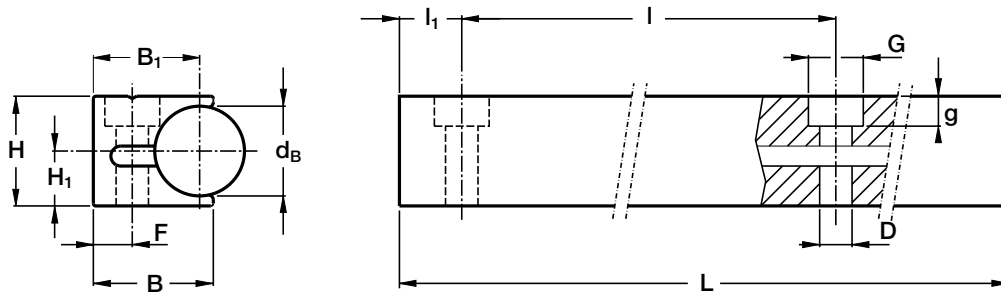

Type	Dimensions (mm)											Moments of inertia ⁽²⁾ (cm ⁴)		Weight (kg/m)
	d _B	B	B ₁	H	H ₁	D	G	g	F	l	l ₁	J _x	J _y	
C 10 ⁽³⁾	10	16.9	15.4	14.5	8	4.4	8	4.2	6.5	100	30	0.4	0.3	1.1
C 18	18	24	21.3	22	11	6.5	11	6.3	7.8	150	50	1.7	1.1	2.8
C 22	22	28	25	26.5	13.5	6.5	11	6.3	9	160	50	3.5	2.0	4.1
C 30 ^{(3) (4)}	30	36	32.5	36	19	9	15	8.3	11.5	180	60	11.1	5.6	7.6

max length in single element L=6000 ⁽¹⁾

1) longer rails are supplied in sections with ground butt joints and, on request, with pin connection

2) Inertia value based on equivalent aluminium yield 70000 N/mm²

3) available with stainless steel shafts

4) available with hollow shafts

Hole layout

- holes according to catalogue (**SB**)
- finishes to drawing (**NZ**)
- without holes (**NF**)

Optional features

- ground one end (**R**)
- ground both ends (**RR**)
- Stainless steel shafts (**NX**)
- Chromium plated shafts (**CH**)

Example of standard designation: **C10/2060/SB**

See page 9 for standard codification

Guide rollers **PFV**

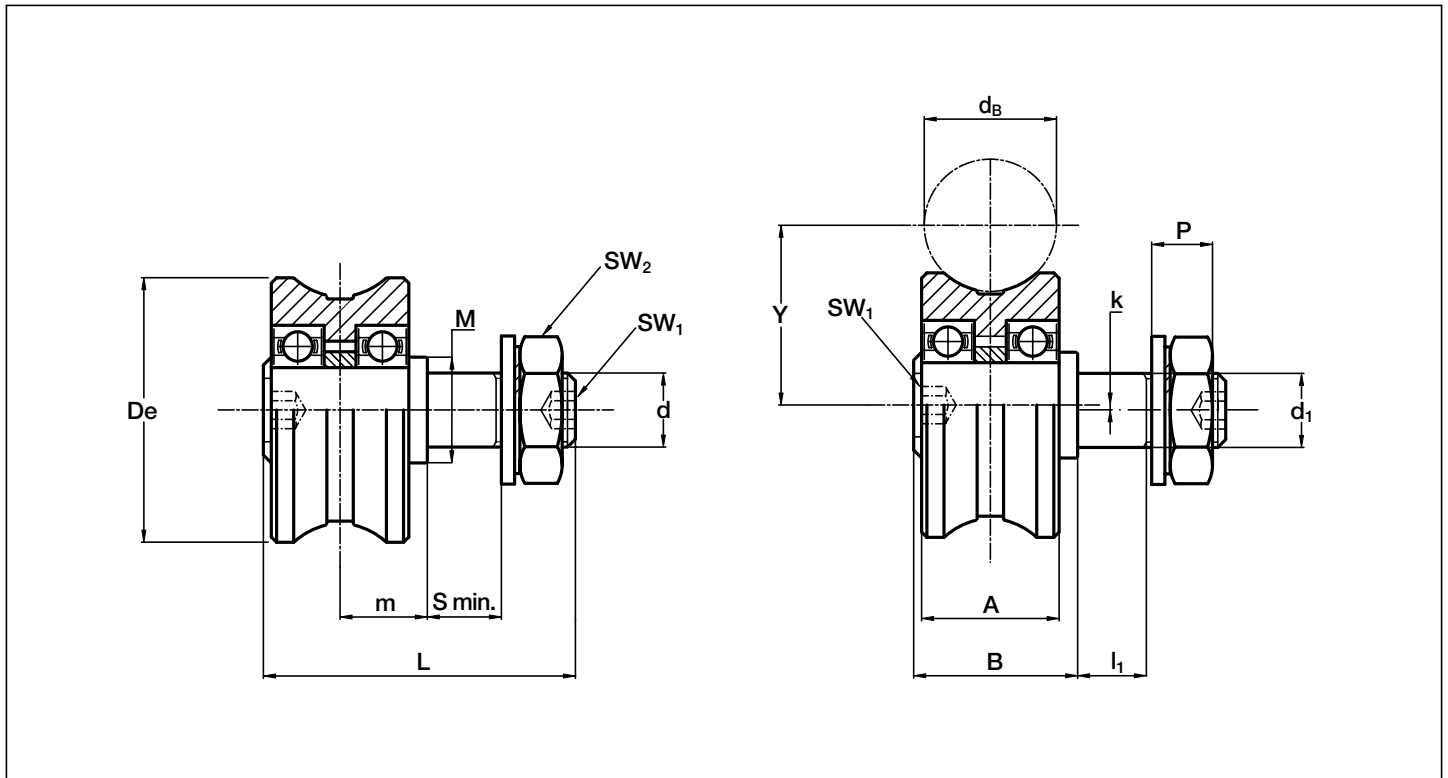
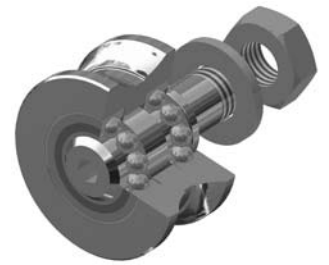

Type		Dimensions (mm)															Recommended pairings	
concentric	eccentric	De	d _B	d ₁ ⁽¹⁾	d	Y	m	S min.	P	L	A	B	I ₁	M	SW ₁	SW ₂		k
PFV 25.10	PFVR 25.10	25	10	8	M8x1.25	15.5	7.5	11	9	34.8	12	14.8	10	12	4	ch.13	0.75	C 10
PFV 35.16 ⁽³⁾	PFVR 35.16 ⁽³⁾	35	16	10	M10x1.25	23	12	12	10.7	45.3	18	22.3	11	15	4	ch.17	0.75	DC 16.80
PFV 35.18 ⁽³⁾	PFVR 35.18 ⁽³⁾	35	18	10	M10x1.25	24	12	12	10.7	45.3	18	22.3	11	15	4	ch.17	0.75	C 18/DC 18.65
PFV 43.22 ⁽³⁾	PFVR 43.22 ⁽³⁾	43	22	12	M12x1.5	29	14	13	12.5	52	23	27	12	18	5	ch.19	1	C 22
PFV 50.25 ⁽³⁾	PFVR 50.25 ⁽³⁾	50	25	14	M14x1.5	34	16.5	14	13.5	59	26	31	13	20	6	ch.22	1	C 25.95
PFV 60.30	PFVR 60.30	60	30	16	M16x1.5	41	19.5	17	14	69.5	31	36.5	16	30	8	ch.24	1	C 30

Type		Bearing rating (N)			Limit loads (N)		Life coefficients		Torque wrench ⁽²⁾ settings (Nm)	Weight (g)
		Dynamic C _w ⁽⁴⁾	Static		radial F _r	Axial F _a	X	Y		
			C _{or}	C _{oa}						
PFV 25.10	PFVR 25.10	1 850	1 080	200	1 740	450	1	4.4	8	42
PFV 35.16	PFVR 35.16	4 550	2 320	430	2 120	570	1	4.4	20	115
PFV 35.18	PFVR 35.18	4 570	2 320	430	2 120	570	1	4.4	20	113
PFV 43.22	PFVR 43.22	7 600	4 000	780	3 150	820	1	4	26	210
PFV 50.25	PFVR 50.25	8 800	4 800	940	4 240	1 100	1	4	44	335
PFV 60.30	PFVR 60.30	15 700	8 500	1 560	5 360	1 350	1	4.3	64	570

1) Housing bore tolerance: H7

2) The torque wrench settings are given for non-lubricated threads; for lubricated threads, multiply figure by 0.8

3) Available in stainless steel (suffix **NX**)

4) C_w basic load for 100 km

5) The guide rollers are complete with self-locking washers and hexagonal nut for fitting

6) Pressure angle α for load calculation: 64°

7) NBR seals RS type

Carriages **T4PFV**

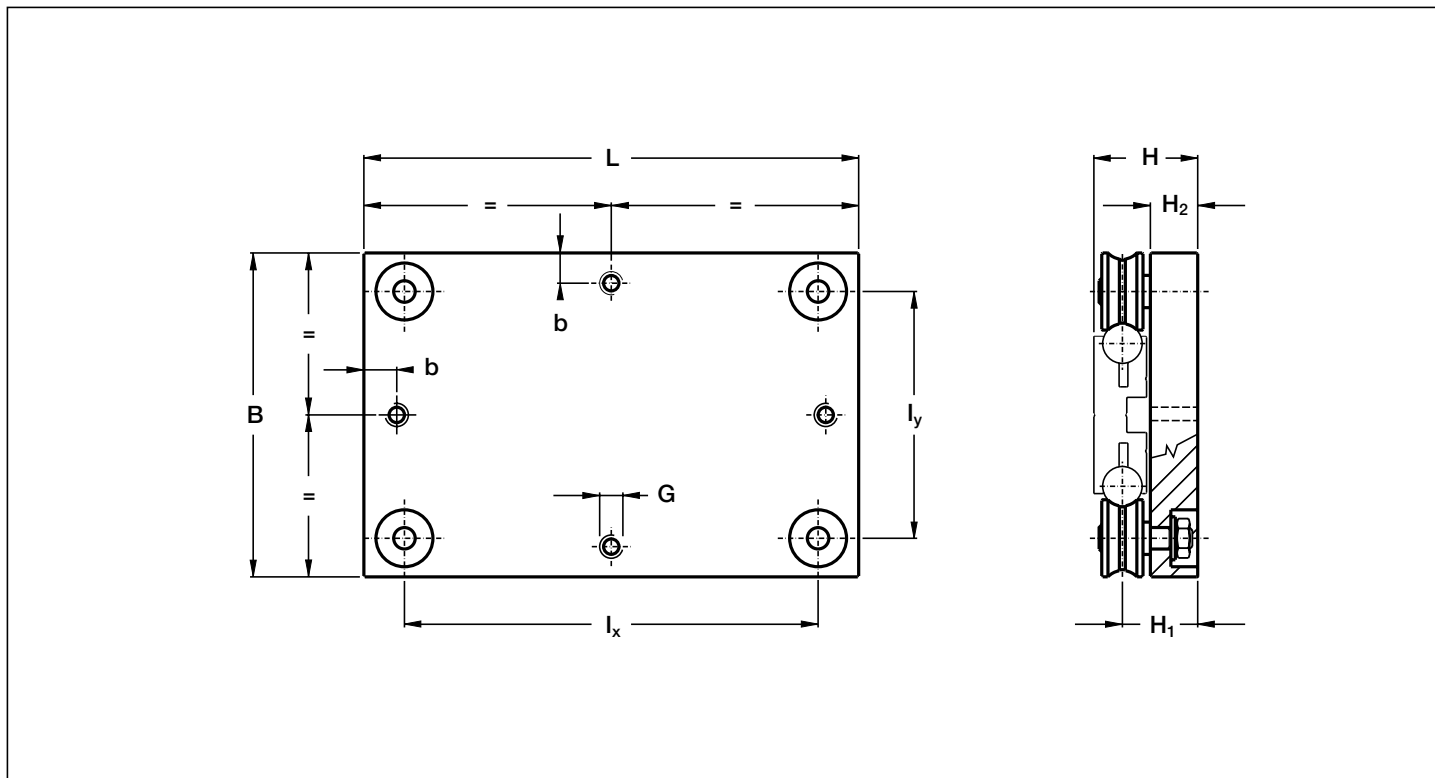

Type	Dimensions (mm)									Weight (kg)	Recommended pairings
	L	B	I _x	I _y	H	H ₁	H ₂	G	b		
T4PFV 35 16 165 ⁽¹⁾	165	165	126	126	50.5	36	24	M8	15	2.1	DC 16.80
T4PFV 35 16 250 ⁽¹⁾	250	165	211	126	50.5	36	24	M8	15	3.1	DC 16.80
T4PFV 35 18 150	150	150	113	113	49	36	24	M8	15	1.8	DC 18.65
T4PFV 35 18 250	250	150	213	113	49	36	24	M8	15	2.8	DC 18.65
T4PFV 50 25 220 ⁽¹⁾	220	220	163	163	63.5	45.5	29	M10	20	5	DC 25.95
T4PFV 50 25 300 ⁽¹⁾	300	220	243	163	63.5	45.5	29	M10	20	6.4	DC 25.95

1) Available with stainless steel guide rollers (**NX**)

2) Carriages are complete with guide rollers

3) Pressure angle α for load calculation: 64°

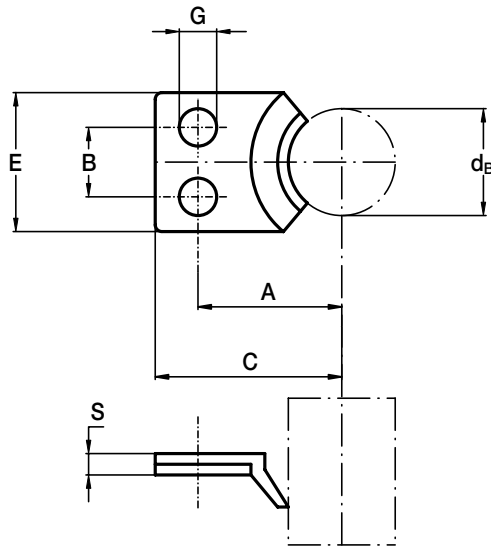
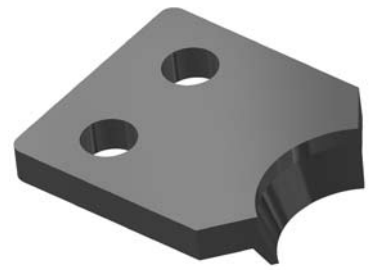

Type	Dimensions (mm)								Recommended pairings
	d_B	E	C	A	B	G	A	S	
NAID 010	10	13	17.5	13.5	6.5	3.5	12	3	C 10
NAID 016	16	20	26.5	20.5	10	4.5	18	3	DC 16.80
NAID 018	18	20	26.5	20.5	10	4.5	18	3	C 18/DC 18.65
NAID 022	22	24	30	24	14	4.5	23	3	C 22
NAID 025	25	28	37.5	30.5	18	4.5	26	3	C 25.95
NAID 030	30	32	45.5	37.5	20	5.5	31	3	C 30

Mounting Examples

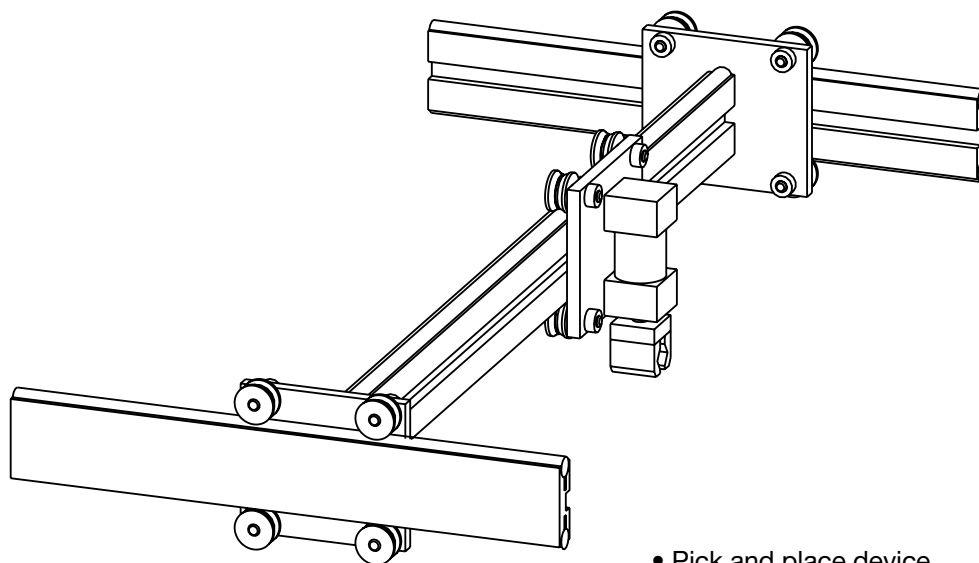

• Pick and place device

FWS, FWH System



NADELLA

Guide Rails FWS

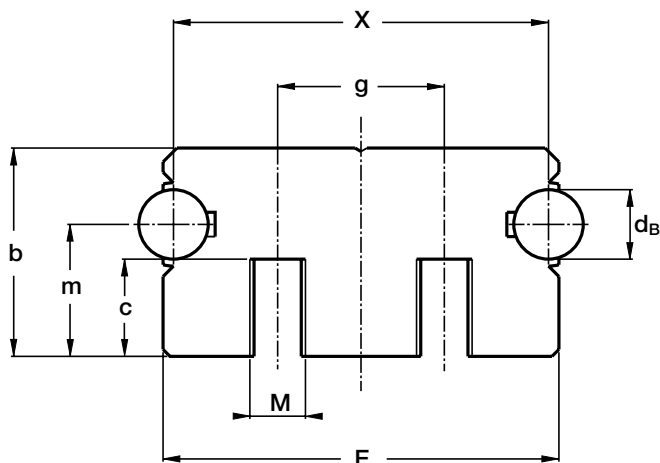

Type	Dimensions (mm)							
	d_B	X	M	g	E	b	m	c
FWS 22	6	34	M 5	16	36	20	14	10
FWS 32	8	42	M 6	20	45	25	17	12
FWS 40	10	54	M 8	24	57	30	19	14
FWS 52	12	66	M 10	32	69	36	24	18

single guide element L=4500 ⁽¹⁾

Type	Screw distance max.			Momentsof inertia ⁽²⁾ cm ⁴		Weight (kg/m)
	for 2 screw channels		for holes	J_x	J_y	
	Distance (mm)	Torque wrench settings (Nm)	Distance (mm)			
FWS 22	190	2	220	2.07	6.01	2
FWS 32	210	5	240	5.1	14.56	3.3
FWS 40	250	15	280	11.01	35.26	5
FWS 52	250	23	280	22.85	74.12	7.2

1) longer rails are supplied in sections with ground butt joints at the rods

2) Inertia value based on equivalent aluminium yield 70000 N/mm² including shafts

Hole layout

- finishes to drawing (**NZ**)
- without holes (**NF**)

Optional features

- ground one end (**R**)
- ground both ends (**RR**)
- Stainless steel shafts (**NX**)

Example of standard designation: **FWS32 S/1500/NF**

See page 9 for standard codification

Guide Rails FWH

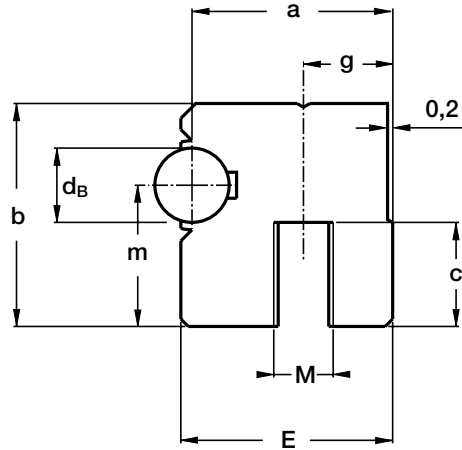
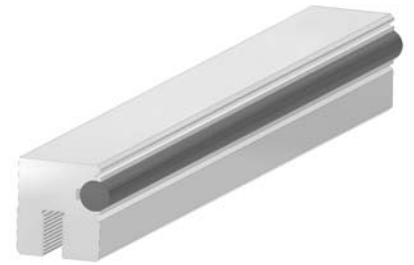

Type	Dimensions (mm)							
	d_B	a	M	g	E	b	m	c
FWH 22	6	17	M5	8	18	20	14	10
FWH 32	8	21	M5	10	22.5	25	17	12
FWH 40	10	27	M8	12	28.5	30	19	14
FWH 52	12	33	M10	16	34.5	36	24	18

Maximum length of single guide element L = 4 500 ⁽¹⁾

Type	Screw distance max.			Moments of inertia ⁽²⁾ cm ⁴		Weight (kg/m)
	for 1 screw channels		for holes	J_x	J_y	
	Distance (mm)	Torque wrench settings (Nm)	Distance (mm)			
FWH 22	70	2	120	1.02	0.83	1
FWH 32	60	5	130	2.55	2.05	1.6
FWH 40	97	15	150	5.71	4.75	2.5
FWH 52	120	23	150	10.12	11.85	3.6

1) longer rails are supplied in sections with ground butt joints

2) Inertia value based on equivalent aluminium yield 70000 N/mm² including shafts

Hole layout

- finishes to drawing (**NZ**)
- without holes (**NF**)

Optional features

- ground one end (**R**)
- ground both ends (**RR**)
- Stainless steel shafts (**NX**)

Example of standard designation: **FWS32 S/1500/NF**

See page 9 for standard codification

Guide Rollers **FR..EI**

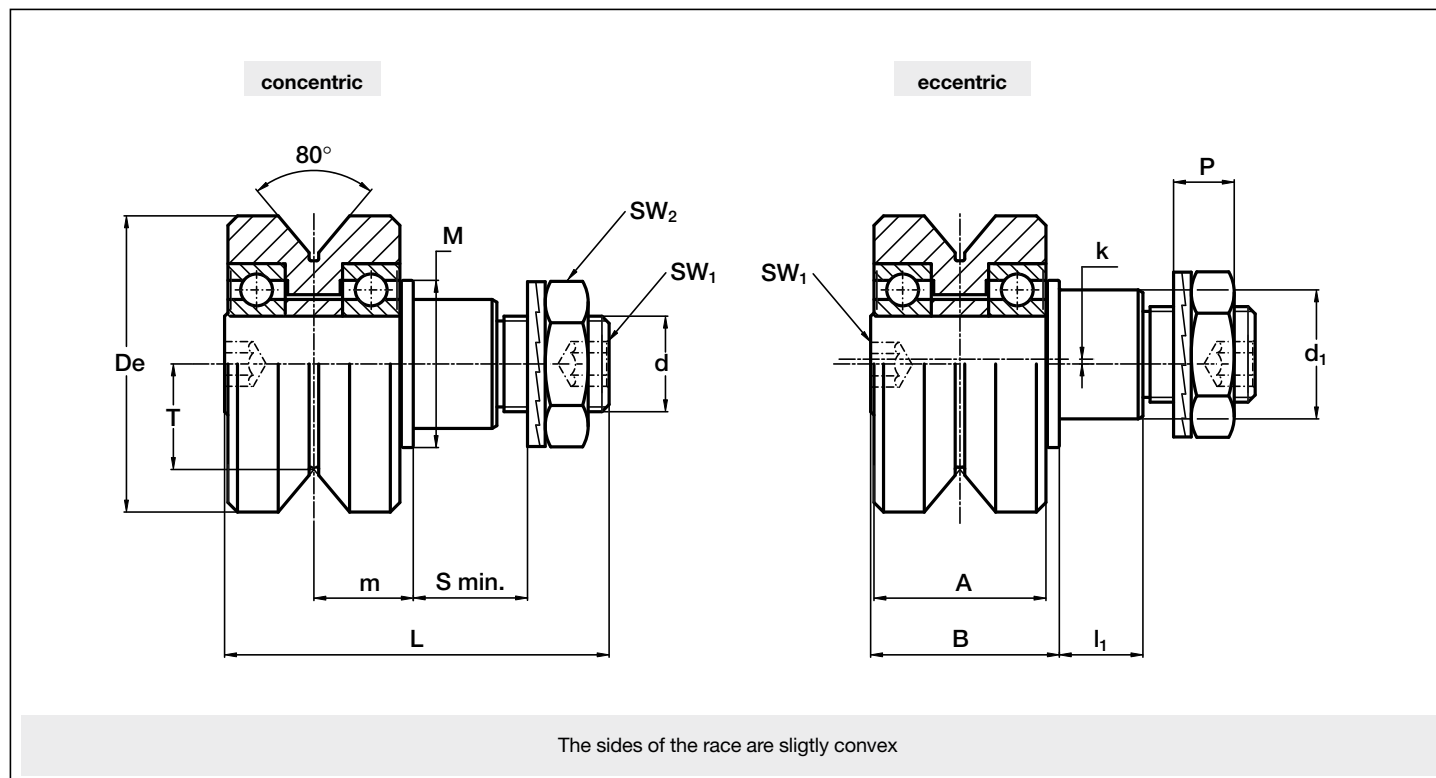

Type		Dimensions (mm)														
concentric	eccentric	De	d ₁ ⁽¹⁾	d	T	m	S min.	P	L	A	B	l ₁	M	SW ₁	SW ₂	k
FR 22 EI	FRR 22 EI	22	9	M 6 x 1	7.7	9.4	9	6.5	37	15	18.2	8	14	4	ch. 10	0.5
FR 32 EI	FRR 32 EI	32	14	M 10 x 1.25	11.8	12.6	12	8.5	50.5	21	24.5	11	20	4	ch. 16	1
FR 40 EI	FRR 40 EI	40	16	M 12 x 1.5	14.6	15.5	12	10.4	59.5	28	30.5	11	22	5	ch. 18	1
FR 52 EI	FRR 52 EI	52	21	M 16 x 1.5	19.1	19.8	15	11.4	69.5	32	36.5	14	28	6	ch. 24	1,5
FR 62 EI	FRR 62 EI	62	27	M 20 x 1.5	22.1	20.8	18.5	12.4	80.5	36	39.5	17.5	35	8	ch. 30	2

Type		Bearing rating (N)			Limit loads (N)		Life coefficients		Torque wrench ⁽²⁾ settings (Nm)	Weight (g)
		Dynamic	Static							
			C _w ⁽⁴⁾	radial C _{or}	axial C _{oa}	radial F _r	axial F _a	X		
FR 22 EI	FRR 22 EI	1 800	1 080	350	1 700	720	1	2.20	3	45
FR 32 EI	FRR 32 EI	4 400	2 330	750	1 200	500	1	2.92	20	130
FR 40 EI	FRR 40 EI	7 350	4 000	1 300	3 000	1 300	1	2.75	26	260
FR 52 EI	FRR 52 EI	9 500	5 500	1 750	7 500	3 000	1	2.96	64	510
FR 62 EI	FRR 62 EI	15 500	8 500	2 750	10 900	4 200	1	3.07	120	820

- 1) Housing bore tolerance: H7
- 2) The torque wrench settings are given for non-lubricated threads; for lubricated threads, multiply figure by 0.8
- 3) On request, the guide rollers can be supplied in AISI 440 stainless steel (suffix **NX**)
- 4) C_w basic load for 100 km
- 5) The guide rollers are complete with self-locking washers and hexagonal nut (DIN 439B) for fitting
- 6) Pressure angle α for load calculation: 40°
- 7) NBR seals RS type

Guide Rollers **FR**

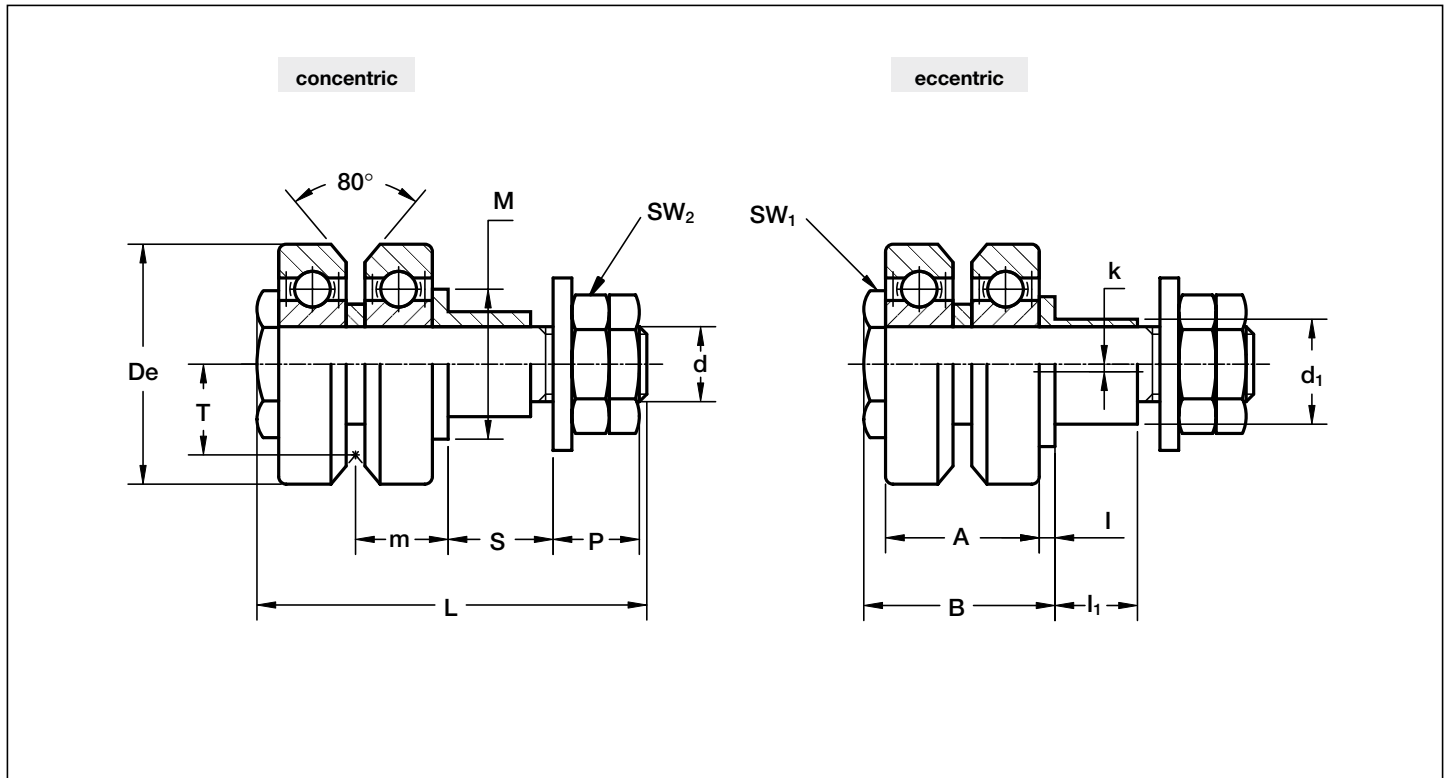

Type		Dimensions (mm)															
concentric	eccentric	De	d ₁ ⁽¹⁾	d	T	m	S min.	P	L	A	B	I ₁	I	M	SW ₁	SW ₂	k
FR 22	FRR 22	22	9	M 6 x 1	8.0	9.2	9	7.7	39	13.9	19.5	8	2.2	14	10	10	0.5
FR 32	FRR 32	32	14	M 10 x 1.25	12.1	12.4	12	11.5	52	20.5	25.5	11	2.1	20	17	17	1
FR 40	FRR 40	40	16	M 12 x 1.5	14.6	15.5	12	13.5	60	25.0	31.0	11	3.0	22	22	19	1
FR 52	FRR 52	52	21	M 16 x 1.5	19.1	19.8	15	17	73	32.0	40.0	14	3.8	28	27	24	1,5

Type		Bearing rating (N)			Limit loads (N) shaft		Life coefficients		Torque wrench ⁽²⁾ settings (Nm)	Weight (g) ⁽³⁾
		Dynamic C _w ⁽⁴⁾	Static		radial F _r	axial F _a	X	Y		
			radial C _{or}	axial C _{oa}						
FR 22	FRR 22	700	415	105	800	380	1	0.593	3	43
FR 32	FRR 32	1 480	830	210	2 770	1 240	1	0.593	20	132
FR 40	FRR 40	2 440	1 300	325	3 830	1 720	1	0.593	26	235
FR 52	FRR 52	4 130	2 120	530	7 100	3 150	1	0.593	64	490

1) Housing bore tolerance: H7; maximum angular deviation of drilled axis to rolling flat +/- 5'

2) The torque wrench settings are given for non-lubricated threads; for lubricated threads, multiply figure by 0.8

3) Weight without fittings

4) C_w basic load for 100 km

5) The guide rollers are completed with conical spring washer, nut and counter nut

6) Pressure angle α for load calculation: 40°

7) NBR seals RS type

Guide Rollers **FR..AS**

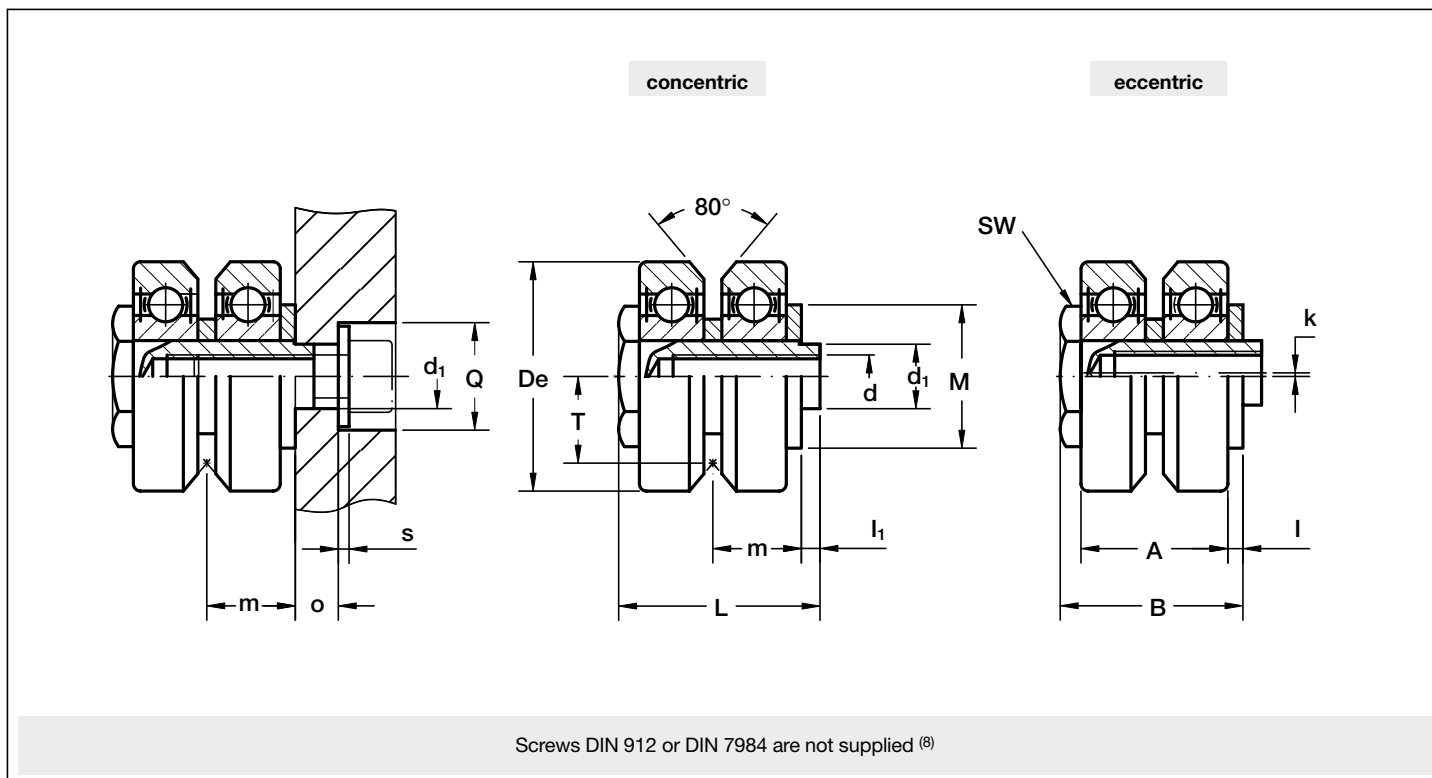

Type		Dimensions (mm)															
concentric	eccentric	De	d ₁ ⁽¹⁾	d ⁽²⁾	T	m	L	A	B	l ₁	I	M	SW	o	Q	s	k
FR 22 AS	FRR 22 AS	22	6	M 5	8.0	9.2	21.5	13.9	19.5	2.0	2.2	14	10	4.5	10	0	0.5
FR 32-1 AS	FRR 32-1 AS	32	9	M 6	12.1	12.4	28.1	20.5	25.5	2.6	2.1	20	17	6.0	15	1.5 ⁽⁵⁾	0.5
FR 40-1 AS	FRR 40-1 AS	40	13	M 8	14.6	15.5	33.5	25.0	31.0	2.5	3.0	25	22	6.5	20	2 ⁽⁵⁾	1.0
FR 52-1 AS	FRR 52-1 AS	52	16	M 10	19.1	19.8	43.2	32.0	40.0	3.2	3.8	32	27	8.0	24	2.5 ⁽⁵⁾	2.0

Type		Bearing rating (N)			Limit loads (N) shaft		Life coefficients		Weight (g) ⁽³⁾
		Dynamic	Static		radial F _r	axial F _a	X	Y	
		C _w ⁽⁴⁾	radial C _{or}	axial C _{oa}					
FR 22 AS	FRR 22 AS	700	415	105	470	210	1	0.593	32
FR 32-1 AS	FRR 32-1 AS	1 480	830	210	1 590	710	1	0.593	93
FR 40-1 AS	FRR 40-1 AS	2 440	1 300	325	4 040	1 790	1	0.593	169
FR 52-1 AS	FRR 52-1 AS	4 130	2 120	530	5 830	2 560	1	0.593	365

1) Housing bore tolerance H7 maximum angular deviation of drilled axis to rolling flat +/- 5'

2) Safety thread SPIRALOCK, for more information contact our Technical department

3) Weight without fittings

4) C_w basic load for 100 km

5) The guide rollers are completed with washer DIN 134

6) Pressure angle α for load calculation: 40°

7) NBR seals RS type

8) Length of screws: min = d+o+s; max = m+o+s

Guide Rollers **FR..AZ**

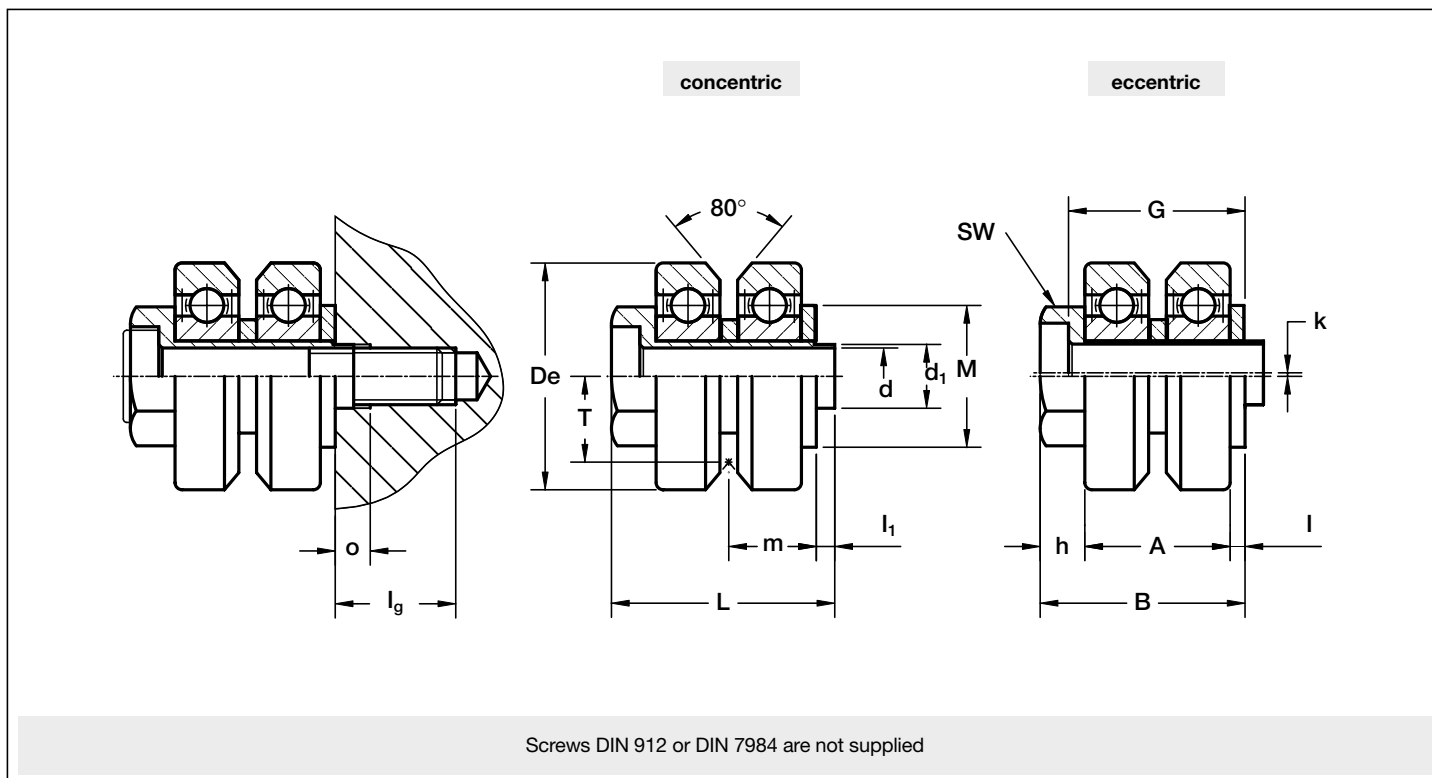

Type		Dimensions (mm)																
concentric	eccentric	De	d ₁ ⁽¹⁾	d	T	m	L	A	B	l ₁	l	h ⁽⁵⁾	M	SW	G	o	l _g ⁽²⁾	k
FR 22 AZ	FRR 22 AZ	22	6	5.1	8.0	9.2	23.5	13.9	21.5	2.0	2.2	5.4	14	10	18.5	4.0	13	0.5
FR 32 AZ	FRR 32 AZ	32	9	8.1	12.1	12.4	31.5	20.5	28.9	2.6	2.1	6.3	20	17	24.9	5.0	17	0.5
FR 40 AZ	FRR 40 AZ	40	13	12.1	14.6	15.5	39.0	25.0	36.5	2.5	3.0	8.5	25	24	30.5	5.0	26	1.0
FR 52 AZ	FRR 52 AZ	52	16	14.1	19.1	19.8	49.5	32.0	46.3	3.2	3.8	10.5	32	27	39.3	5.5	27	2.0

Type		Bearing rating (N)			Limit loads (N) shaft		Life coefficients		Weight (g)	Required screws ⁽³⁾ e.g. DIN7984
		Dynamic	Static		radial F _r	axial F _a	X	Y		
		C _w ⁽⁴⁾	radial C _{or}	axial C _{oa}						
FR 22 AZ	FRR 22 AZ	700	415	105	470	210	1	0.593	30	M 5 x 30
FR 32 AZ	FRR 32 AZ	1 480	830	210	1 590	710	1	0.593	91	M 8 x 40
FR 40 AZ	FRR 40 AZ	2 440	1 300	325	4 040	1 790	1	0.593	169	M 12 x 50
FR 52 AZ	FRR 52 AZ	4 130	2 120	530	5 830	2 560	1	0.593	357	M 14 x 60

1) Housing bore tolerance: H7 maximum angular deviation of drilled axis to rolling flat ±5'

2) Min. thread length for steel

Recommended screwed depth in steel = 1*d

In cast iron e.g. grey cast iron = 1,25*d

In aluminium = 2*d

3) Min. length of required screws for dimension d to mount into steel

4) C_w basic load for 100 km

5) Dimension h plus screw head must be maintained free when using these guide rollers with FWS or FWH guide rails

6) Pressure angle α for load calculation: 40°

7) NBR seals RS type

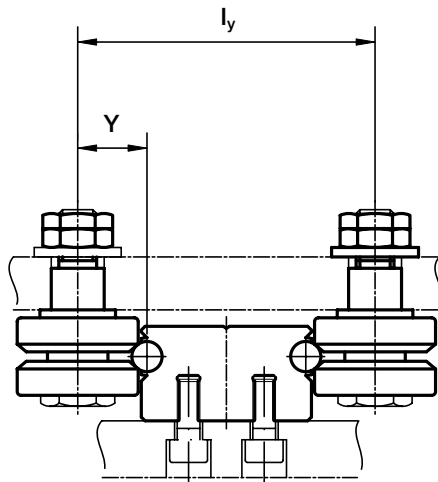

Type	Roller type FR/FRR, FR/FRR..AS/..AZ, FR/FRR..-2-..-2AB		Roller type FR/FRR...EI		Roller type FRO/FROR..-2/-2 AB FRLOK..FRLOR/FRLO	
	Y	l_y	Y	l_y	Y	l_y
FWS 22	12.7	59.4	12.4	58.8	13.0	60.0
FWS 32	18.3	78.6	18.0	78.0	18.5	79.0
FWS 40	22.4	98.8	22.4	98.8	22.9	99.8
FWS 52	28.4	122.8	28.4	122.8	29.0	124.0

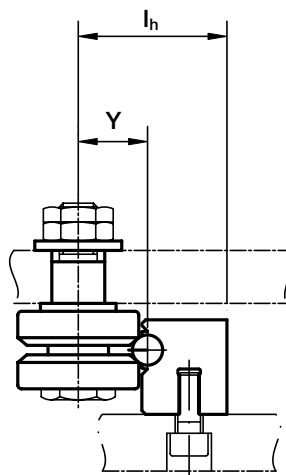

Type	Roller type FR/FRR, FR/FRR..AS/..AZ, FR/FRR..-2-..-2AB		Roller type FR/FRR...EI		Roller type FRO/FROR..-2/-2 AB FRLOK..FRLOR/FRLO	
	Y	l_h	Y	l_h	Y	l_h
FWH 22	12.7	29.7	12.4	29.4	13.0	30.0
FWH 32	18.3	39.3	18.0	39.0	18.5	39.5
FWH 40	22.4	49.4	22.4	49.4	22.9	49.9
FWH 52	28.4	61.4	28.4	61.4	29.0	62.0

The guide roller size has to match the rail size: i.e. guide roller FR32 with guide rails FW32

Glue dispensing machine

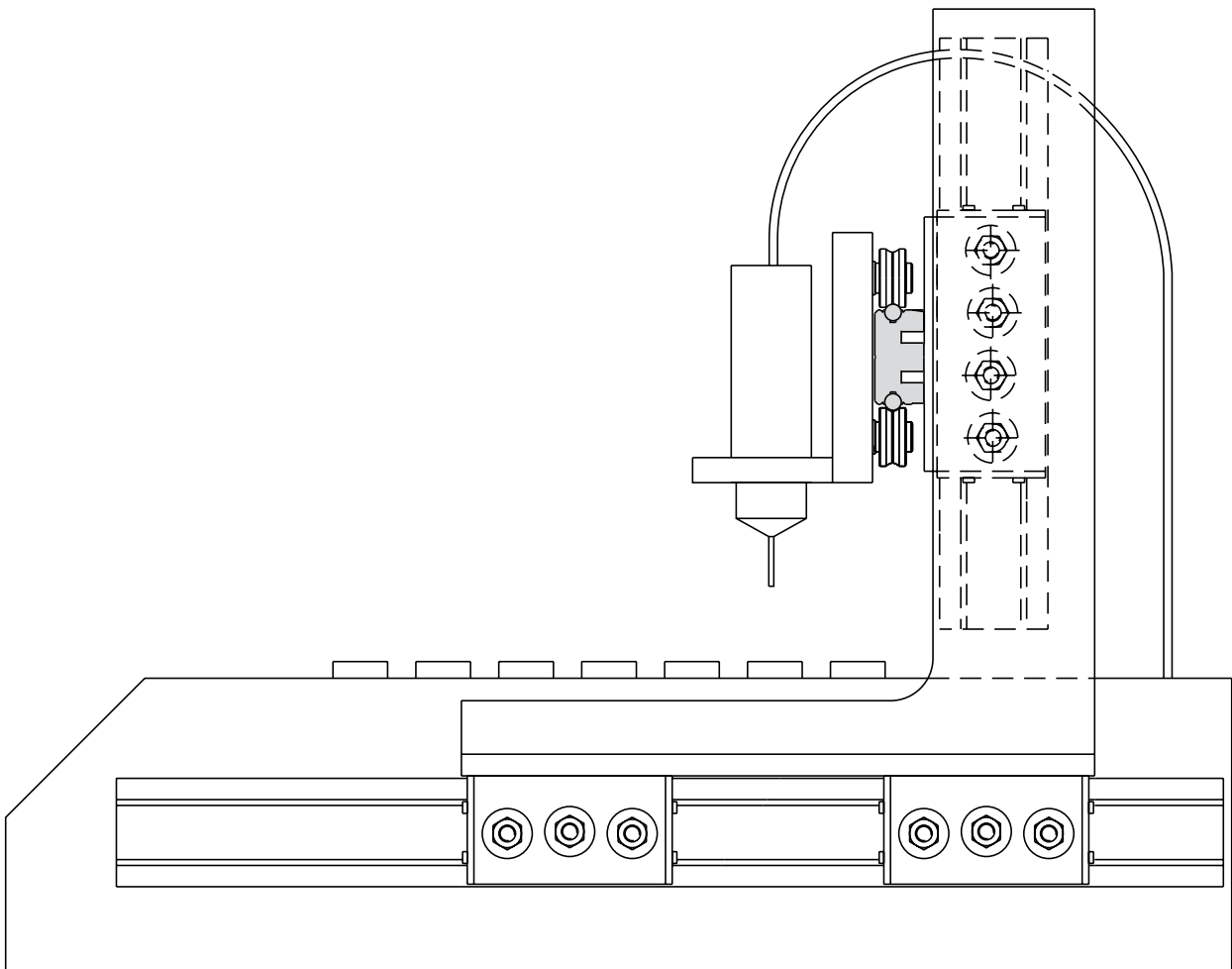

LM system



NADELLA

System

LM system is based on rail, guide rollers and carriages to provide a complete guiding system.

Guide rails and rollers can be used as single elements. In most cases the application is based on standard carriages and cursors.

Referring to the axis system below, the load capacities are tabulated as follows:

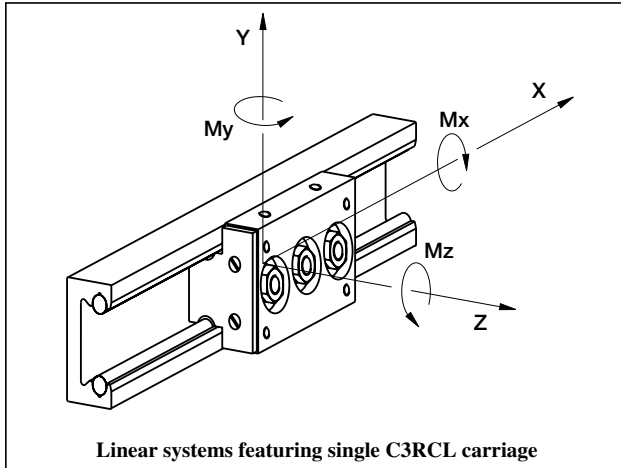

MAX LOAD ON SINGLE CARRIAGE

The following table shows the maximum load that can be applied on a single carriage.

Guide	Carriage	Fy N	Fz N	Mx Nm	My Nm	Mz Nm
LM 30	C3 RCL 17 06 065	1000*	330	3,5	5,8	10
	C4 RCL 17 06 085	1000	660	7	11	20
LM 40	C3 RCL 24 06 085	1810*	520	7,6	15	26
	C4 RCL 24 06 114	1810	1040	15	25	52
LM 65	C3 RCL 35 10 115	4160*	1200	26	45	78
	C4 RCL 35 10 152	4160	2400	50	75	155
LM 120	T4 RCL 35 10 150	4160	2400	110	120	200
	T4 RCL 35 10 220	4160	2400	110	200	350
	T4 RCP 42 10 150	5250	3030	140	150	260
	T4 RCP 42 10 220	5250	3030	140	250	440
LM 180	T4 PFV 43 22 180	6300	3120	185	200	400
	T4 PFV 43 22 280	6300	3120	185	350	715

* Fy directed to load the two concentric guide rollers

The maximum load is based on the guide roller data (stud and bearing strength) and on maximum contact pressure between rail and roller of 1250 N/mm². Loading is considered to be acting in a single plane or axis only.

BASIC DYNAMIC LOAD OF SINGLE CARRIAGE

The following table shows the nominal load that corresponds to a nominal life of the bearing at 100 km.

The nominal carriage life can be estimated from the standard bearing formula.

$$L_{10} = (C_i/P_i)^3 \times 100 \text{ km}$$

C_i and P_i are the basic capacity and load applied for a specific direction.

Guide	Carriage	Cy N	Cz N	CMx Nm	CMy Nm	CMz Nm
LM 30	C3 RCL 17 06 065	3000*	830	9	16	30
	C4 RCL 17 06 085	3000	1670	18	26	60
LM 40	C3 RCL 24 06 085	8400*	2340	34	67	122
	C4 RCL 24 06 114	8400	4670	68	110	244
LM 65	C3 RCL 35 10 115	15800*	4050	86	152	296
	C4 RCL 35 10 152	15800	8110	172	250	593
LM 120	T4 RCL 35 10 150	15800	8110	370	400	780
	T4 RCL 35 10 220	15800	8110	370	685	1335
	T4 RCP 42 10 150	24000	14130	650	700	1190
	T4 RCP 42 10 220	24000	14130	650	1195	2030
LM 180	T4 PFV 43 22 180	15190	5300	320	335	965
	T4 PFV 43 22 280	15190	5300	320	600	1725

* Fy directed to load the two concentric guide rollers

Calculation example: four carriages C3RCL 35 10 115 platform

The common configuration is shown in the here following sketch:

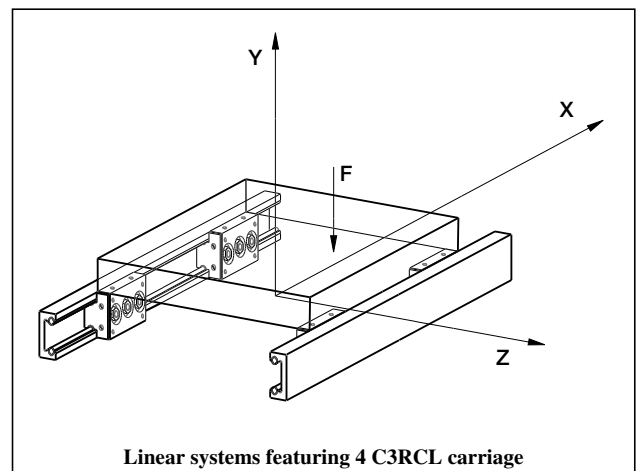

The platform moves along the two guide rails and has a load of "F" acting at 100 mm and 50 mm from the carriage centre.

Data:

guide LM 65 and cursors C3RCL3510115

$$I_x = 400 \text{ mm} \quad I_z = 300 \text{ mm}$$

$$F = 6.000 \text{ N} \quad X_F = 100 \text{ mm} \quad Z_F = 50 \text{ mm}$$

In this configuration the load on the most heavily loaded carriage is P_y and can be calculated using the following formula:

$$P = \frac{F}{4} + \frac{F \cdot X_F}{2 \cdot I_x} + \frac{F \cdot Z_F}{2 \cdot I_z} = 2750 \text{ N}$$

The load F_y shown in the "max loads" table is 4.160N (carriages mounted with eccentric roller on top), so the system is validated against breakage.

To estimate the system life we proceed as follows: from the nominal life table C_y = 15.800 N

$$L_{10} = (15.800/2.750)^3 \times 100 = 18.900 \text{ km}$$

Important note: to reach this value it is important to lubricate the rail, otherwise fretting corrosion between rail and roller can reduce the expected life.

Auto-aligning

Systems

Auto-aligning systems are assembled with guide rollers RAL type on LM system carriages tables.

The guide rollers RAL type allows axial displacement of the roller on the pin. An “O” ring retains the roller in position during the mounting.

Auto-aligning systems compensate for opposite rail misalignment errors. They are useful for mounting inaccurately aligned structures or those structures subject to flexure.

C3RAL C4RAL T4RAL

Is used to compensate for D_x misalignment between opposite rails. The table or carriage with all guide rollers RAL/RALR type can move towards or away from the rail. Type RAL provides radial support only. Axial load, transverse to the direction of travel, is reacted by carriage type RCL on the opposite rail.

C3RYL C4RYL T4RYL

Rail misalignment D_y requires the ability for both carriages to rotate. The table or carriage RYL type, with guide rollers RCL/RCP in contact with a steel shaft of the LM rail and guide rollers RALR type in contact with the opposite shaft, allows carriage rotation ensuring at the same time the transverse direction control.

The maximum D_y value is dependent on the distance between the rails and the tabulated maximum angle ‘ α ’ for that carriage.

Note: RYL carriage axial load capability is lower than the same size RCL/RCP carriage.

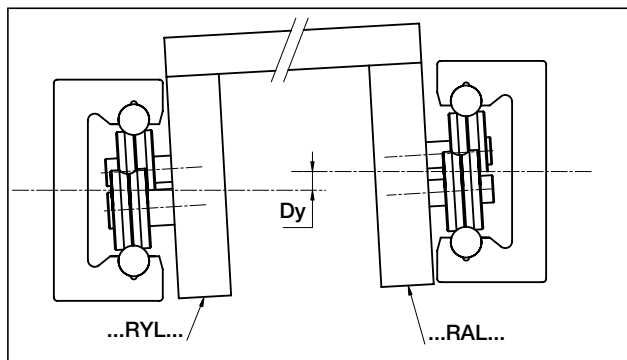
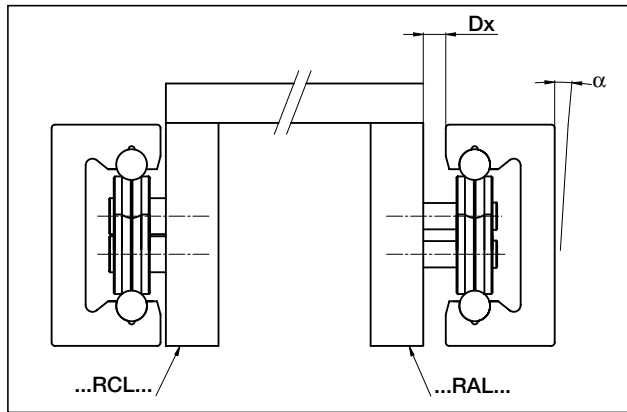
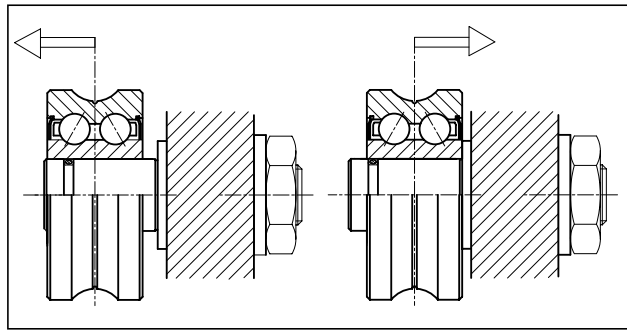

Max transverse moving allowed by auto-aligning tables and carriages

Carriage code (1)		α max (°)	S max (mm)	H nominal (mm)	Rail
C3RAL 17 06 065	C4RAL 17 06 085	1	0.8	27.5	LM 30
C3RYL 17 06 065	C4RYL 17 06 085	1	-		
C3RAL 24 06 085	C4RAL 24 06 114	1	1	35.7	LM 40
C3RYL 24 06 085	C4RYL 24 06 114	1	-		
C3RAL 35 10 115	C4RAL 35 10 152	1	1	58	LM 65
C3RYL 35 10 115	C4RYL 35 10 152	1	-		
T4RAL 35 10 150	T4RAL 35 10 220	0.3	1	58.5	LM 120
T4RYL 35 10 150	T4RYL 35 10 220	0.3	-		
T4RAL 42 10 150	T4RAL 42 10 220	0.75	1.5	65.5	
T4RYL 42 10 150	T4RYL 42 10 220	0.75	-		

1) See light load systems Nadella catalogue for table and carriage dimensions.

2) Variations of dimension H exceeding $\pm s$ can compromise bearing axial moving and decrease the roller limit load, Fr.

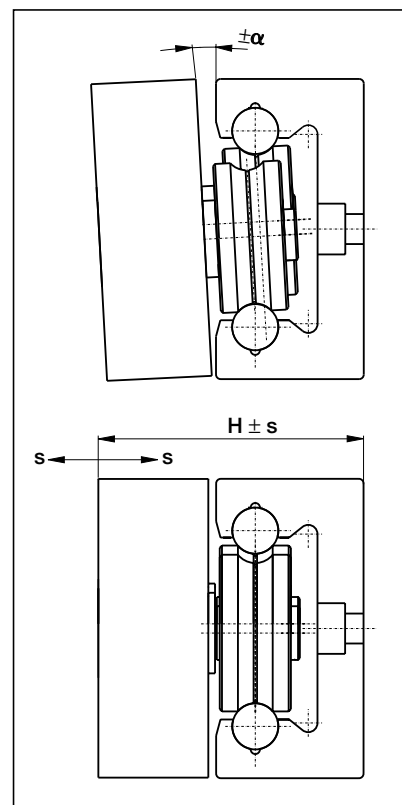

Guide Rails LM

NEW Now available with stainless steel shafts

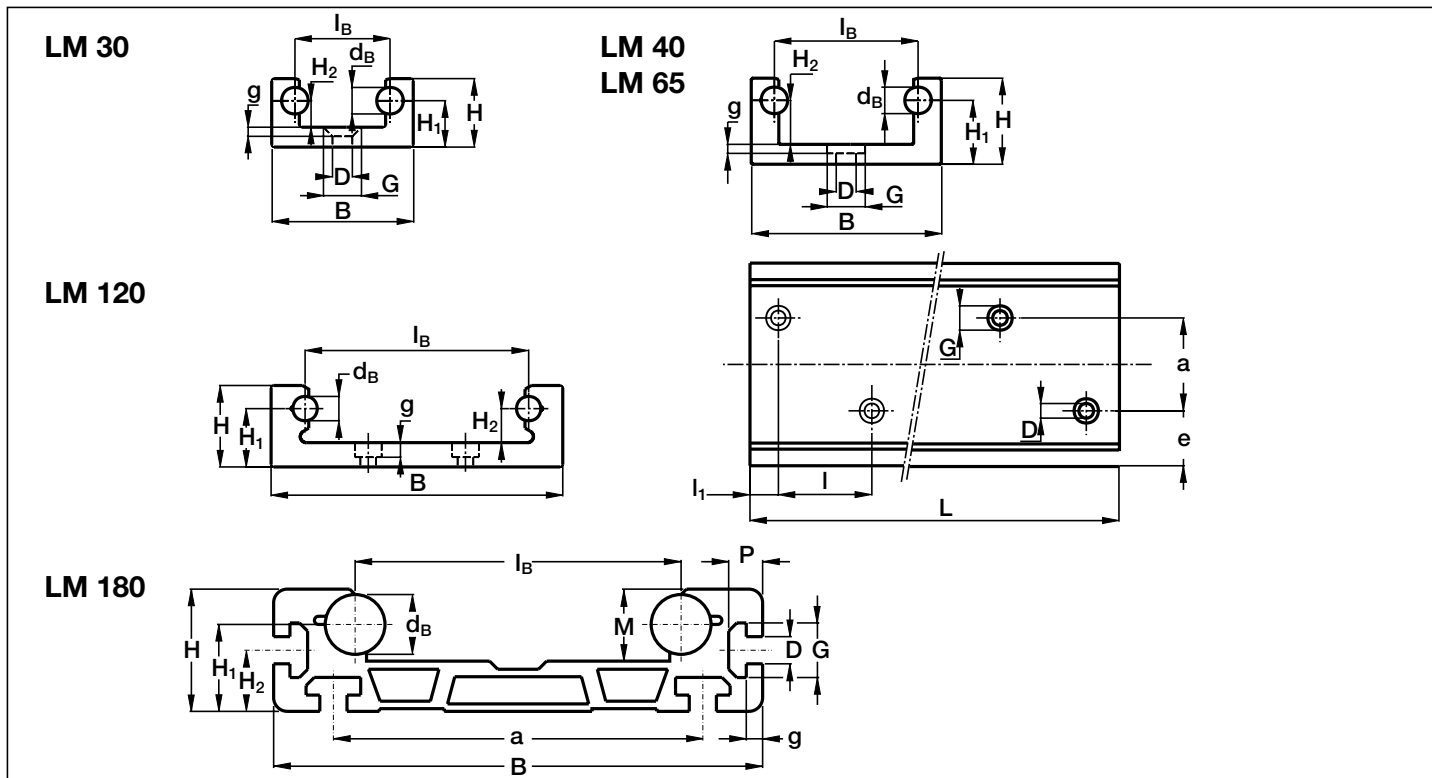

Type	Dimensions (mm)															Moments of inertia ⁽²⁾ (cm ⁴)		Weight (kg/m)	L ⁽¹⁾ max (mm)
	d _B	l _B	B	H	H ₁	H ₂	M	D	G	g	a	e	P	l	l ₁	J _x	J _y		
LM 30 ⁽⁴⁾	6	21.5	32	15.5	10.5	6	11	4.5	9.5	2.5	-	16	-	80	40	0.5	3	1.1	5 000
LM 40 ⁽⁴⁾	6	29	42	20	14	8	14	4.5	8	4	-	21	-	100	50	1.2	8.8	1.5	5 000
LM 65 ⁽⁴⁾	10	42.5	65	32	23.5	13.5	22	6.5	11	6	-	32.5	-	100	50	8.8	54.9	4.1	6 000
LM 120 ⁽⁴⁾	10	92	120	33.5	24	14	23.5	6.5	11	6	40	40	-	100	50	14.8	311.6	6	6 000
LM 180 ⁽³⁾	22	120	180	45	32	22.5	26.5	10	20.1	6	136	-	12.5	-	-	53.3	1 096.6	13.1	6 000

1) longer rails are supplied in sections with ground butt joints and, on request, with pin connection

2) Inertia value based on equivalent aluminium yield 70000 N/mm²

3) available with hollow shafts

4) available with stainless steel shafts (suffix NX)

Hole layout

- holes according to catalogue (**SB**)
- finishes to drawing (**NZ**)
- without holes (**NF**)

Optional features

- ground one end (**R**)
- ground both ends (**RR**)
- Chromium plated shafts (**CH**)
- Stainless steel shafts (**NX**)

Example of standard designation: **LM 40/1720/NF**

See page 9 for standard codification

Guide Rollers RCL, RCP, PFV

NEW Now available in stainless steel

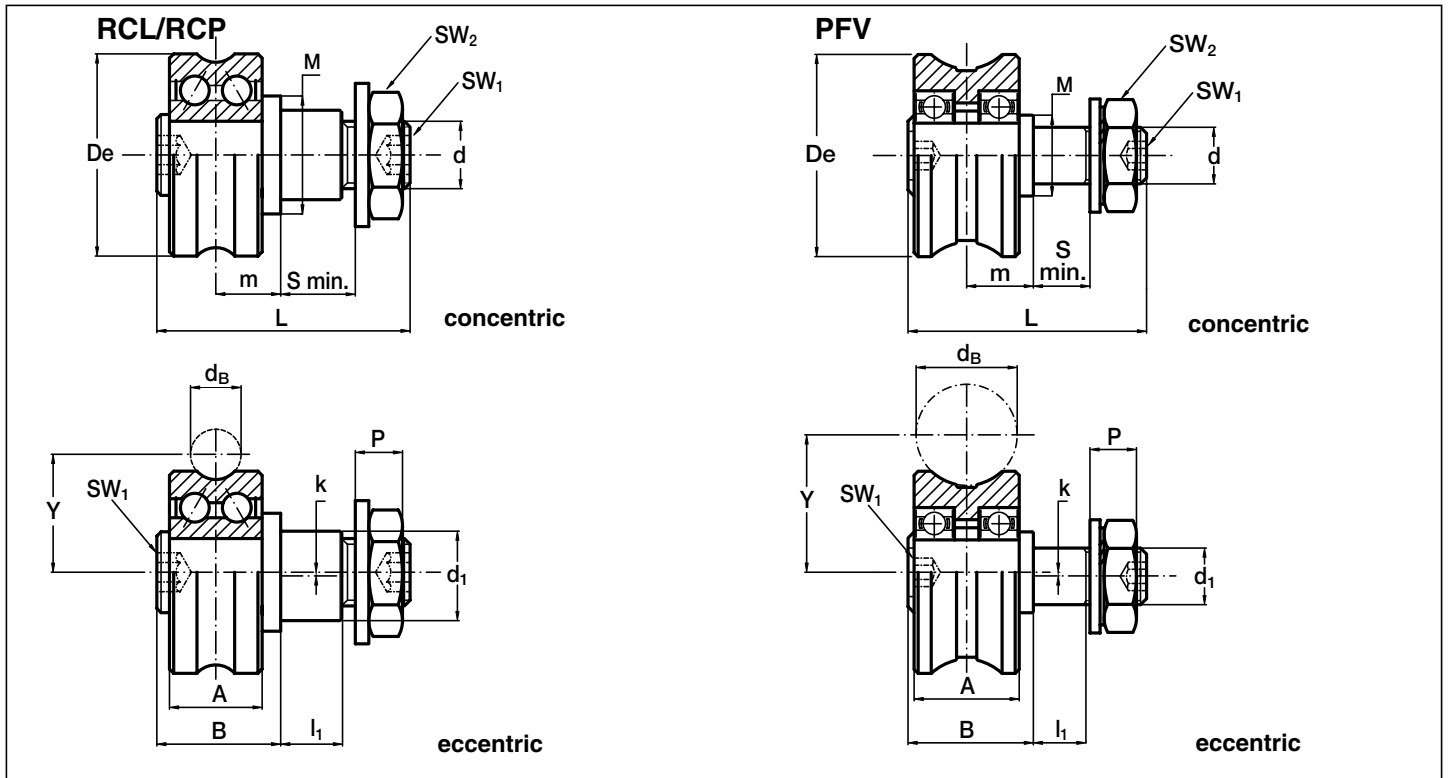

Type		Dimensions (mm)															Suggested combination		
concentric	eccentric	De	d _B	d ₁ ⁽¹⁾ conc.	d ₁ ⁽¹⁾ ecc.	d	Y	m	S min.	P	L	A	B	l ₁	M	SW ₁		SW ₂	k
RCL 17.06 ⁽³⁾	RCLR 17.06 ⁽³⁾	17	6	5	6.5	M 5x0.8	10.5	6	6	3.7	21	7	11	5.5	9	2.5	ch. 8	0.25	LM 30
RCL 24.06 ⁽³⁾	RCLR 24.06 ⁽³⁾	24	6	8	11	M 8x1.25	14	7.7	7	5.6	28.2	11	14.7	6.5	14	4	ch. 13	0.5	LM 40
RCL 35.10 ⁽³⁾	RCLR 35.10 ⁽³⁾	35	10	10	10	M10x1.25	20.65	10.5	14	7	45	15.9	22.5	13	18	5	ch. 17	0.75	LM 65
RCP 42.10	RCPR 42.10	42	10	17	17	M12x1.25	24	12.5	12	9.5	50	19	24.5	11	25	6	ch. 19	0.75	LM 120
PFV 43.22 ⁽³⁾	PFVR 43.22 ⁽³⁾	43	22	12	12	M12x1.5	29	14	13	12.5	52	23	27	12	18	5	ch. 19	1	LM 180

Type		Bearing rating (N)			Limit loads (N)		Life coefficients				Torque wrench ⁽²⁾ settings (Nm)	Weight (g)
		Dynamic C _w ⁽⁴⁾	Static				Pa/Pr ≤ 0.37		Pa/Pr > 0.37			
			radial C _{or}	axial C _{oa}	radial F _r	axial F _a	X	Y	X	Y		
RCL 17.06	RCLR 17.06	1 500	840	350	530	260	1	1.37	0.5	2.73	1.8	20
RCL 24.06	RCLR 24.06	4 200	2 300	1 000	1 600	830	1	1.37	0.5	2.73	8	40
RCL 35.10	RCLR 35.10	7 900	5 100	1 500	2 400	1 100	1	1.67	0.5	3.03	20	130
RCP 42.10	RCPR 42.10	12 000	7 100	2 100	4 300	1 160	1	1.17	0.5	2.53	24	185
PFV 43.22	PFVR 43.22	7 600	4 000	780	3 150	820	1	4	1	4	24	205

1) Housing bore tolerance: H7

2) The torque wrench settings are given for non-lubricated threads; for lubricated threads, multiply figure by 0.8

3) Available in stainless steel (suffix **NX**) with RS seals type

4) C_w basic load for 100 km

5) The guide rollers are complete with self-locking washers and hexagonal nut for fitting

6) Pressure angle α for load calculation: 60°

7) Standard seals ZZ type

Guide Rollers RAL

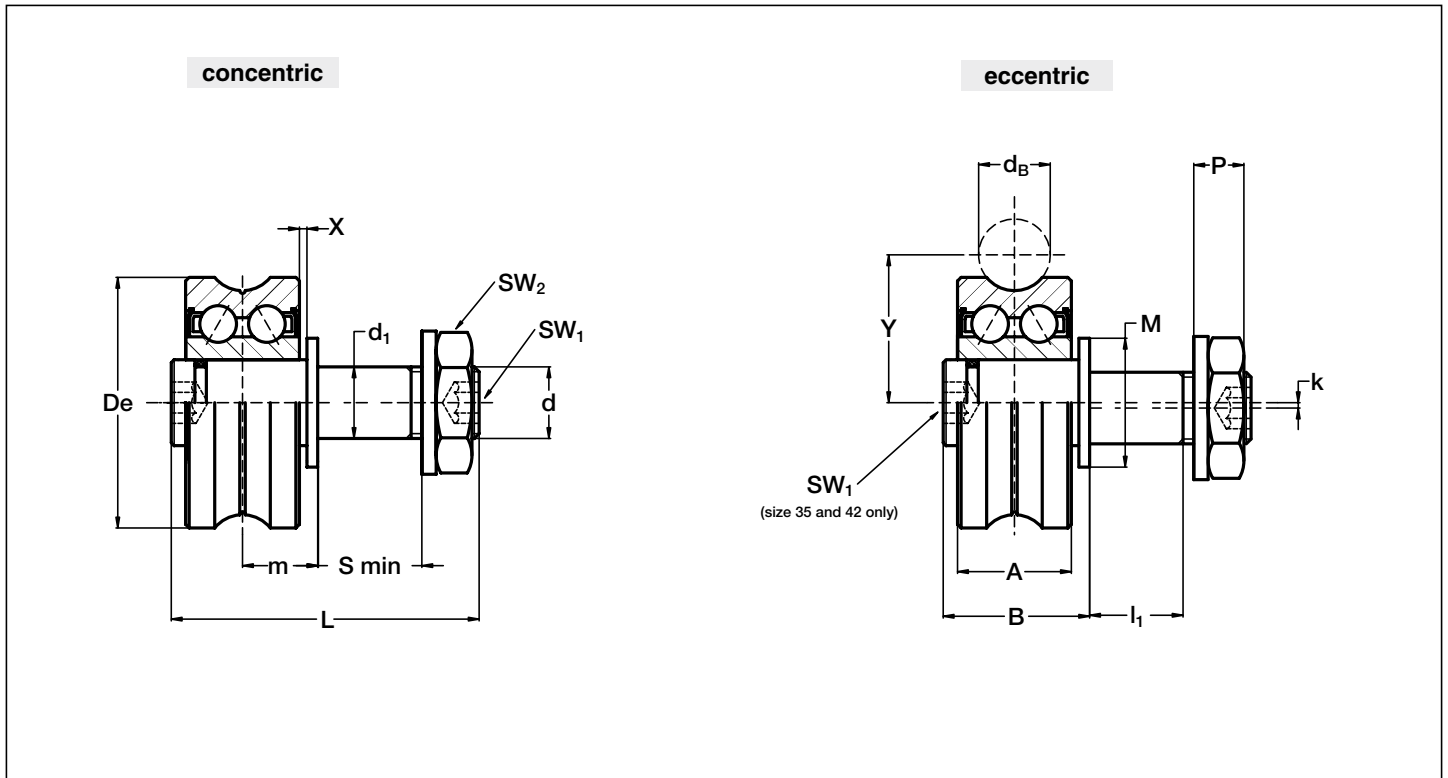
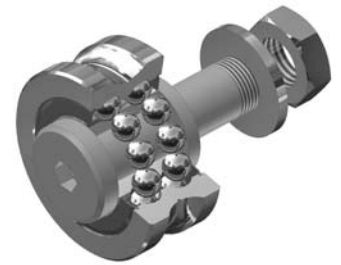

Type		Dimensions (mm)																		Suggested combination
concentric	eccentric	De	dB	d ₁ ⁽¹⁾ conc.	d ₁ ⁽¹⁾ ecc.	d	Y	m	S min.	P	L	A	B	X ⁽⁵⁾	I ₁	M	SW ₁	SW ₂	k	
RAL 17.06	RALR 17.06	17	6	5	6.5	M 5x0.8	10.5	6	6	3.7	20.5	7	10.5	0.8	5.5	9	2.5	ch. 8	0.25	LM 30
RAL 24.06	RALR 24.06	24	6	8	11	M 8x1.25	14	7.7	7	5.6	27.5	11	14	1	6.5	14	4	ch. 13	0.5	LM 40
RAL 35.10	RALR 35.10	35	10	10	10	M10x1.25	20.65	10.5	14	7	43	15.9	20.5	1	13	18	5	ch. 17	0.75	LM 65
RAL 42.10	RALR 42.10	42	10	17	17	M12x1.25	24	12.5	12	9.5	49	19	23.5	1.5	11	25	6	ch. 19	0.75	LM 120

Type		Bearing rating (N)		Limit loads (N) ⁽⁵⁾	Torque wrench ⁽²⁾ settings (Nm)	Weight (g)
		Dynamic	Static			
		C _w ⁽³⁾	radial C _{or}	radial F _r		
RAL 17.06	RALR 17.06	1 500	840	470	1.8	20
RAL 24.06	RALR 24.06	4 200	2 300	1 500	8	40
RAL 35.10	RALR 35.10	7 900	5 100	3 800	20	130
RAL 42.10	RALR 42.10	12 100	7 100	3 200	24	185

1) Housing bore tolerance: H7

2) The torque wrench settings are given for non-lubricated threads; for lubricated threads, multiply figure by 0.8

3) C_w basic load for 100 km

4) The guide rollers are complete with self-locking washers and hexagonal nut for fitting

5) Dimension X is the max displacement from dimension m to ensure proper guide roller function and safety

Guide Wheels **GLA**

NEW Now available in stainless steel

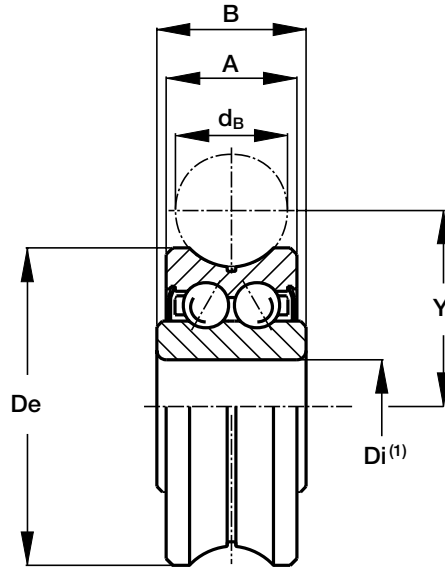

Type	Dimensions (mm)					
	De	dB	Di ⁽¹⁾	Y	A	B
GLA 17.06⁽⁴⁾	17	6	5	10.5	7	8
GLA 24.06⁽⁴⁾	24	6	8	14	11	11
GLA 35.10⁽⁴⁾	35	10	12	20.65	15.9	15.9
GLA 35.12	35	12	12	21.75	15.9	15.9
GLA 42.10	42	10	12	24	19	19
GLA 47.10	47	10	15	26.65	19	19

Type	Bearing rating (N)			Life coefficients				Weight (g)
	Dynamic C _w ⁽²⁾	Static		Pa/Pr ≤ 0.37		Pa/Pr > 0.37		
		radial C _{or}	axial C _{oa}	X	Y	X	Y	
GLA 17.06	1 500	840	350	1	1.37	0.5	2.73	10
GLA 24.06	4 200	2 300	1 000	1	1.37	0.5	2.73	20
GLA 35.10	7 900	5 100	1 500	1	1.67	0.5	3.03	80
GLA 35.12	7 800	5 000	1 400	1	2.47	0.5	3.83	80
GLA 42.10	12 000	7 100	2 100	1	1.17	0.5	2.53	100
GLA 47.10	15 400	9 200	3 300	1	0.97	0.5	2.33	170

1) Tolerance of Diameter Di: +0 / -0.008 mm

2) C_w basic load for 100 km

3) Pressure angle α for load calculation: 60°

4) Available in stainless steel (suffix NX) with RS seals type

5) Standard seals ZZ type

Carriage C3RCL, C3RAL, C3RYL

NEW Now available with stainless steel rollers

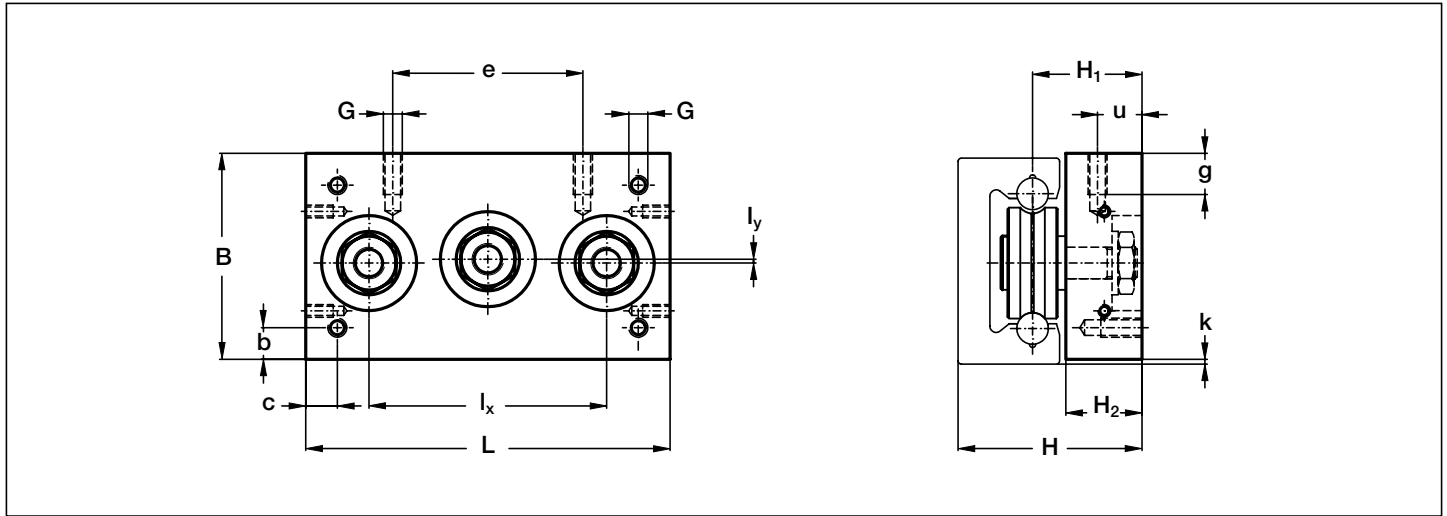

Type	Dimensions (mm)														Weight (kg)	Recommended pairings
	L	B	I _x	I _y	H	H ₁	H ₂	G	g	b	c	u	e	k		
C3RCL 17 06 065	65	32	40	0.5	27.5	17	11	M4	6	4	6	5.5	24	0.5	0.1	LM 30
C3RCL 24 06 085	85	42	58	1	35.7	21.7	14	M5	8	6	6	7	35	1	0.2	LM 40
C3RCL 35 10 115	115	65	75	1.2	58	34.5	24	M6	10	10	10	14	60	1.5	0.8	LM 65

Note: the carriages are preset for fitting RS track cleaners

1) Dimensions valid also for C3RAL and C3RYL
2) Available with stainless steel rollers (suffix NX)

Carriage C4RCL, C4RAL, C4RYL

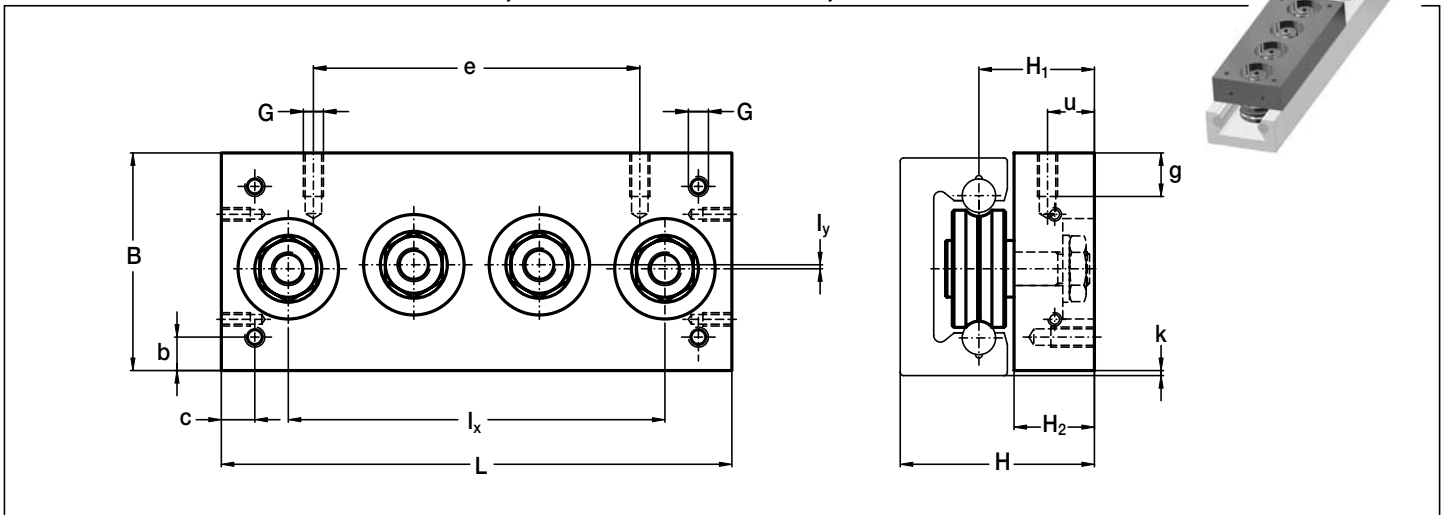
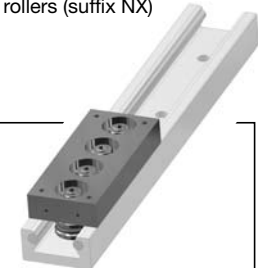

Type	Dimensions (mm)														Weight (kg)	Recommended pairings
	L	B	I _x	I _y	H	H ₁	H ₂	G	g	b	c	u	e	k		
C4RCL 17 06 085	85	32	60	0.5	27.5	17	11	M4	6	4	6	5.5	44	0.5	0.15	LM 30
C4RCL 24 06 114	114	42	87	1	35.7	21.7	14	M5	8	6	6	7	60	1	0.25	LM 40
C4RCL 35 10 152	152	65	112.5	1.2	58	34.5	24	M6	10	10	10	14	90	1.5	1	LM 65

1) Carriages are complete with guide rollers
2) Wipers RS available

3) Dimensions valid also for C4RAL and C4RYL
4) Available with stainless steel rollers (suffix NX)

Carriage **T4RCL, T4RCP, T4PFV** **T4RAL, T4RYL**

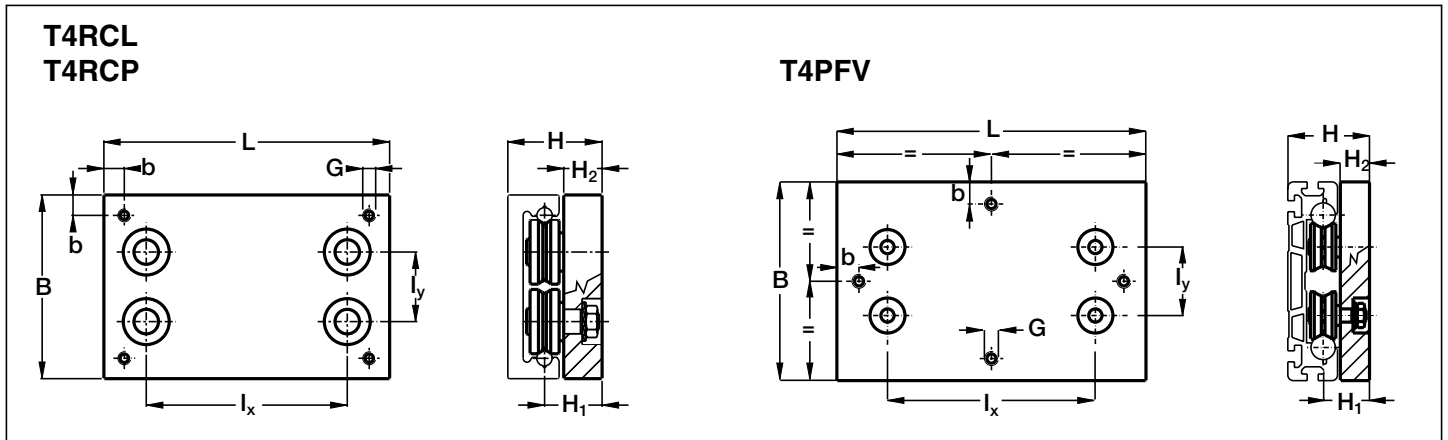

Type	Dimensions (mm)									Weight (kg)	Recommended pairing
	L	B	I _x	I _y	H	H ₁	H ₂	G	b		
T4RCL 35 10 150	150	120	99	50.7	58.5	34.5	24	M8	10	1.6	LM 120
T4RCL 35 10 220	220	120	169	50.7	58.5	34.5	24	M8	10	2.2	LM 120
T4RCP 42 10 150	150	120	99	44	65.5	41.5	29	M8	15	2	LM 120
T4RCP 42 10 220	220	120	169	44	65.5	41.5	29	M8	15	2.7	LM 120
T4PFV 43 22 180	180	180	127	62	74	42	28	M10	20	3.1	LM 180
T4PFV 43 22 280	280	180	227	62	74	42	28	M10	20	4.5	LM 180

Carriages are complete with guide rollers

1) Dimensions valid also for T4RAL and T4RYL

Wiper **RS**

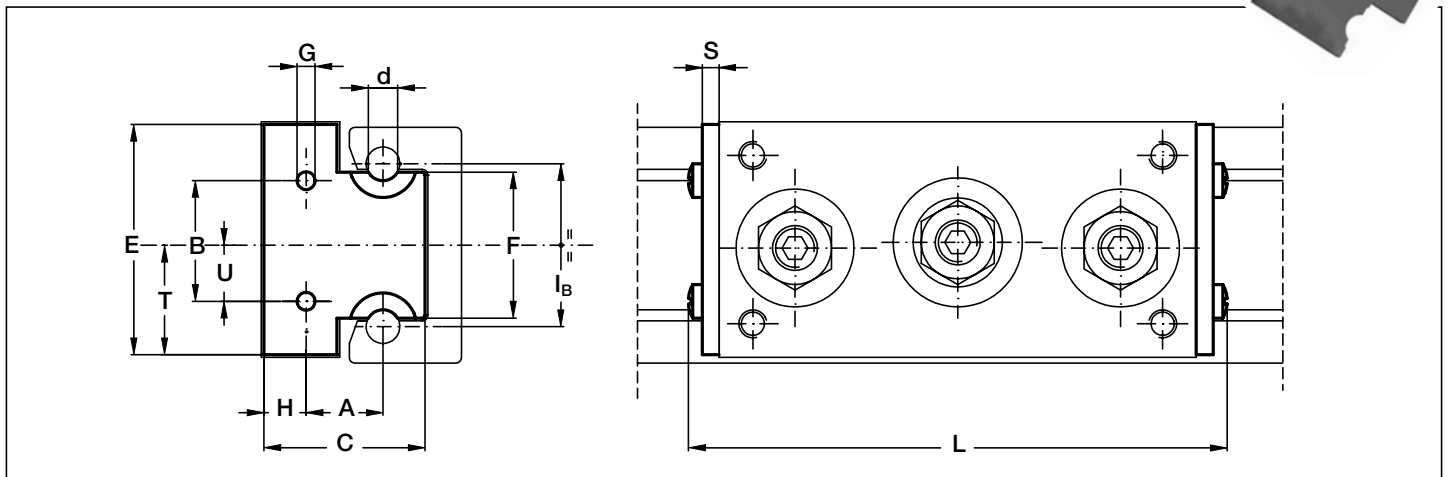

Type	Dimensions (mm)													Recommended pairing with guides	Recommended pairing with carriages	
	A	B	C	E	F	G	H	S	d	I _B	U	T	L _{C3 RCL}			L _{C4 RCL}
RS 030	9.5	16	22	30	18.5	2.8	7	3	6	21.5	8	15	76	96	LM 30	C3RCL 17 06 065
RS 040 CD/CS*	13.7	21.5	28.7	41	26	3.4	7.5	3	6	29	10	19.5	96	125	LM 40	C3RCL 24 06 085
RS 065 CD/CS*	20.5	30	47	65	38.5	4.5	14	5	10	42.5	15	31	132	169	LM 65	C3RCL 35 10 115

* Code CD indicates the right hand track cleaner, code CS indicates the left hand track cleaner.

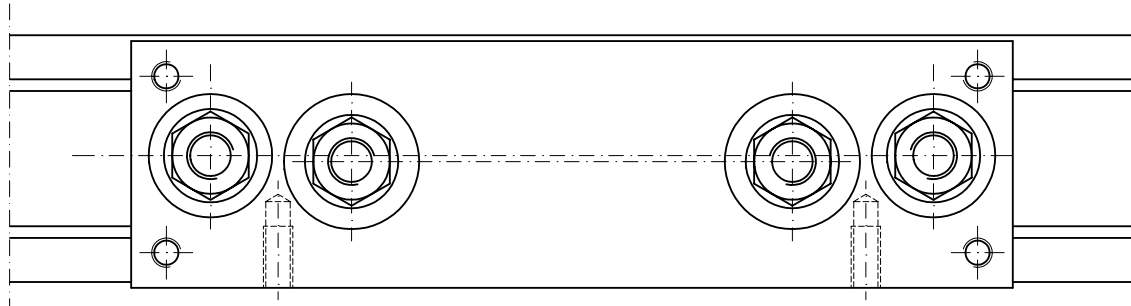

• Example of special design carriage

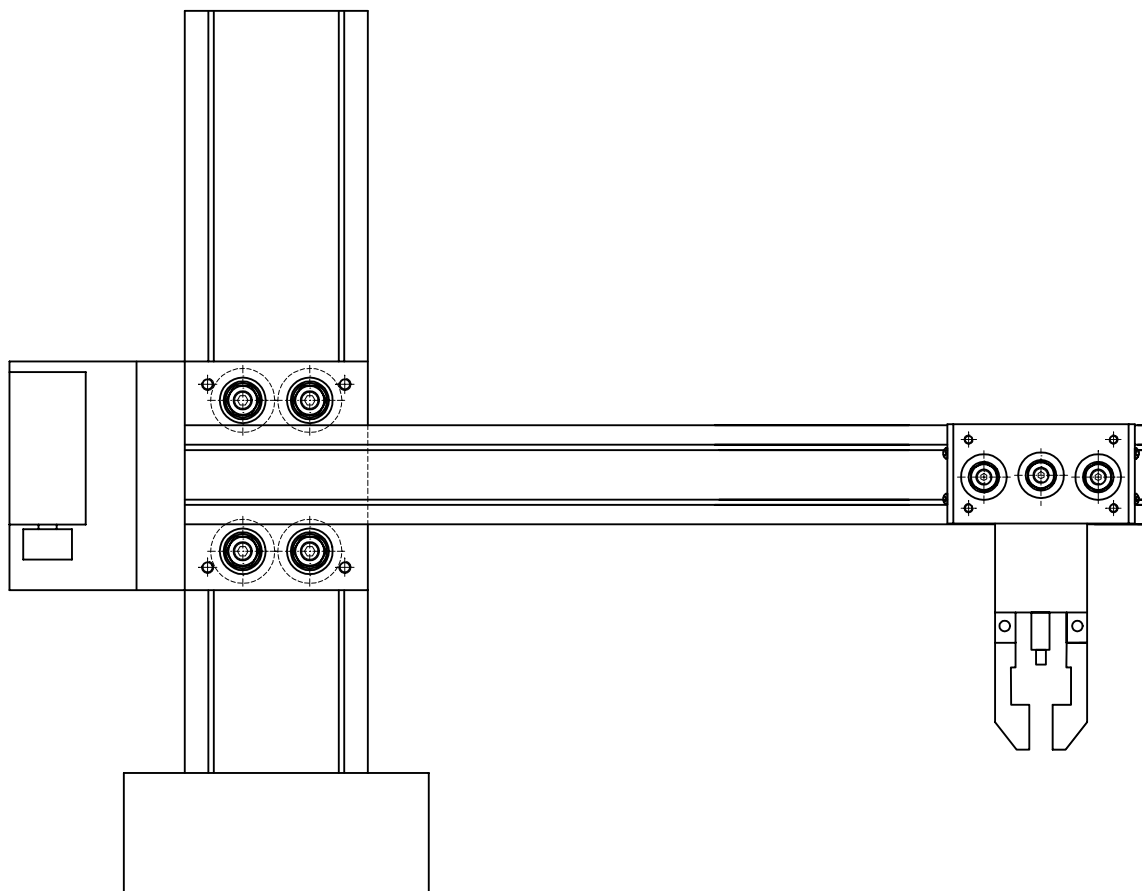

• Joystick for handling test samples



Notes

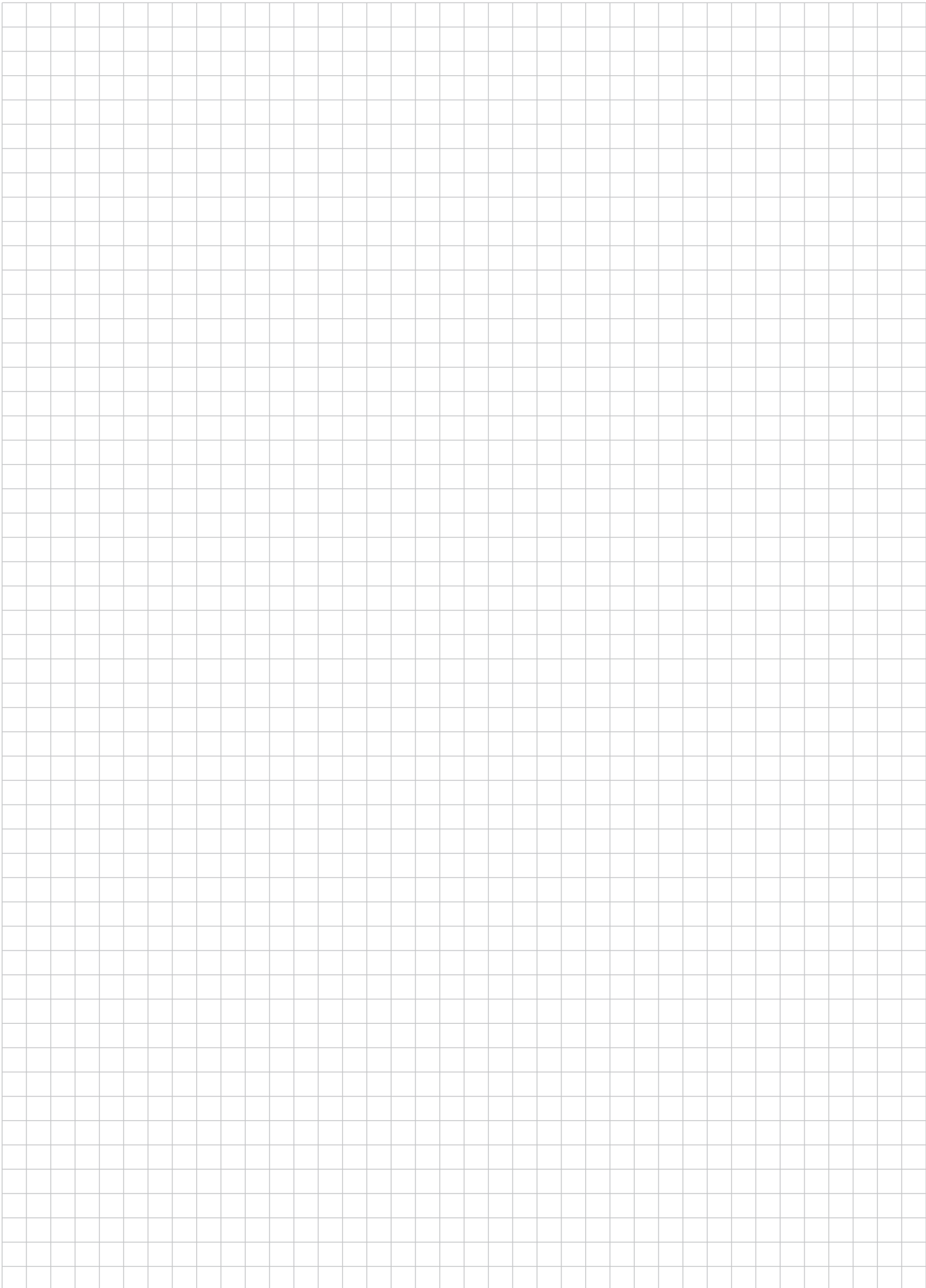

3D CAD DRAWINGS

***web2* CAD**

*Our 2D and 3D drawings can be
down loaded from our web site:*

www.nadella.it

