

# TORQUE LIMITERS - CLUTCHES

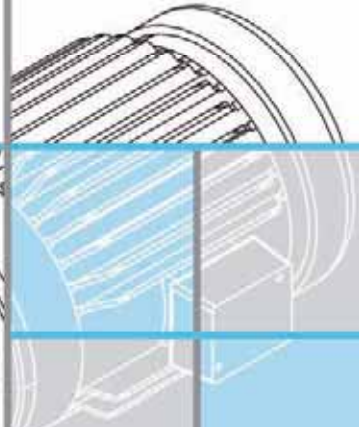
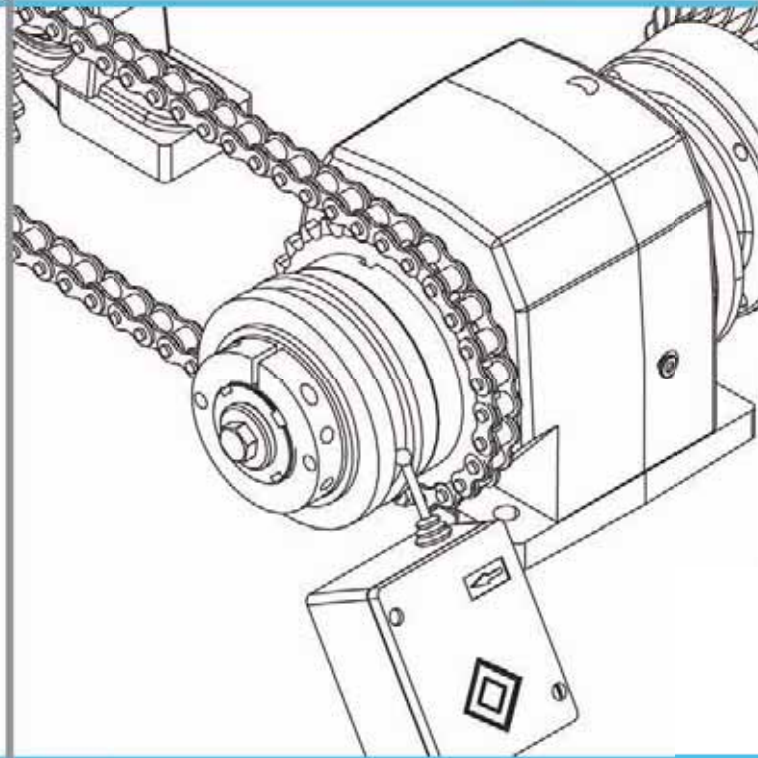

# TORQUE LIMITERS - CLUTCHES: introduction

ComInTec torque limiters are mechanical components necessary to fit along the kinematic chain and are preferred to electronic safety devices because of a better response time, improved reliability, excellent configuration flexibility, easy fitting and adjustment, use at high speeds in hard environments in the presence of inertias and important masses. In fact the electronic systems, which normally act up to the transmission, present: delayed reaction time, many factors as a source of error, configuration and management complexity. The fitting of the mechanical torque limiters along the kinematic chain is therefore necessary for a reliable and complete protection, in order to improve the level of safety and the machine, according to the new EN ISO 13489-1 standards, reducing the average possible broken-down and unproductive downtime.

### Benefits of our models ...

- Long product life with continuous reliability.
- Optimum protection against environmental conditions.
- Simple mounting for in-line and parallel transmission.
- Easy setting and adjustment.
- Highly accurate and fast machine protection.
- Special designs to suit specific applications possible.
- Competitive pricing without sacrificing quality.
- "Made in Italy" with certified quality.

### Our product range ...

- "DF": Simple, economical and suitable for dry and dusty conditions.
- "EDF/F": Compact and low cost ball version available with sprocket or flange.
- "DSS or DSR": Offering high stability during operation. Re-synchronising in various positions possible. A full range of mounting options are possible.
- "DSS/SG": Allows immediate disconnection without any residual torque remaining.
- "DSA": Suitable for limiting compression and tension forces on crank mechanisms.
- "AP": Possibility of varying the transmission torque during operation and allowing for full disengagement with free rotation if required.

FRICITION TORQUE LIMITER "DF"



Overload protection device with a sprocket mounted between two friction discs that slide without disengaging when it reaches the pre-set peak torque. The torque is adjustable by altering the spring pressure.

14

ECONOMY BALL TORQUE LIMITER "EDF/F"



Economical overload protection device with ball transmission via a customized sprocket that disengages fully when it reaches the pre-set peak torque. The torque is steplessly adjustable by altering the spring pressure.

16

BALL OR ROLLER TORQUE LIMITER "DSS or DSR"



Overload protection device with Ball or Roller transmission, which disengages fully at the pre-set peak torque. The torque is steplessly adjustable by altering the spring pressure.

25

BACKLASH FREE TORQUE LIMITER "DSS/SG"



A backlash free overload protection device with ball transmission, that disengages fully at the pre-set peak torque. Very high sensitivity possible with negative spring version.

32

AXIAL FORCE LIMITER "DSA"



Device that disengages in the axial direction (in compression and tension) at the pre-set force by altering the spring pressure.

33

PNEUMATIC CLUTCHES "AP"



Friction or roller clutches with adjustment of the peak torque possible remotely by altering the pneumatic pressure.

33

## HOW TO SELECT

Model	Function	Torque [Nm]	Max bore [mm]	Speed [Rpm]	Main characteristics	Sensitivity
DF	friction	1 ÷ 23000	140	medium - low	available with platewheel	medium-low
EDF/F	mechanical	7,5 ÷ 1450	55	medium - low	with balls in phase	medium-high
DSS	mechanical	2,5 ÷ 2050	68	medium - high	with equidistant balls	high
DSR	mechanical	10 ÷ 12000	120	medium - low	with rollers in phase or equidistant	medium-high
DSR/F/RF	mechanical	25 ÷ 1460	68	medium - low	free rotation with roller in phase	medium-high
DSS/SG	mechanical	5 ÷ 750	50	medium - high	backlash free with balls in phase or equidistant	high
DSA	mechanical	Force 30 ÷ 7000 N	-	medium	axial coupling	medium-high
DSR/F/AP	pneumatic	7 ÷ 30000	120	high	coupling with rollers in phase	high
DSF/TF/AP	pneumatic	3 ÷ 875	65	medium - high	slipping function	medium

### FRICITION TORQUE LIMITERS



Transmission with parallel shafts



Transmission with in-line shafts

### BALLS OR ROLLERS TORQUE LIMITERS



Transmission with parallel shafts



Transmission with in-line shafts

# "DF" FRICTION TORQUE LIMITER: introduction



- Simple and economic friction torque limiter.
- Suitable for dusty conditions without need of timing between gearbox and output.
- Silent overload without vibration.
- Protection in both rotation directions.      ○ Asbestos-free friction discs.
- Simple and precise torque setting by adjusting the locking ring.
- The innovative setting of the nominal torque by measuring the "H" dimension allows for immediate coupling calibration.

### ON REQUEST

- Complete with transmission gear, fully turned and mounted (plate wheel, pulley, gear pair)
- Different types of friction discs for specific applications.
- Possibility of connections with bore and keyway, locking assembly or other locking systems.
- Anti-corrosive surface treatments for special requirements.

	DF: Basic model for parallel shaft transmission, with plate wheels, gear pairs or pulleys.	from 1 to 23000 Nm max. bore $\varnothing$ 140 mm	Page 5
	DF/SI: signaling on overload and automatic re-engaging possible.	from 3 to 23000 Nm max. bore $\varnothing$ 140 mm	Page 6
	DF/PR: designed for the application on the slow speed shaft of a worm-gearbox.	from 1 to 2600 Nm max. bore $\varnothing$ 55 mm	Page 7
	DF/TAC/PR-V: designed for application on the high speed shaft of a worm-gearbox.	from 1 to 1200 Nm max. shaft - bore $\varnothing$ 55 mm	Page 7
	DF/TAC: in-line shaft connection, simple and economic.	from 1 to 23000 Nm max. bore $\varnothing$ 140 mm	Page 8
	... + GAS: in-line shaft connection with elastic coupling with high misalignments.	from 1 to 7200 Nm max bore $\varnothing$ 110 mm	Page 9
	... + GEC: in-line shaft connection with compact elastic coupling.	from 1 to 800 Nm max bore $\varnothing$ 160 mm	Page 9

## MAIN APPLICATIONS

- Forming machines.
- Conveyors.
- Automotive.
- Agricultural machines, woodworking machines.

## ADVANTAGES AND BENEFITS

- Protects the motor-gearbox in case of accidental collision.
- Protects the film of wrapping machines in case of higher tension.
- Absorbs static torques without disengaging.
- Protects the gear in case of short product jam.

## APPLICATION EXAMPLES

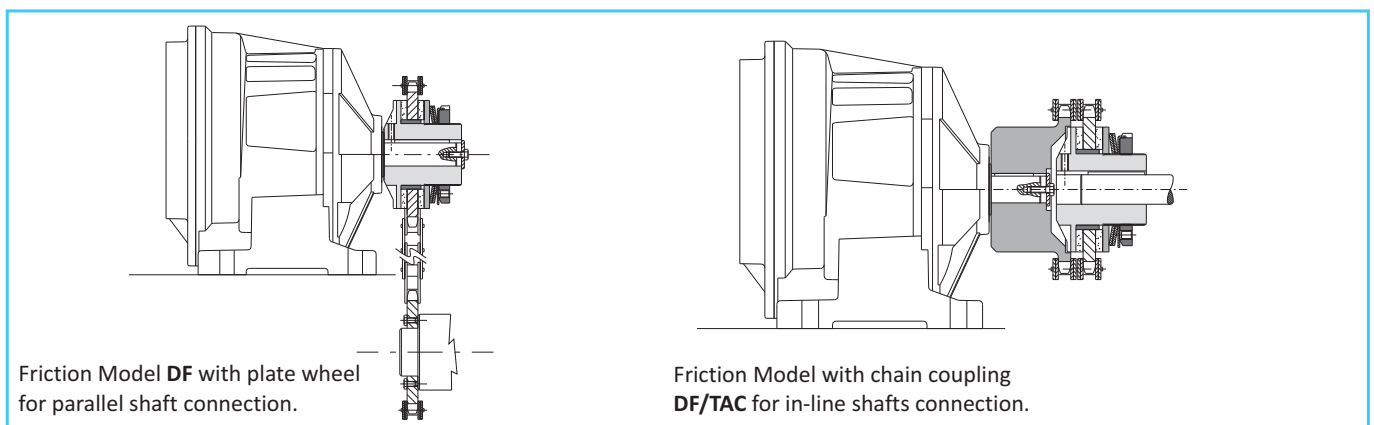

# DF (friction torque limiter): technical data

- Compact solution.
- Assembly with helical springs possible: .../CM.
- Available with anti-corrosive surface treatments: DF/EA.
- Torque range: 2-23000 Nm; max. bore:  $\varnothing 140$  mm.
- Available with customized alignments ("L" quote) interchangeable with other models present on the market.
- Available with radial nut (.../GR) statically balanced.

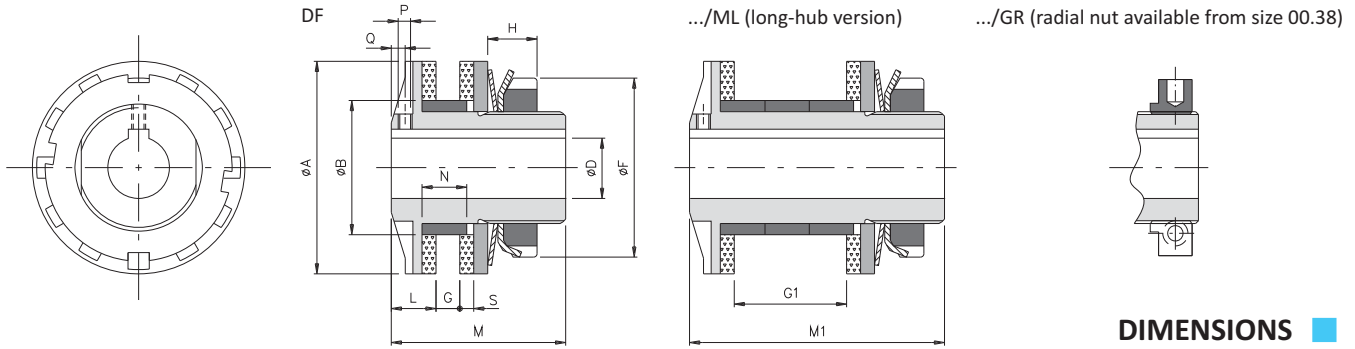

## DIMENSIONS

Size	Torque [Nm]	A	B h7	D H7		F	G		G1	L	M	M1	N	P	Q	S	Max. speed [Rpm]	Weight [Kg]
				pilot bore	max.		min.	max.										
00.25	1 - 20	25	14	-	8	22	1	3	-	5	26	-	5,5	M3*	3*	2	10000	0,1
00.38	1 - 34	38	24	-	12	32	1	5	21	8	33	46	8	M3	2	2,5	10000	0,2
0.50	2 - 100	50	36	-	20	44	1	6	26	10	35	57,5	10	M4	3	3	7600	0,4
1.70	6 - 210	70	45	-	25	63	1	10	40	15	55	85	15	M6	4,5	4	5450	1,1
2.90	10 - 450	90	60	-	38	82	3	12	46	16	60	95	17	M6	5,5	4	4250	2,2
3.115	26 - 950	115	72	18	45	105	5	16	58	18	70	113	21	M6	5,5	4	3350	3,7
4.140	80 - 1200	140	85	24	55	130	8	19	69	20	80	136	25	M8	6,5	5	2750	6,6
5.170	150 - 2600	170	98	28	65	158	10	22	78	22,5	95	153,5	28	M8	6,5	5	2250	10,9

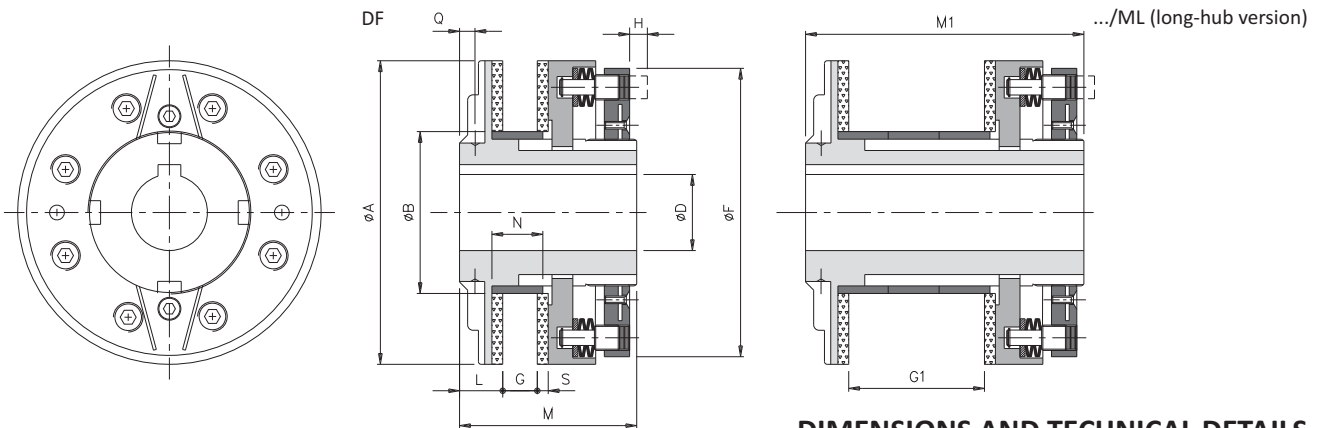

## DIMENSIONS AND TECHNICAL DETAILS

Size	Torque [Nm]	A	B h7	D H7		F	G		G1	L	M	M1	N	S	On request Q	Max. speed [Rpm]	Weight [Kg]
				pilot bore	max.		min.	max.									
6.205	300 - 4800	205	120	38	80	193	18	26	90	27	110	174	32	5	8,5 - M8	1900	20,1
7.240	500 - 8000	240	145	50	100	230	21	29	99	27	116	186	35	5	8,5 - M10	1600	30,9
8.300	800 - 14000	300	175	60	120	287	21	33	113	29	123	203	40	6	8,5 - M10	1300	49,1
9.340	1000 - 18000	340	205	60	130	325	23	33	113	41	158	238	40	6	12 - M12	1200	85,5
10.400	1500 - 23000	400	230	60	140	388	23	35	119	46	167	251	42	6	13 - M12	1000	124,5

## NOTES

- ⊗ P-Q\*: On the size 00.25 the grub screw is located on the nut side, not on the flange side.
- ⊗ Technical details: Weights are relevant to the torque limiter with pilot bore (DF).

## .../SI (intervention signaling version): technical data



- Electromechanical overload signaling.
- Automatic re-engaging after transmission reset.
- Assembly with helical springs possible: .../SI/CM.
- Available with a longer shaft for assembly with transmission elements of large size: .../SI/ML.
- Available with friction rings at different performances for specific needs.
- Torque range: 3 – 23000 Nm; max. bore:  $\varnothing 140$  mm.

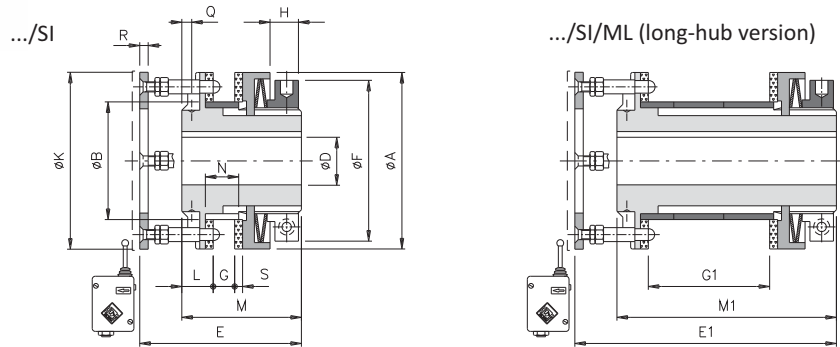

### DIMENSIONS AND TECHNICAL DETAILS

Size	Torque [Nm]	A	B h7	D H7		E	E1	F	G		G1	K	L	M	M1	N	R	S	On request Q	Max speed [Rpm]	Weight [Kg]
				pilot bore	max.				min.	max.											
1.70	6 - 210	70	45	-	25	75	105	63	5	10	40	70	15	55	85	15	3	4	4,5 - M4	5450	1,4
2.90	10 - 450	90	60	-	38	80	114	82	7	12	46	90	16	61	95	17	3	4	5 - M6	4250	2,7
3.115	26 - 950	115	72	18	45	89	131	104	9	16	58	115	18	71	113	21	4	4	5 - M6	3350	4,9
4.140	80 - 1200	140	85	24	55	103	152	128	13	19	69	140	20	86	136	25	4	5	6 - M6	2750	7,8
5.170	150 - 2600	170	98	28	65	116	172	157	15	22	78	170	22,5	97,5	153,5	28	4	5	6,5 - M8	2250	12,9

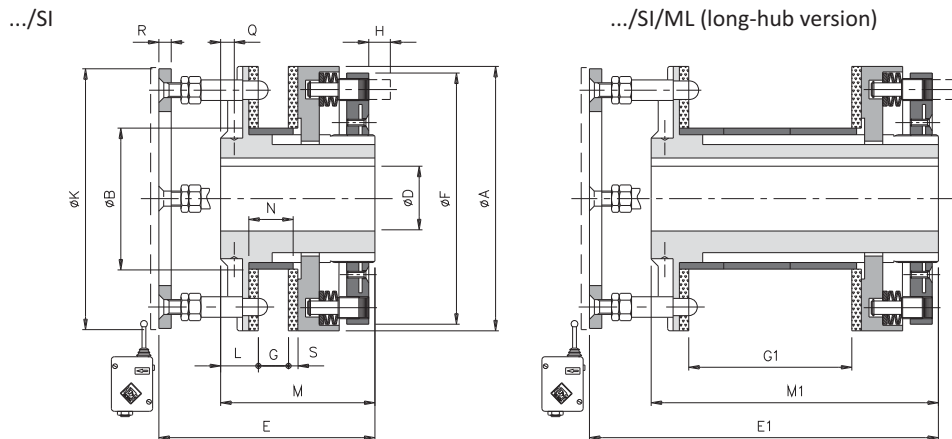

### DIMENSIONS AND TECHNICAL DETAILS

Size	Torque [Nm]	A	B h7	D H7		E	E1	F	G		G1	K	L	M	M1	N	R	S	On request Q	Max. speed [Rpm]	Weight [Kg]
				pilot bore	max.				min.	max.											
6.205	300 - 4800	205	120	38	80	124	188	193	18	26	90	205	27	110	174	32	4	5	8,5 - M8	1900	20,9
7.240	500 - 8000	240	145	50	100	131	201	230	21	29	99	240	27	116	186	35	6	5	8,5 - M10	1600	32,2
8.300	800 - 14000	300	175	60	120	136	216	287	21	33	113	300	29	123	203	40	6	6	8,5 - M10	1300	50,6
9.340	1000 - 18000	340	205	60	130	170	250	325	23	33	113	340	41	158	238	40	6	6	12 - M12	1200	88
10.400	1500 - 23000	400	230	60	140	175	260	388	23	35	119	400	46	167	251	42	6	6	13 - M12	1000	128,8

### NOTE

- Technical details: weights are relevant to the torque limiter with pilot bore (DF/SI).

## .../PR - .../TAC/PR-V (versions for gearboxes): technical data

- Friction rings available in various materials and performance to suit specific needs.
- More simple and higher sensitivity than in gearbox integrated solutions.
- Specifically for assembly with hollow shafts with model (.../PR).
- Specifically for assembly between motor and gearbox complete with aluminium spacer (.../TAC/PR-V).
- ABS** Certification for application in the Naval sector (.../TAC/PR-V).
- Torque range: 1 – 2600 Nm (.../PR), 1 – 1200 Nm (.../TAC/PR-V); maximum shaft:  $\varnothing$  55 mm.

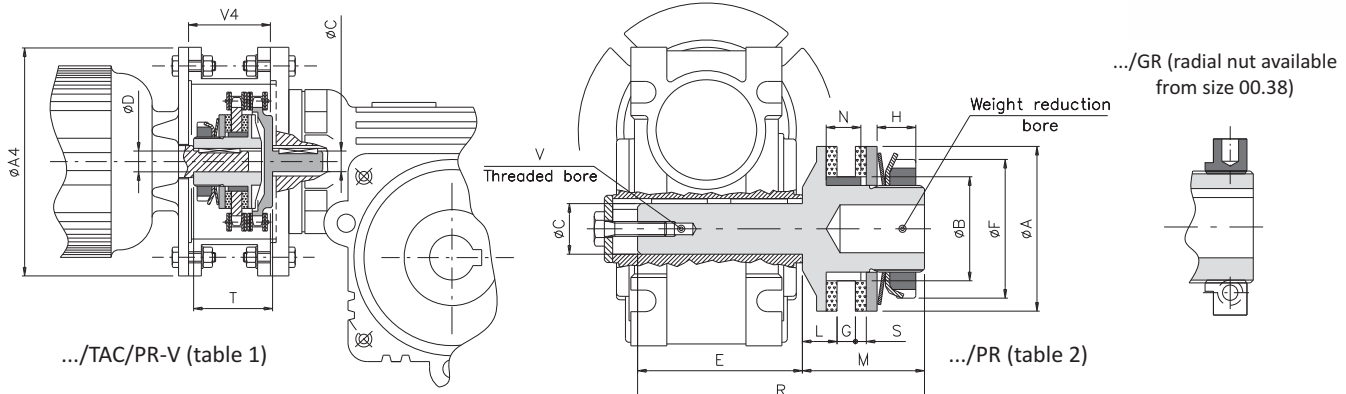

table 1

### DIMENSIONS AND TECHNICAL DETAILS

Size	Torque [Nm]	Engine type	DF/TAC/PR-V		Spacer on request for flange B5		Max speed [Rpm]	Weight [Kg]
			D H7 - C h7	T	A4	V4		
00.38	1 - 34	63a	11	43	140	43	5000	0,6
		71a	14 *		160	43		0,6
0.50	2 - 100	80a	19	45	200	45,5	3800	1
		90S	24 *			55,5		0,9
1.70	6 - 210	100La - 112M	28	64	250	66	2800	2,6
2.90	10 - 450	132M	38	72	300	83,5	2200	5,4
3.115	26 - 950	160L	42	104	350	120	1800	10,2
		180L	48					10,4
4.140	80 - 1200	200L	55	104	400	122	1500	18

table 2

Size	Torque [Nm]	A	B h7	C h7	E	F	G		L	M	N	R	S	V	Max speed [Rpm]	Weight [Kg]
							min.	max.								
00.38	1 - 34	38	24	11	48	32	2,5	5	8	33	8	81	2,5	M4x10	10000	0,2
0.50	2 - 100	50	36	14	53	44	3,5	6	10	35	10	88	3	M5x13	7600	0,4
1.70	6 - 210	70	45	18	62	63	5	10	15	55	15	117	4	M6x16	5450	1,1
				19	78							133				1,1
				24	90							145				1,3
				25	80							135				1,2
2.90	10 - 450	90	60	25	90	82	7	12	16	60	17	150	4	M8x20	4250	2,1
				28	110							170				2,3
3.115	26 - 950	115	72	32	120	105	9	16	18	70	21	190	4	M10x25	3350	3,7
				35	118							188				3,9
				38	138							208				4,2
4.140	80 - 1200	140	85	42	152	130	13	19	20	80	25	232	5	M12x32	2750	6,9
				45	163							243				7,2
				48	178							258				7,7
5.170	150 - 2600	170	98	50	167	158	15	22	22,5	95	28	262	5	M16x40	2250	11,5
				55	208							303				12,7

### NOTES

- ⊗ DH7\*: reduced keyway on the torque limiter.
- ⊗ Technical details: weights are relevant to the torque limiter with pilot bore (DF/PR – DF/TAC/PR-V).

## .../TAC (version with chain coupling): technical data

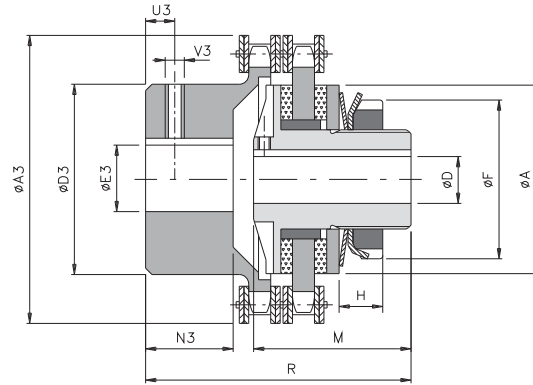

.../GR (radial nut available from size 00.38)

### DIMENSIONS AND TECHNICAL DETAILS

Size	Torque [Nm]	A	D H7		M	P	Q	R	A3	D3	E3 H7		N3	U3	V3	Max speed [Rpm]	Weight [Kg]
			pilot bore	max.							pilot bore	max.					
00.25	1 - 20	25	-	8	26	M3	3	39	45	23	8	12	9	4	M3	5000	0,2
00.38	1 - 34	38	-	12	33	M3	3	58	58	37	10	20	20	5	M3	5000	0,6
0.50	2 - 100	50	-	20	35	M4	4	58	75	50	12	28	19	8	M4	3800	1,1
1.70	6 - 210	70	-	25	55	M6	6	87	101	70	16	38	29	8	M4	2800	2,8
2.90	10 - 450	90	-	38	60	M6	6	102	126	89	20	55	38	12	M6	2200	5,9
3.115	26 - 950	115	18	45	70	M6	6	131	159	112	20	70	56,5	12	M6	1800	11,1
4.140	80 - 1200	140	24	55	80	M8	8	146	184	130	28	80	59,5	15	M8	1500	20,3
5.170	150 - 2600	170	28	65	95	M8	8	189	216	130	30	80	88	15	M8	1300	31,0

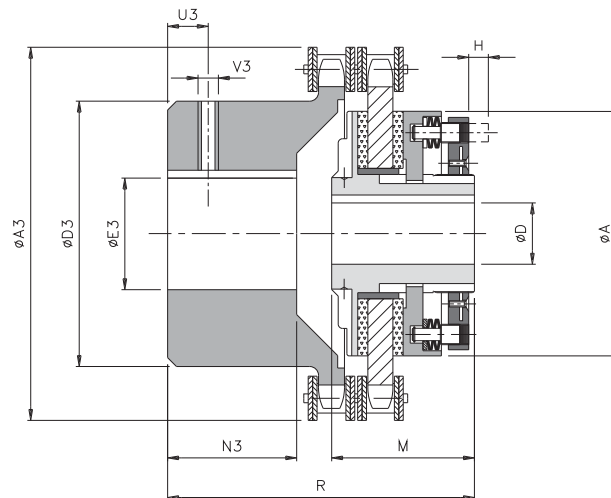

### DIMENSIONS AND TECHNICAL DETAILS

Size	Torque [Nm]	A	D H7		M	R	A3	D3	E3 H7		N3	U3	V3	Max speed [Rpm]	Weight [Kg]
			pilot bore	max.					pilot bore	max.					
6.205	300 - 4800	205	40	80	110	218	291	150	38	90	103	25	M10	1000	54,6
7.240	500 - 8000	240	50	100	116	245	312	170	50	110	124	25	M10	900	76,7
8.300	800 - 14000	300	60	120	123	284	374	200	50	140	147	30	M12	750	125,5
9.340	1000 - 18000	340	60	130	158	329	423	210	60	150	165	30	M12		
10.400	1500 - 23000	400	60	140	167	364	471	240	60	160	191	30	M16		

### NOTES

- ⊗ **Technical details:** data is relevant to the whole group (DF/TAC).
- ⊗ **Technical details:** weights are relevant to the whole group with pilot bore (DF/TAC).



## ... + GAS (jaw coupling model): technical data

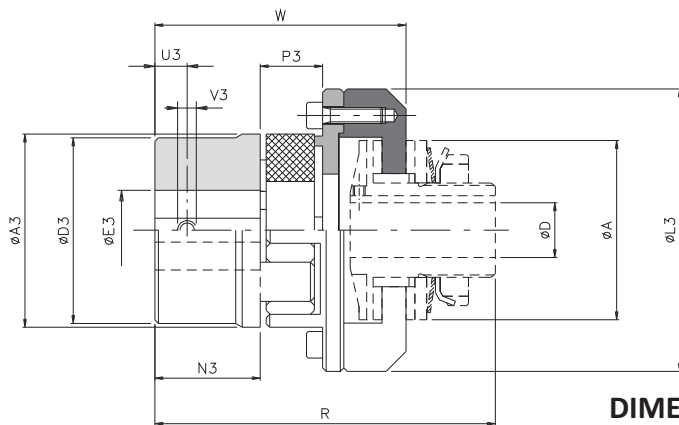

**DIMENSIONS AND TECHNICAL DETAILS**

Size		Torque [Nm]		A3	D3	E3 H7 max.	L3	N3	P3	U3	V3	D H7		R	W	Misalignments*			Max speed [Rpm]	Weight [Kg]
DF	GAS	Nom.	Max.									pilot bore	max.			Angular $\alpha$ [°]	Axial X [mm]	Radial K [mm]		
00.25	01 (14)	12,5	25	30	30	16	43	11	12	5	M4	-	8	56	37,5	0°54'	1	0,09	10000	0,2
00.38	00 (19)	17	34	40	40	25	58	25	16	10	M5	-	12	84,5	64	1° 18'	1	0,4	10000	0,4
0.50	0 (24)	60	120	55	53	35	74	30	18	10	M5	-	20	94	74,5	1° 18'	1	0,8	7600	0,8
1.70	2 (38)	325	650	80	78	48	107	45	24	15	M8	-	25	135	104	1° 18'	1,4	1	5450	3,3
2.90	3 (42)	450	900	95	93	55	132	50	26	20	M8	-	38	148,5	115,5	1° 18'	1,6	1	4250	5,4
3.115	5 (55)	685	1370	120	118	74	164	65	30	20	M10	18	45	181,5	143,5	1° 18'	1,8	1,4	3350	10,3
4.140	7 (75)	1465	2930	160	158	95	208	85	40	25	M10	24	55	224	181	1° 18'	2,5	1,8	2750	21,1
5.170	8 (90)	3600	7200	200	180	110	248	100	45	30	M12	28	65	260	207,5	1° 18'	2,8	1,8	2250	36,3

## ... + GEC (compact elastic coupling model): technical data

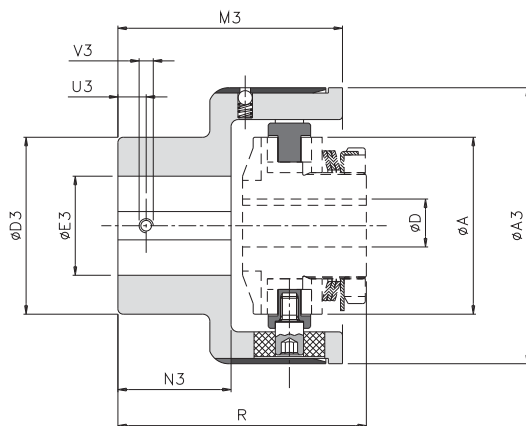

**DIMENSIONS AND TECHNICAL DETAILS**

Size		Torque [Nm]		A3	D3	E3 H7		M3	N3	U3	V3	A	D H7		R	Misalignments			Max. speed [Rpm]	Weight [Kg]
DF	GEC	Nom	Max			pilot bore	max.						pilot bore	max.		Angular $\alpha$ [°]	Axial X [mm]	Radial K [mm]		
00.38	00	35	50	63	42	5	20	60,5	29	8	M4	25	-	12	68	1°	±0,7	0,5	6000	0,8
0.50	0	70	110	78	50	10	28	63,5	32	10	M5	50	-	20	71,5	1°	±0,7	0,5	5500	1,41
1.70	1	280	420	108	70	12	38	89	49	12	M6	70	-	25	106	0° 48'	±0,7	0,5	5000	4,18
2.90	2	570	860	130	80	15	45	111	65	15	M8	90	-	38	129	0° 36'	±0,7	0,6	4250	7,45
3.115	3	980	1500	161	100	15	60	140	85	15	M8	115	18	45	159	0° 30'	±0,8	0,6	3350	13,4
4.140	4	2340	3600	206	120	20	70	168	105	20	M10	140	24	55	195	0° 24'	±0,8	0,6	2750	24,1
5.170	5	3880	5800	239	135	30	80	201	130	20	M10	170	28	65	232	0° 24'	±0,8	0,6	2250	37,9
6.205	6	15000	20000	312	215	40	150	260	165	25	M12	205	38	80	291	0° 24'	±0,8	0,6	1900	86,8
7.240	7	30000	35000	360	240	40	160	310	205	25	M12	240	50	100	342	0° 24'	±0,8	0,6	1500	160,5

### NOTES

- ⊗ ... + GAS (misalignments)\*: data relates to red elastomeric element 98Sh-A.
- ⊗ Technical details: data is relevant only to application (.../GAS-.../GEC), for torque limiter data see on page 5.
- ⊗ Technical details: weights are relevant only to the coupling application with pilot bore version (.../GAS-.../GEC).

## FRICITION TORQUE LIMITER “DF”: additional information

### VERSIONS ON REQUEST

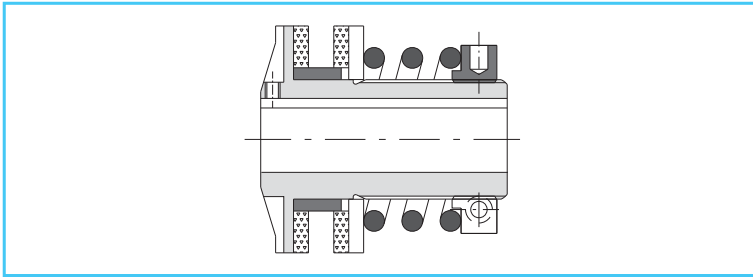

#### **.../CM: minimum torque version**

Helical springs execution, for a higher torque range and consequently, a finer adjustment on calibration is possible

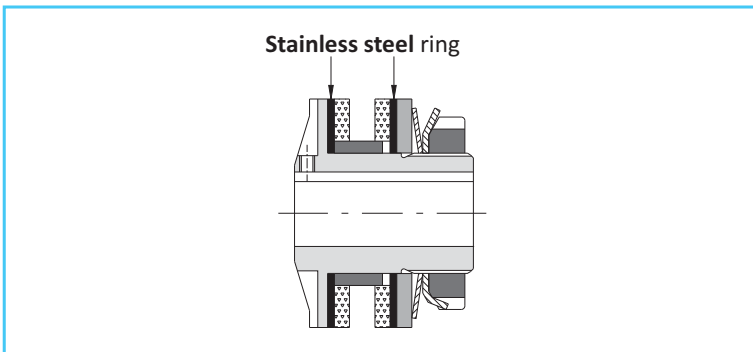

#### **.../EA: rust resistant**

Rust resistant execution, with stainless steel rings, galvanized for application in wet environments.

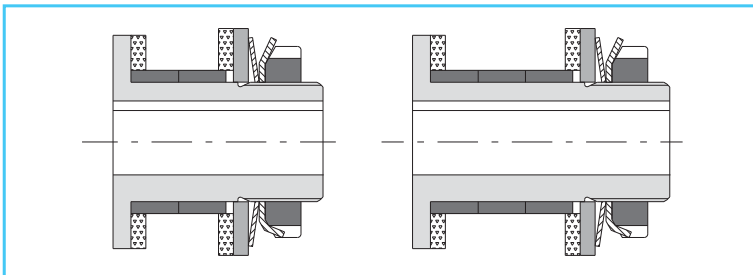

#### **.../MFR: reduced flange hub version**

Reduced flange hub execution, to assemble elements with reduced diameters. Available with two or three bushes version.

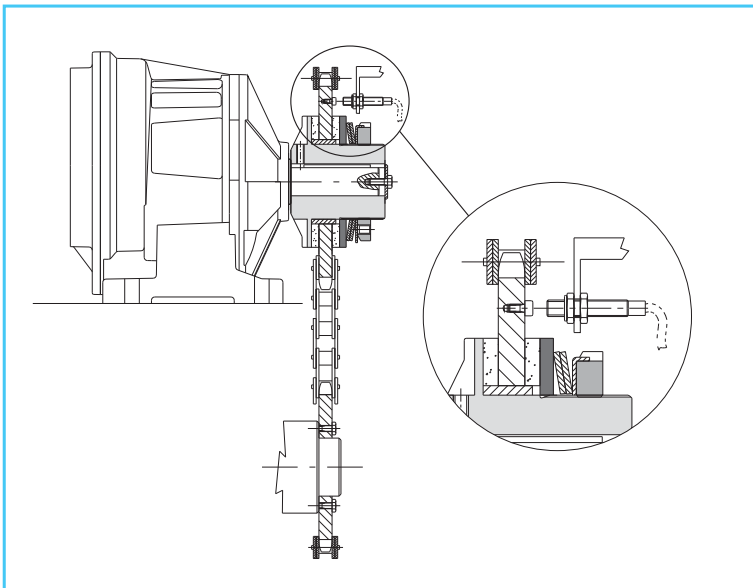

#### **.../MS: overload detection version**

Our suggestion to increase the life of the friction rings and to maintain the torque limiter efficiency is (it is possible and advised) to stop the machine immediately, on the first slip caused by an overload. This is possible by using one proximity inductive sensor, which registers any speed anomaly, as indicated in the picture.

VERSIONS ON REQUEST

**.../TAC/PR: version suitable for gearboxes and in-line shafts**

Model for gearboxes with chain coupling, suitable for an in-line shafts connection out of the gearbox.

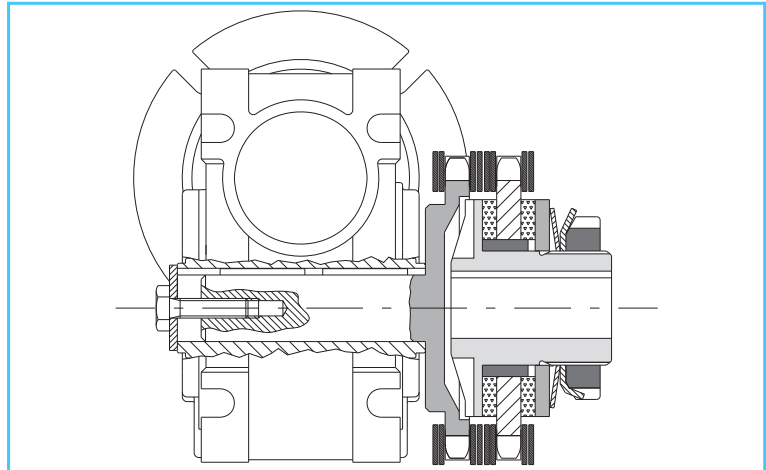

**DF + GF: with flexible coupling  
DF + GGF: with highly flexible coupling**

Models suitable for an in-line shafts connection and also able to accommodate high misalignments.

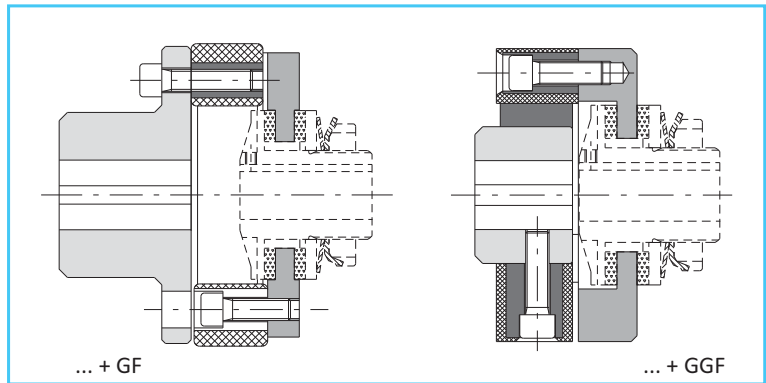

**VERSION WITH LOCKING ASSEMBLY**

Shaft connections possible with internal and external locking assemblies, eliminating backlash present in the keyway.

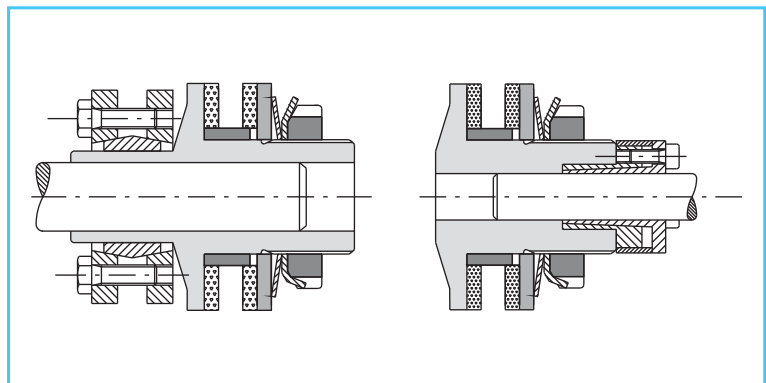

**GT/DR KIT: kit for double registration matching to the nut with notches GT**

Torque adjustment system by double registration (GT nut plus hexagonal head-screws) for high sensitivity and precision on calibration, also with belleville washers.

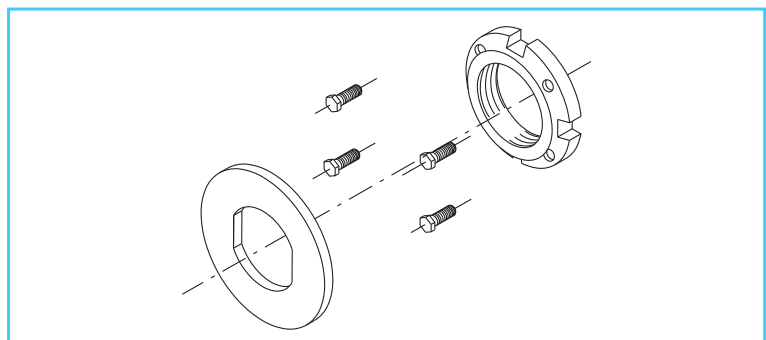

# FRICION TORQUE LIMITER "DF": additional information

## PLATE WHEELS

The driving part selected (plate wheels, pulleys, gears, and so on) to be incorporated into the friction torque limiter, must adhere to predetermined characteristics (ex. the surface in contact to the friction rings with roughness  $Ra=0,8 : 1,6$ ) to ensure good performance. In the table below, there are standard plate wheels in ComInTec's production (supplied already grounded) which can be assembled on the torque limiter; and the minimum chain passage "V" (see picture 3), necessary for the correct sizing of the plate wheel to avoid contact between the chain and outside diameter of the limiter. It is possible to assemble various types of plate wheels, but the surfaces must be machined, and the chain passage cannot be smaller than this value. Another aspect to take into consideration to ensure the dimension of the assembly is correct, is the element thickness and its relevant bush "N" (see picture 1). We suggest to obtain a quote "N" equal to  $[S + G + 1]$ . Comparing "N" value obtained, to the  $N_{std}$  indicated on the table, which corresponds to the standard length of the bushes, you can have: "N" < " $N_{std}$ " (picture 1 - ex.A) → reduce the bush width to quote "N".

"N" > " $N_{std}$ " (picture 2 - exB) → machine the driving part at a diameter of "A+1" and a depth equal to "x" ( $N - N_{std}$ ).

Example "A" (see picture 1)  
 1.70 with plate wheel #7  
 $G = 7 \text{ mm}$   
 $S = 4 \text{ mm}$   
 $N = S + G + 1 = 4 + 7 + 1 = 12$   
 $N_{std} = 15$   
 Reduce the bush width to 12 mm.

Example "B" (see picture 2)  
 1.70 with plate wheel #13  
 $G = 13 \text{ mm}$   
 $S = 4 \text{ mm}$   
 $N = S + G + 1 = 4 + 13 + 1 = 18$   
 $N_{std} = 15$   
 Machine  $\varnothing 71$  with depth (value "x"= $18-15=3$ )

where:  
 $p$  = pitch [in]  
 $G$  = thickness of the ground element  
 $Z$  = teeth number  
 $dp$  = pitch diameter  
 $S$  = thickness of the friction ring  
 $N_{std}$  = thickness of the standard bush  
 $N$  = thickness of the calculated bush ( $S+G+1$ )  
 $A$  = outside diameter of the torque limiter  
 $V$  = inside diameter of the chain  
 $x$  = depth of the machining ( $N - N_{std}$ )

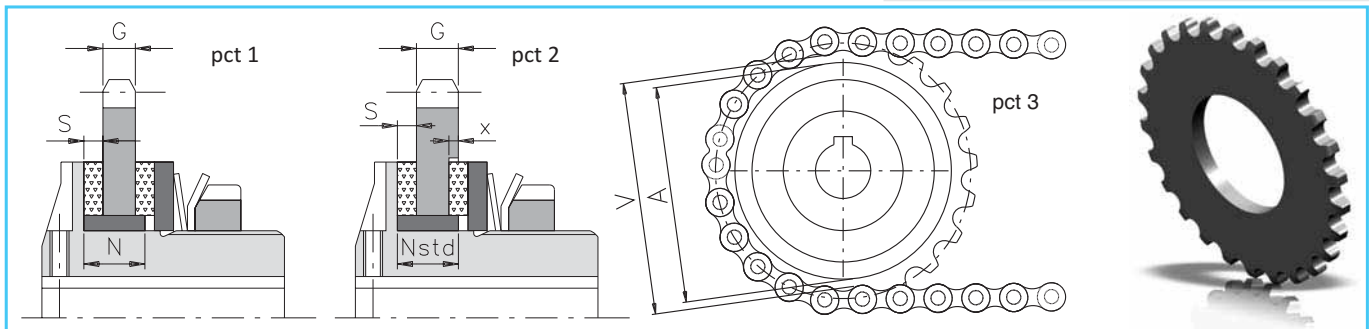

Size	P [in]	G [mm]	Z	dp [mm]	S [mm]	N Std [mm]	A [mm]	V [mm]	Code for single plate wheel		
									DF DSF/TF/AP	DF/SI DSF/TF/AP/SI	EDF/F
00.25	3/8"	5,1	12	36,80	2	5,5	25	28	580419851P05	-	-
00.38	3/8"	5,1	16	48,82	2,5	8	38	41	580406900P05	-	580406951P05
0.50	3/8"	5,1	20	60,89	3	10	50	53	580406400P05	-	580406451P05
			22	66,93					580406500P05	-	580406551P05
			16	65,10					580406700P05	-	-
1.70	3/8"	5,1	28	85,07	4	15	70	73	580404000P05	-	-
			7,0	89,24					580403700P05	580407700P20	580403751P05
			8,9	96,45					580404200P05	-	-
2.90	1/2" x 5/16"	7,0	26	105,36	4	17	90	94	580404700P05	-	-
			8,9	111,55					580404600P05	-	-
			10,9	109,71					580440100P05	580442100P20	580440151P05
3.115	5/8"	8,9	38	192,24	4	21	115	119	580404800P05	-	-
			10,9	139,9					580404900P05	-	-
			16,0	138,22					580440200P05	580442200P20	580440200P05
4.140	1"	16,0	20	162,38	5	25	140	144	580440300P05	580442300P20	580440351P05
			24	194,59					580440400P05	580442400P20	-
5.170	1" 1/4	18,3	20	202,98	5	28	170	175	580417200P05	-	-
			26	263,40					580406200P05	580407600P20	-
7.240	1" 1/4	18,3	28	283,56	5	35	240	245	580406300P05	580407700P20	-
8.300	1" 1/2	23,8	28	340,27	6	40	300	306	580407000P05	580407300P20	-
9.340	1" 1/2	23,8	32	388,69	6	40	340	355	580407100P05	580407400P20	-
10.400	1" 1/2	23,8	36	437,16	6	42	400	403	580407200P05	580407500P20	-

## TORQUE TRANSMISSION

Torque transmission [Nm] relevant to the springs configuration									
Size	A1S1 )	A2S2 )	A3S3 )	A1M1 )	A1G1 )	A2G2 )	A3G3 )	ST ( ) ) )	SQ ( ) ) )
00.25	1 - 8	2 - 12	2 - 20						
00.38	1 - 14	8 - 22	15 - 34						
0.50	2 - 12				4 - 40	17 - 70	23 - 100	1,5 - 9	
1.70	6 - 18			9 - 35	19 - 60	34 - 120	60 - 210	2 - 34	2 - 60
2.90	10 - 36			13 - 105	74 - 140	90 - 280	185 - 450	5 - 56	3 - 70
3.115	26 - 100			65 - 280	120 - 360	207 - 700	210 - 950	10 - 130	25 - 160
4.140	80 - 140			100 - 240	180 - 550	260 - 950	390 - 1200		
5.170				120 - 280	160 - 700	300 - 1450	1000 - 2600		

Size	A4M1 ( )	A4G1 ( )	A4G2 ( )						
6.205	300 - 1200	500 - 2400	1000 - 4800						
7.240	500 - 2000	1000 - 4000	2000 - 8000						
8.300	800 - 3500	1500 - 7000	3000 - 14000						
9.340	1000 - 4500	2000 - 9000	4000 - 18000						
10.400	1500 - 5000	3000 - 11000	5000 - 23000						

## ORDER EXAMPLE

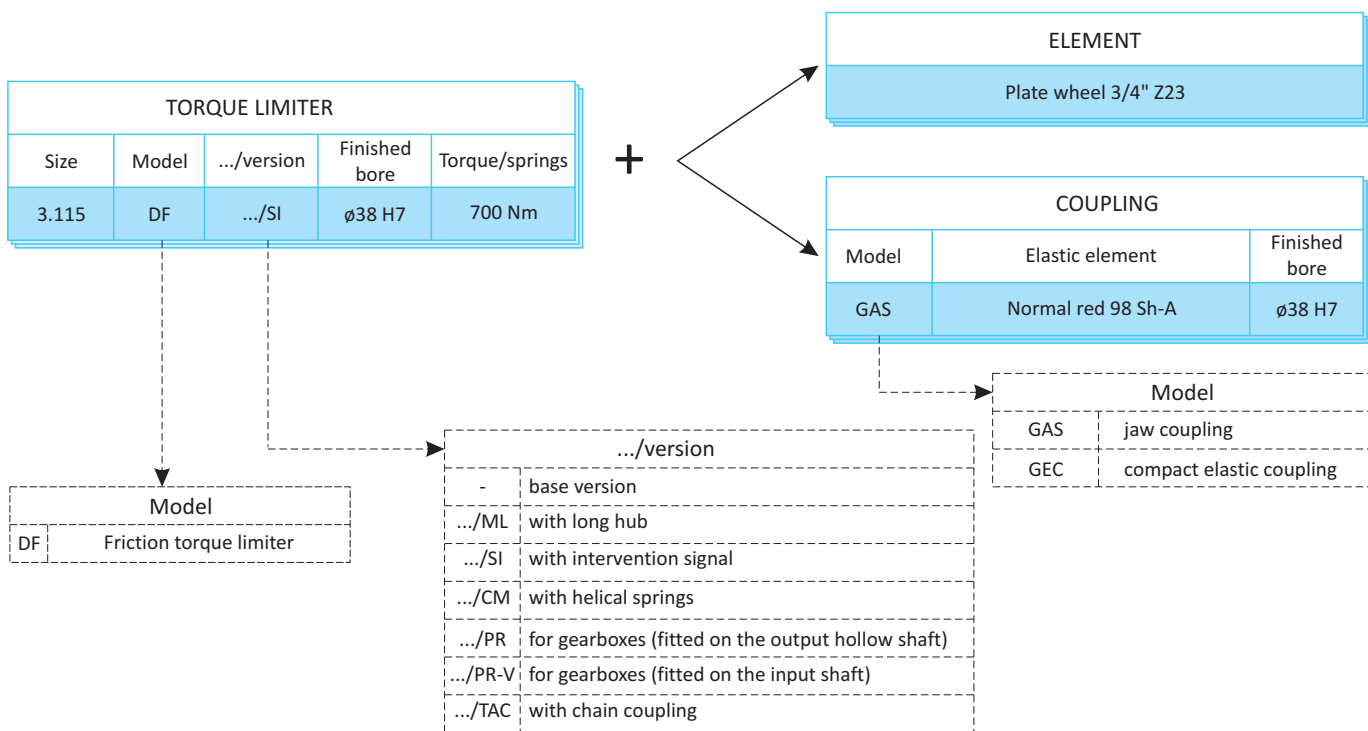

# ECONOMIC BALL TORQUE LIMITER “EDF/F”: introduction



- Reduced torsional backlash by ball drive.
- Maintenance free for long lasting, high reliability.
- Possibility to add a microswitch or proximity for transmission disconnection.
- Version with 360° phase re-engagement available.
- Mounting of the transmission gear inside the device similar to the friction torque models.
- The innovative regulation of the nominal torque by measuring the "H" dimension allows for immediate coupling calibration.
- Model available only with finished bore.
- Torque range from 7,5 to 1450 Nm and max. finished bore ø55 mm.

### ON REQUEST

- Model with flange and personalized connections: EDF/F/F.
- Connections with bore, locking assembly or other locking systems available.
- Personalized version with re-engagement in phase at 30°, 45°, 60°, 90°..

	EDF/F/C: basic model for drive with platewheels, pulleys, with parallel shafts	from 7,5 to 1450 Nm max. bore ø55 mm	Page 15
	EDF/F/TAC: in-line shaft connection, simple and economic.	from 7,5 to 1450 Nm max. bore ø80 mm	Page 15

## MAIN APPLICATIONS

- Filling machines, metal chip conveyors.
- Automatic conveyor belts.
- Winches.

## ADVANTAGES AND BENEFITS

- Protects the product from damage or wrong positioning.
- Protects the product from deformation.
- Protects conveyor belts in case of product collisions.

## TORQUE TRANSMISSION

Torque transmission [Nm] relevant to the springs configuration						
Side	A3S1 )()	A4S1 )()	A4S2 )()	A3M1 )()	A4M1 )()	A3G1 )()
00.38	7,5 - 15		14,5 - 30			
0.50		8 - 24			15 - 40	40 - 70
1.70		15 - 45		30 - 100		60 - 155
2.90	35 - 110			95 - 235		205 - 320
3.115		50 - 155		145 - 385		215 - 580
4.140	180 - 345			320 - 620		550 - 1450

## ORDER EXAMPLE

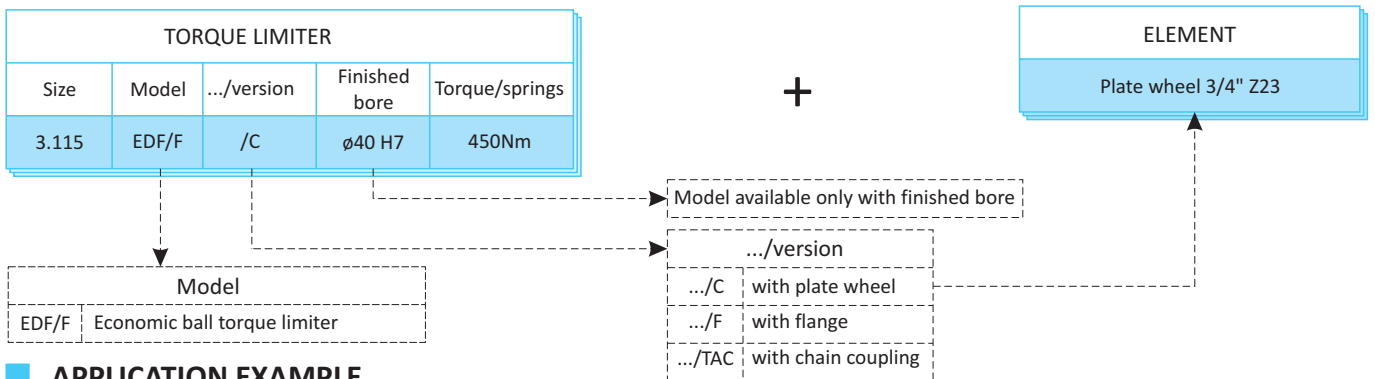

## APPLICATION EXAMPLE

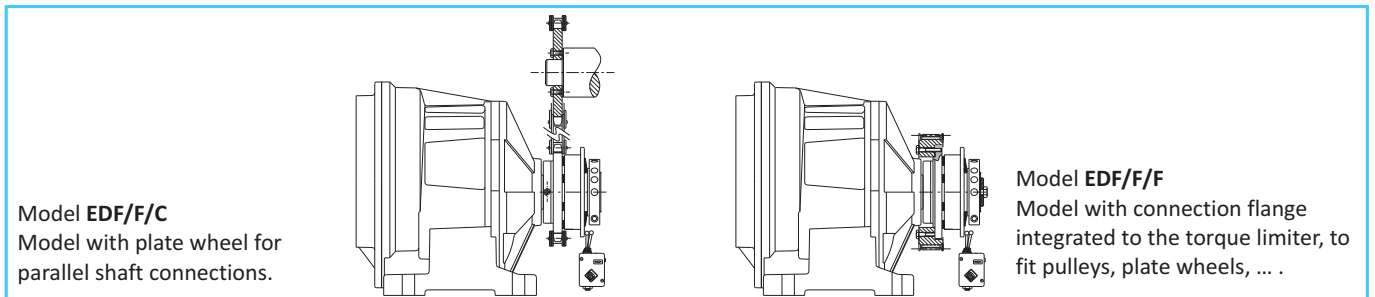

## EDF/F (economic ball torque limiter): technical data

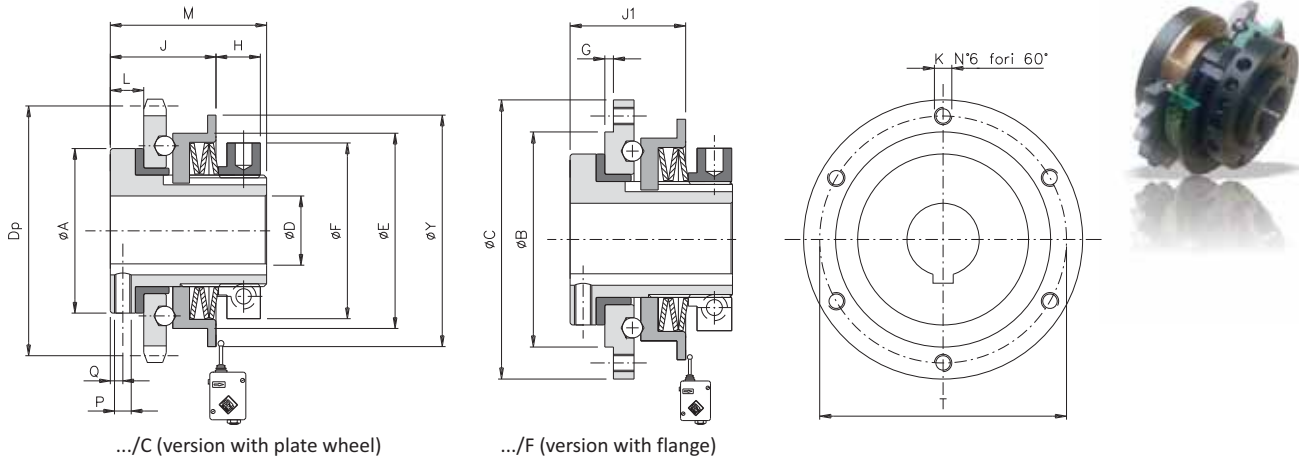

.../C (version with plate wheel)

.../F (version with flange)

### DIMENSIONS AND TECHNICAL DETAILS

Size	Torque [Nm]	A	B h7	C	D H7		E	F	G	J1	K	L	M	P	Q	T	Y	Standard platewheel			Max. speed [Rpm]	Weight [Kg]
					Pilot bore	max.												lead	Dp	J		
00.38	7,5 - 30	30	35	52	-	12	38	35	1	21	M4	6	33	M3	2	44	48	3/8" Z16	48,82	20,5	1900	0,2
0.50	8 - 70	40	50	68	-	20	50	42	1,5	26	M5	8	42	M4	3	58	63	3/8" Z20	60,89	24,5	1400	0,5
1.70	15 - 155	59	65	90	-	25	70	63	2	36	M5	11	55	M6	4	80	83	1/2" Z22	89,24	34	1200	1,3
2.90	35 - 320	72	85	112	-	38	90	82	2	40	M6	12	61	M6	4,5	100	103	3/4" Z18	109,71	40	1000	2,4
3.115	50 - 580	89	110	140	18	45	115	104	2	51	M8	14	71	M6	5,5	125	128	1" Z17	138,22	53	800	4,1
4.140	180 - 1450	104	135	174	24	55	140	128	2	57,5	M10	15	86	M8	5,5	155	153	1" Z20	162,38	58,5	650	6,9

## .../TAC (version with chain coupling): technical data

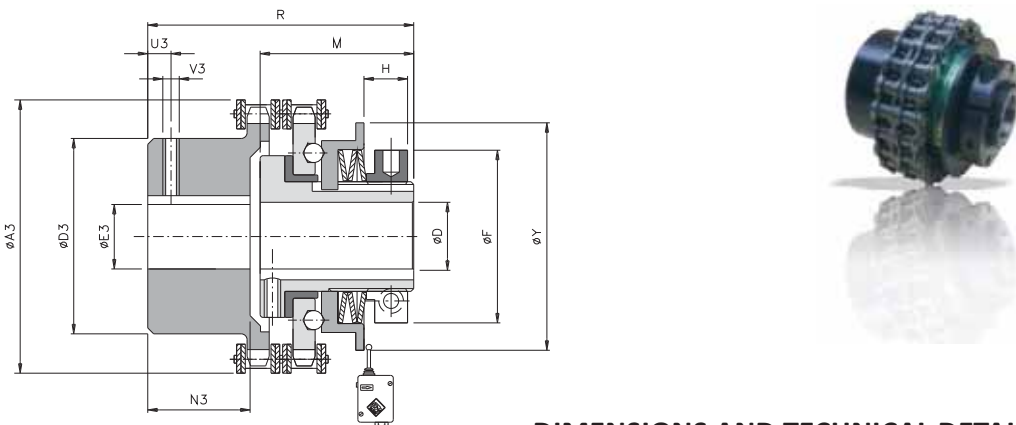

### DIMENSIONS AND TECHNICAL DETAILS

Size	Torque [Nm]	D H7		F	Y	M	R	A3	D3	E3 H7		N3	U3	V3	Max. speed [Rpm]	Weight [Kg]
		Pilot bore	max.							Pilot bore	max.					
00.38	7,5 - 30	-	12	35	48	33	60	58	37	10	20	20	5	M3	1900	0,6
0.50	8 - 70	-	20	42	63	42	67	75	50	12	28	19	8	M4	1400	1,0
1.70	15 - 155	-	25	63	83	55	91	101	70	16	38	29	8	M4	1200	2,9
2.90	35 - 320	-	38	82	103	61	107	126	89	20	55	38	12	M6	1000	6,1
3.115	50 - 580	18	45	104	128	71	136	159	112	20	70	56,5	12	M6	800	9,5
4.140	180 - 1450	24	55	128	153	86	156	184	130	28	80	59,5	15	M8	650	20

### NOTES

- ⊗ Technical details: data is relevant to the whole group (EDF/F – EDF/F/TAC).
- ⊗ Technical details: weights are relevant to the whole group with pilot bore (EDF/F – EDF/F/TAC).

# BALL AND ROLLER TORQUE LIMITERS “DSS or DSR”: introduction



- ⊙ Precise torque setting by adjusting the radially balanced locking nut.
- ⊙ The innovative regulation of the nominal torque by measuring the “H” dimension allows for immediate coupling calibration.
- ⊙ Equidistant re-engagement in phase or at 360°.
- ⊙ Available with electromechanical switch / proximity for the transmission disconnection.
- ⊙ Immediate intervention for an improved reaction compared to electronic systems.
- ⊙ Maintenance-free for long lasting high reliability.
- ⊙ Suitable for oily and wet environments.

### ON REQUEST

- ⊙ Complete with transmission gear, fully turned and mounted (plate wheel, pulley, gear pair).
- ⊙ Possibility to use helical springs for low intervention torques.
- ⊙ Connections with bore and keyway, locking assembly possible.
- ⊙ Version with personalized re-engagement in phase 30°, 45°, 60°, 90°... possible.

	DSS or DSR: basic model for coupling connections.	from 2,5 to 12000 Nm max. bore $\varnothing$ 120 mm	Page 19	Models and versions described on pages 17 and 18
	.../FS: for the assembly of simple transmission elements.	from 2,5 to 12000 Nm max. bore $\varnothing$ 120 mm	Page 20	
	DSR/F/RF: mechanical model with free rotation and phase 360°.	from 25 to 1460 Nm max. bore $\varnothing$ 68 mm	Page 21	
	... + GTR: connection with torsionally rigid coupling.	from 2,5 to 2800 Nm max. bore $\varnothing$ 90 mm	Page 22	
	... + GAS: connection with elastic coupling with high misalignments.	from 2,5 to 2800 Nm max. bore $\varnothing$ 110 mm	Page 22	
	... + GEC: connection with elastic coupling with low misalignments.	from 2,5 to 12000 Nm max. bore $\varnothing$ 180 mm	Page 23	

## ■ MAIN APPLICATIONS

- ⊙ Packaging and wrapping machines.
- ⊙ Labelling machines.
- ⊙ Bottling machines.
- ⊙ Conveyors.

## ■ ADVANTAGES AND BENEFITS

- ⊙ Protects the gearbox from jamming due to foreign matters.
- ⊙ Protects packages from squashing and deforming.
- ⊙ Protects the product handling elements from accumulations.
- ⊙ Maintains the timing between driver and driven after an overload.

## ■ APPLICATION EXAMPLES

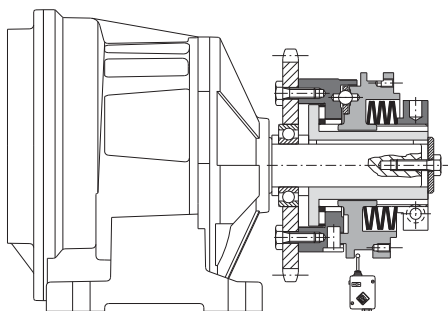

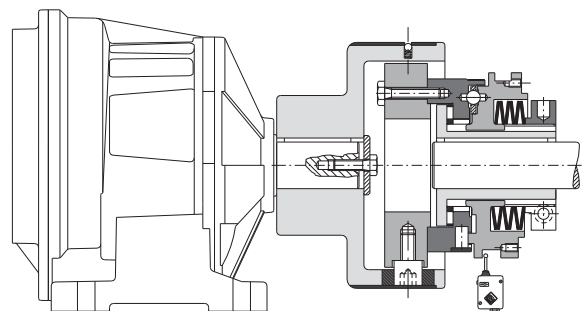

Model DSS or DSR drive element supported by bearing for parallel axes transmission.



Model DSS or DSR with compact elastic coupling GEC for coaxial shaft transmission.

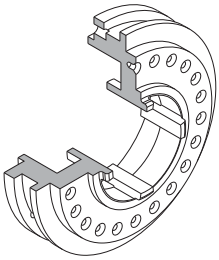
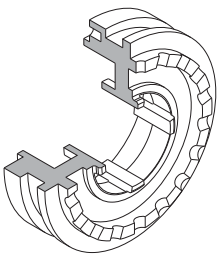
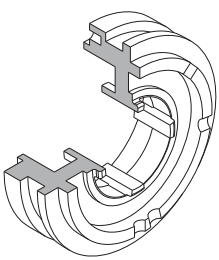

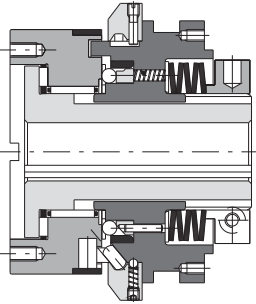
	<p><b>DSS: Ball torque limiter with optimum sensitivity in case of sudden torque variations</b></p> <ul style="list-style-type: none"> <li>Ball transmission.</li> <li>High sensitivity and immediate intervention in case of minimal torque variation.</li> <li>Equidistant automatic re-engagement.</li> <li>Torque range from 2,5 to 2050 Nm; max. bore <math>\varnothing</math>68 mm.</li> <li>Same intervention torque in both directions.</li> </ul>
	<p><b>DSR: Roller torque limiter for steady transmission at high torques and vibrations</b></p> <ul style="list-style-type: none"> <li>Roller transmission.</li> <li>Equidistant automatic re-engagement.</li> <li>High torque settings at reduced dimensions.</li> <li>Torque range from 10 to 12000 Nm; max. bore <math>\varnothing</math>120 mm.</li> <li>Same intervention torque in both directions.</li> </ul>
	<p><b>DSR/F: Roller phase torque limiter, synchronised connection between input and output.</b></p> <ul style="list-style-type: none"> <li>Roller transmission.</li> <li>Optimized roller arrangement (patented) with perfect stability and 3 point contact during the whole rotation period.</li> <li>and after disengagement.</li> <li>Automatic re-engagement in phase 360° or personalized (30°, 45°, 60°, 90°, 120°, ...)</li> <li>High torque settings at reduced dimensions.</li> <li>Torque range from 10 to 12000 Nm; max. bore <math>\varnothing</math>120 mm.</li> </ul> 
	<p><b>DSR/F/RF: roller phase torque limiter free rotation after disengagement, until inertial forces are stopped</b></p> <ul style="list-style-type: none"> <li>Roller transmission.</li> <li>Free rotation after disengagement.</li> <li>one engagement in 360°.</li> <li>Same intervention torque in both directions.</li> <li>Torque range from 2,5 to 2800 Nm; max. bore <math>\varnothing</math>68 mm.</li> </ul>

### NUMBER OF RE-ENGAGEMENT IN 360°

Model	Size							
	0.56	1.90	2.110	3.130	4.160	5.194	6.240	7.280
DSS	24	22	20	20	22	15	-	-
DSR	18	18	16	16	16	24	24	24
DSR/F	1	1	1	1	1	1	1	1
DSR/F/RF	-	1	1	1	1	1	-	-

## VERSIONS

Example: DSR/F/SMO DX

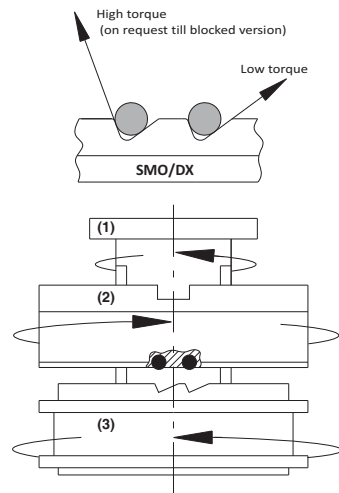

### DSR/SMO: Torque limiter with different disengagement torques from clockwise to anti-clockwise rotation.

- Different intervention torques in the two rotation directions.
- Locking of one direction possible.
- Roller transmission with automatic re-engagement.
- Available with equidistant re-engagement or personalized angular phases.
- Torque range from 10 to 12000 Nm; max. bore  $\varnothing$ 120 mm.

### DSR/SMO and DSR/F/SMO: determination of the rotation direction

To allow our engineers to select the correct direction "SX" or "DX" for your application, we require a drawing showing:

- 1) How the unit will be mounted on to the shaft (orientation).
- 2) The direction of rotation.
- 3) In which direction the high/low torque is required.



Example: DSR/F/AM DX

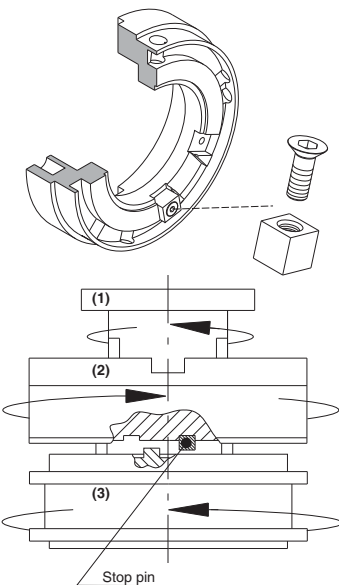

### DSR/F/AM: DSR/F/AM: Torque limiter with mechanical disconnection to maintain the timing between driver and driven

- Stop pin resists 4 times the maximum torque.
- 345° rotation after disengagement allows the cancellation of the residual torque before the device stops.
- Maintains the timing and re-engages in the same position.
- High torque settings at reduced dimensions.
- Torque range from 10 to 2800 Nm; max. bore  $\varnothing$ 68 mm.

### DSR/F/AM: determination of the rotation direction

To allow our engineers to select the correct direction "SX" or "DX" for your application, we require a drawing showing:

- 1) How the unit will be mounted on to the shaft (orientation).
- 2) The direction of rotation.
- 3) Confirm which drive will continue to rotate after the overload, the shaft or platewheel, pulley, etc.

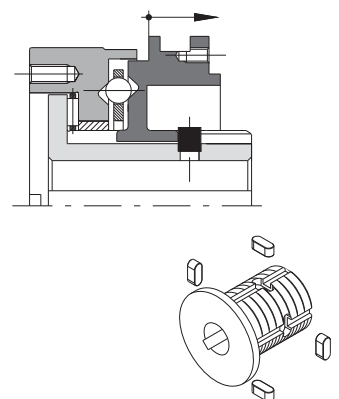

### .../TAS: Torque limiter with stop pins

- Complete disconnection prevented.
- Minimum movement of the mobile base for an electrical signal to stop transmission.
- Roller or ball transmission.
- Torque range from 2,5 to 2800 Nm; max. bore  $\varnothing$ 68 mm.
- Suitable for applications where the drive must not be disconnected.

## DSS or DSR (ball or roller torque limiter): technical data

- ⊙ Basic model, connection with in-line shafts possible.
- ⊙ The assembly with helical springs allows a higher sensitivity in torque setting: .../CM.
- ⊙ Available with longer shaft for the assembly with transmission elements of large size : .../ML.
- ⊙ Available with anti-corrosive surface treatments.
- ⊙ Available with intervention signal ring.
- ⊙ Torque range from 2,5 to 12000 Nm; max. bore  $\varnothing$ 120 mm.

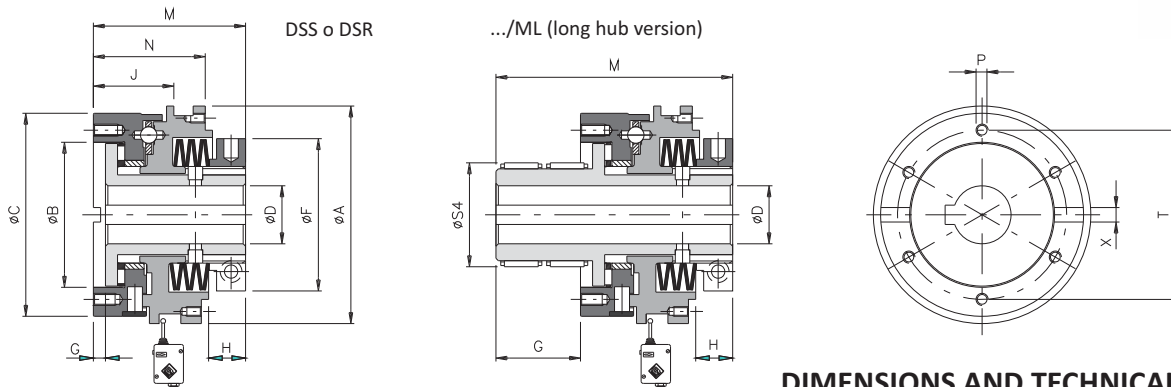

**DIMENSIONS AND TECHNICAL DETAILS**

Size	Mod.	Torque [Nm]	A	B H7	C	D H7		F	G		J	M		N	P	S4 h7		T	X	Max speed [Rpm]	Weight [Kg]	
						Grz	Max. /ML		/ML	/ML		Bushing	Bearing									
0.56	DSS DSR	2,5 - 32 10 - 75	56	41	56	-	20	20*	42	3,8	27,5	21,5 20	46	73,5	32 31	M5	33	33	48	6x3	4500 1500	0,6
1.90	DSS DSR	18 - 155 30 - 350	90	60	84	-	28	28*	63	5	35	33,5 27,5	63	98	47 45	M5	45	43	70	6x3	3000 1000	1,9
2.110	DSS DSR	30 - 290 60 - 620	110	78	104	-	40	38	82	6	38	39 36,5	76	114	54 52	M6	60	55	89	8x3,5	2500 800	3,6
3.130	DSS DSR	40 - 540 75 - 900	130	90,5	124	20	50	50*	104	6	47	47 45	88	135	65 64	M8	72	70	105	10x4	2000 700	6,0
4.160	DSS DSR	70 - 1200 160 - 1800	160	105	148	25	58	58*	128	8	53	58,5 54,5	107	160	76,5	M10	85	83	125	12x4	1600 550	10,7
5.194	DSS DSR	125 - 2050 275 - 2800	194	120,5	176	28	68	68*	157	6,5	57,5	65 64,5	124,5	182	88 88,5	M12	98	98	155	14x4,6	1300 400	18,2

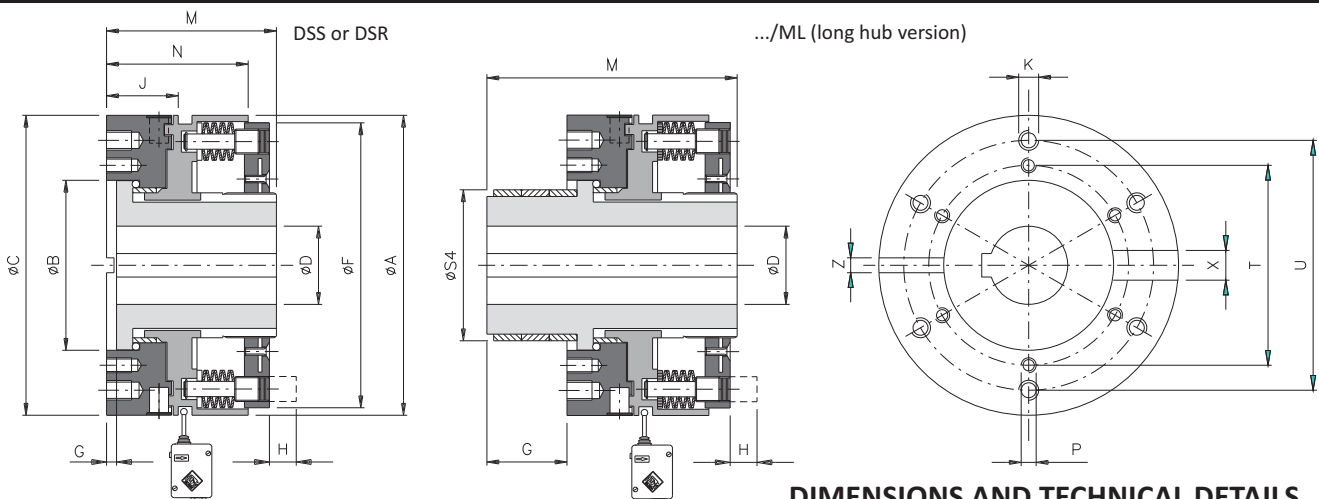

**DIMENSIONS AND TECHNICAL DETAILS**

Size	Mod.	Torque [Nm]	A	B H7	C	D H7		F	G		J	K	M		N	P	S4 h7		T	U	Z	X	Max speed [Rpm]	Weight [Kg]
						Pilot bore	max.		/ML	/ML			Bushing	Bearing										
6.240	DSR	1600 - 8000	240	136	240	50	90	227	8	64	57	M 16	141	205	116	M12	118	160	200	16x5,1	18x5,1	300	30,6	
7.280	DSR	2000 - 12000	280	198	280	50	120	262,5	8	82	82	-	200	282	159	M20	168	230	-	-	20x6,1	200	79,0	

**NOTE**

⊗ Technical details: weights are relevant to the pilot bore torque limiter (DSS or DSR).

## .../FS (version with supporting flange): technical data



- Basic model with flange for parallel shafts.
- The assembly with helical springs allows a higher sensitivity in torque setting: .../FS/CM.
- Available with anti-corrosive surface treatments.
- Available with /FIR flange for reduced axial dimensions.
- Available with /FAV flange for cardan coupling connection.
- Torque range from 2,5 to 12000 Nm; max. bore  $\varnothing$ 120 mm.

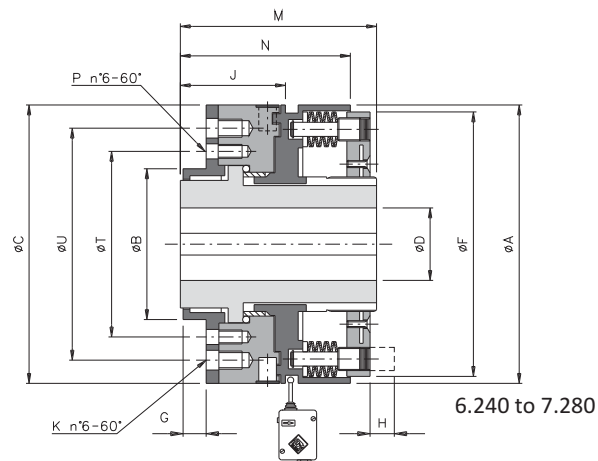
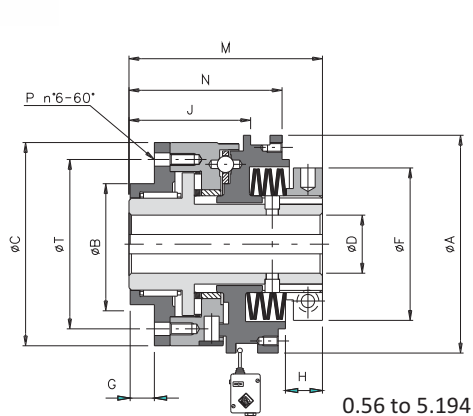

### DIMENSIONS AND TECHNICAL DETAILS

Size	Mod.	Torque [Nm]	A	B H7	C	D H7		F	G	J	K	M	N	P	T	U	Max. speed [Rpm]	Weight [Kg]
						Pilot bore	max.											
0.56	DSS DSR	2,5 - 32 10 - 75	56	38	56	-	20*	42	7,5	34,5 33	-	59	45 44	M5	48	-	4500 1500	0,7
1.90	DSS DSR	18 - 155 30 - 350	90	50	84	-	28*	63	9,5	50,5 44,5	-	80	64 62	M5	70	-	3000 1000	2,4
2.110	DSS DSR	30 - 290 60 - 620	110	60	104	-	38	82	11,5	56 53,5	-	93	71 69	M6	89	-	2500 800	4,4
3.130	DSS DSR	40 - 540 75 - 900	130	80	124	20	50*	104	11,5	65 63	-	106	83 82	M8	105	-	2000 700	7,1
4.160	DSS DSR	70 - 1200 160 - 1800	160	100	148	25	58*	128	15,5	83,5 79,5	-	132	101,5	M10	125	-	1600 550	13,0
5.194	DSS DSR	125 - 2050 275 - 2800	194	120	176	28	68*	157	17,5	92,5 92	-	152	115,5 116	M12	155	-	1300 400	21,6
6.240	DSR	1600 - 8000	240	130	240	50	90	227	18	83,5	M16	170	142,5	M12	160	200	300	37,5
7.280	DSR	2000 - 12000	280	190	280	50	120	262,5	30	130	-	248	207	M20	230	-	200	90,5

\* with reduced keyway UNI7510.

### OTHER FLANGE TYPES

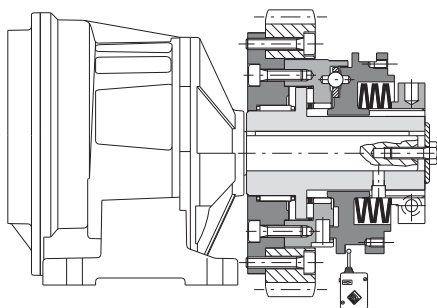

Version .../FIR with reduced dimension flange, designed to reduce to the minimum the axial dimensions.

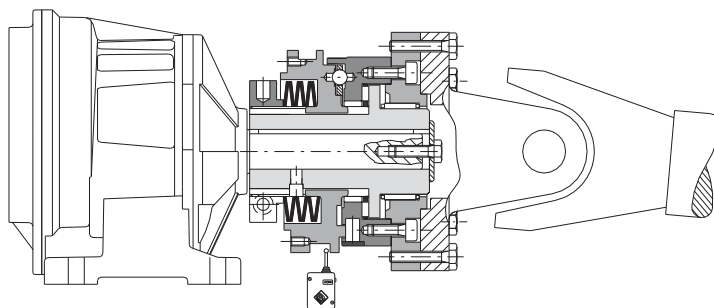

Version .../FAV with various flange dimensions to connect cardan shafts to the torque limiter.

### NOTE

- ⊗ Technical details: weights are relevant to the pilot bore torque limiter (.../FS).

## DSR/F/RF (roller phase torque limiter free rotation): technical data

- Simple manual engagement without any specific equipment.
- Suitable for assembly in drive trains with high inertia.
- Available with longer shaft for assembly with transmission elements of large size: .../ML.
- Available with supporting flange for assembly of the drive element directly on the hub: .../FS.
- Model available only with finished bore.
- Torque range from 25 to 1460 Nm; max. bore  $\varnothing 68$  mm.

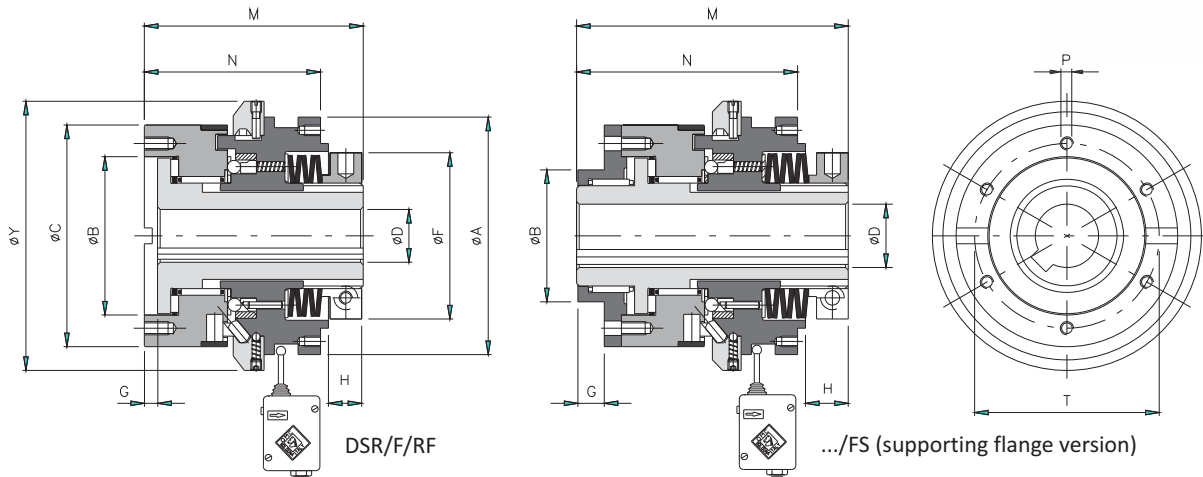

### DIMENSIONS AND TECHNICAL DETAILS

Size	Torque [Nm]	A	B (H7 - h7)		C	D H7			F	G		M		N		P	T	Y	Max. speed [Rpm]	Weight [Kg]	
			/FS			Pilot bore	max.	/FS		/FS	/FS	/FS	/FS	/FS	/FS					/FS	
1.90	25 - 155	90	60	50	84	-	28	28*	63	5	10	86	103	67	84	M5	70	102	1500	3	3,5
2.110	45 - 360	110	78	60	104	-	40	38	82	4	10,5	93	112	69	86	M6	89	128	1100	4,7	5,5
3.130	80 - 450	130	90,5	80	124	20	50	50*	104	4	11	108	126	83	101	M8	105	146	900	7,8	9,3
4.160	125 - 1060	160	105	100	148	25	58	58*	128	8	16	138	163	109	134	M10	125	176	700	14,5	17,2
5.194	160 - 1460	194	120,5	120	176	28	68	68*	157	5,5	18	154	181	110	154	M12	155	205	550	22,9	26,3

\* with reduced keyway UNI7510.

### APPLICATION EXAMPLES

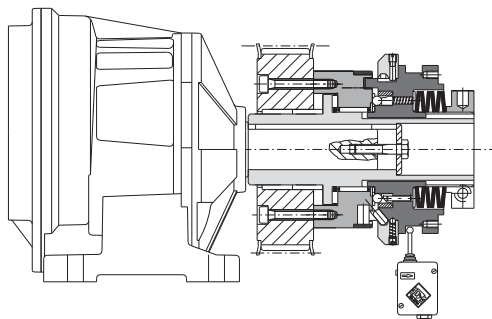

Version .../ML with drive element supported by bronze bushing for parallel shafts transmissions with elements of large size.

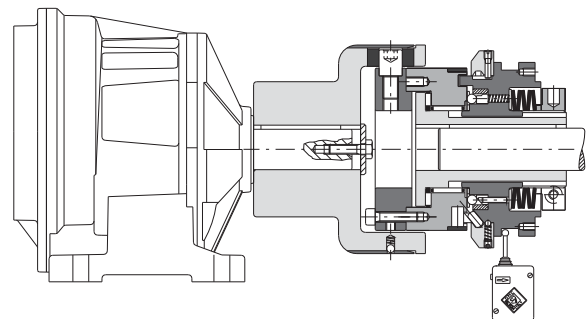

Model DSR/F/RF with compact elastic coupling GEC for coaxial shafts connections.

### NOTE

- Technical details: weights are relevant to the pilot bore torque limiter (DSR/F/RF).

## ... + GTR (model with torsionally rigid disc coupling): technical data

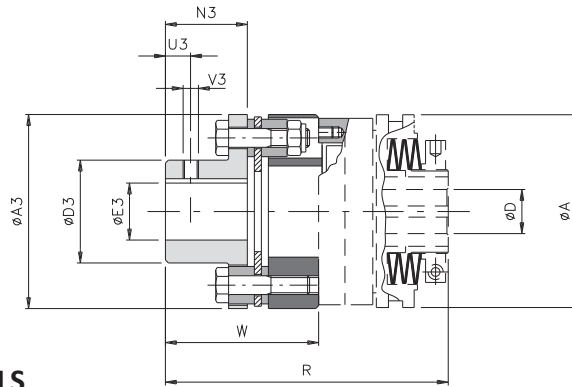

### DIMENSIONS AND TECHNICAL DETAILS

Size		Torque [Nm]		A3	D3	E3 H7 max.	N3	U3	V3	A	D H7		R	W	Misalignments		Stiffness	Max. speed [Rpm]		Weight [Kg]
DSS DSR	GTR	Nom	Max								pilot bore	max.			Angular $\alpha$ [°]	Axial X [mm]	[Nm/rad·10 <sup>3</sup> ]	DSS	DSR	
0.56	0	40	80	78	45	32	29	10	M5	56	-	20	105	59	1°	1,40	80	4500	1500	1,4
1.90	2	150	300	92	53	38	42	10	M5	90	-	28	137	74	0° 45'	0,95	156	3000	1000	2,1
2.110	3	300	600	112	65	45	46	15	M8	110	-	40	161	85	0° 45'	1,25	415	2500	800	3,9
3.130	4	700	1400	136	75	52	56	15	M8	130	20	50	186	98	0° 45'	1,45	970	2000	700	5,8
4.160	5	1100	2200	162	92	65	66	20	M8	160	25	58	223	116,5	0° 45'	1,65	1846	1600	550	10,8
5.194	7	2600	5200	206	130	90	92	20	M10	194	28	68	270	145,5	0° 45'	2,25	3511	1300	400	21,9

## ... + GAS (model with jaw elastic coupling): technical data

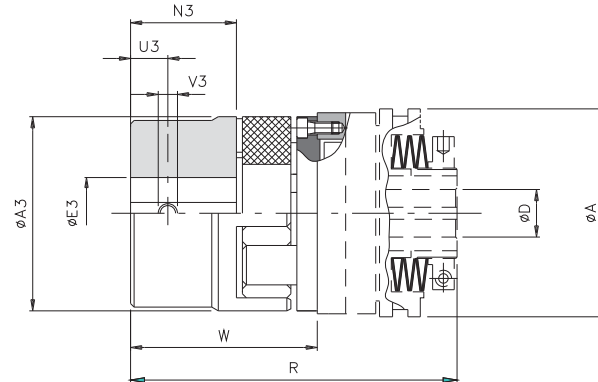

### DIMENSIONS AND TECHNICAL DETAILS

Size		Torque [Nm]		A3	E3 H7 max	N3	P3	U3	V3	A	D H7		R	W	Misalignments			Max. speed [Rpm]		Weight [Kg]
DSS DSR	GAS	Nom.	Max.								Pilot bore	max.			Angular $\alpha$ [°]	Axial X [mm]	Radial K [mm]	DSS	DSR	
0.56	0	60	120	55	35	30	18	10	M5	56	-	20	103	57	1° 18'	1	0,8	4500	1500	0,8
1.90	2	325	650	80	48	45	24	15	M8	90	-	28	141	78	1° 18'	1,4	1	3000	1000	3,7
2.110	4	525	1050	105	62	56	28	20	M8	110	-	40	171	95	1° 18'	1,7	1,4	2500	800	5,2
3.130	5	685	1370	120	74	65	30	20	M10	130	20	50	198	110	1° 18'	1,8	1,4	2000	700	9,1
4.160	7	1465	2930	160	95	85	40	25	M10	160	25	58	249	142	1° 18'	2,5	1,8	1600	550	17,9
5.194	8	3600	7200	200	110	100	45	30	M12	194	28	68	288,5	164	1° 18'	2,8	1,8	1300	400	29,5

### NOTES

- ⊗ Technical details: details are relevant to only for the coupling (GTR-GAS), for torque limiter details see on page 19.
- ⊗ Technical details: weights are relevant to only for the coupling (GTR-GAS) pilot bore.

## ... + GEC (model with compact elastic coupling): technical data

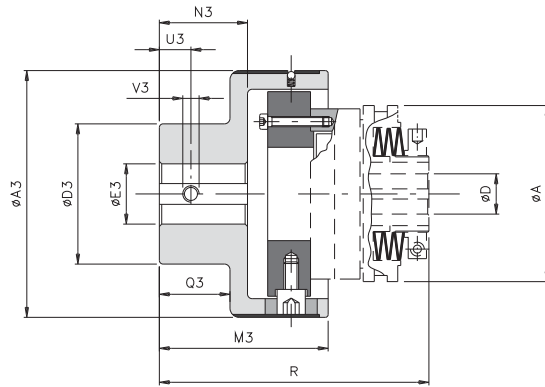

### DIMENSIONS

Size		Torque [Nm]		A3	D3	E3 H7		M3	N3	Q3	U3	V3	A	D H7		R
DSS or DSR	GEC	Nom.	Max.			pilot bore	max.							pilot bore	max.	
0.56	0	70	110	78	50	10	28	63,5	32	28	8	M4	56	-	20	100,5
1.90	1	280	420	108	70	12	38	89	49	44	12	M6	90	-	28	142
2.110	2	570	860	130	80	15	45	111	65	59	15	M8	110	-	40	177
3.130	3	980	1500	161	100	15	60	140	85	77	15	M8	130	20	50	215
4.160	4	2340	3600	206	120	20	70	168	105	97	20	M10	160	25	58	261
5.194	5	3880	5800	239	135	30	80	201	130	120	20	M10	194	28	68	309,5
6.240	6	15000	20000	315	215	40	150	260	165	150	25	M12	240	50	90	381
7.280	7	30000	35000	364	240	40	180	310	205	185	25	M12	280	50	120	485

### TECHNICAL DETAILS

Size		Misalignments							Max. speed [Rpm]		Weight [Kg]
DSS DSR	GEC	Angular $\alpha$ [°]		Axial X [mm]		Radial K [mm]		Torsional $\gamma$ [°]	DSS	DSR	
		continuous	intermittent	continuous	intermittent	continuous	intermittent				
0.56	0	1°	1° 30'	± 0,7	± 1,5	0,5	0,7	2°	4500	1500	1,2
1.90	1	0° 48'	1°	± 0,7	± 1,5	0,5	0,7	2°	3000	1000	3,5
2.110	2	0° 36'	0° 48'	± 0,7	± 1,5	0,6	0,7	1° 45'	2500	800	6,2
3.130	3	0° 30'	0° 42'	± 0,8	± 1,6	0,6	0,8	1° 15'	2000	700	11,5
4.160	4	0° 24'	0° 30'	± 0,8	± 1,6	0,6	0,8	1°	1600	550	20,8
5.194	5	0° 24'	0° 30'	± 0,8	± 1,6	0,6	0,8	1°	1300	400	32,0
6.240	6	0° 24'	0° 30'	± 0,8	± 1,6	0,6	0,8	1°	-	300	91,3
7.280	7	0° 24'	0° 30'	± 0,8	± 1,6	0,6	0,8	1°	-	200	173,9

### OTHER COUPLINGS

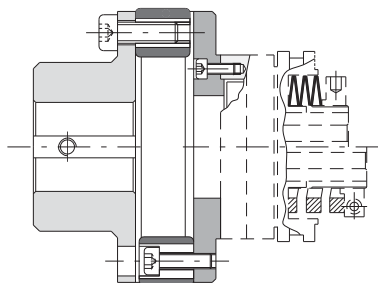

Model DSS or DSR with elastic coupling GF to absorb high torsional vibrations and for fast substitution of the elastic element.

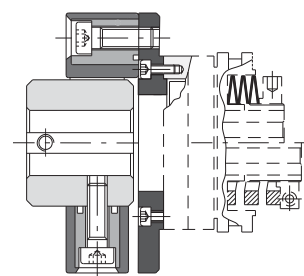









Model DSS or DSR with elastic coupling GGF to accept high misalignments.





### NOTES

- ⊗ **Technical details:** details are relevant to only for the coupling (GEC), for torque limiter details see on page 19.
- ⊗ **Technical details:** weights are relevant to only for the coupling (GEC) pilot bore.

# BALL OR ROLLER TORQUE LIMITER "DSS/DSR": additional information

## TORQUE TRANSMISSION

Torque transmitted [Nm] according to the spring configuration									
Size		A6S1 	A5M1 	A6M1 	A6M2 	A5G1 	A6G2 	ST 	SQ 
0.56	DSS	2,5 - 9,5		5,5 - 17,5	15 - 32			0,8 - 10,9	
	DSR	10 - 20		14 - 37	30 - 75			1,9 - 25,6	
1.90	DSS	18 - 48	24 - 55			35 - 90	55 - 155	2 - 40	5 - 90
	DSR	30 - 60	45 - 100			85 - 180	170 - 350	8 - 75	8 - 145
	DSR/F/RF	25 - 55	45 - 95			80 - 155			
2.110	DSS	30 - 60	35 - 100			55 - 160	80 - 290	9 - 50	12 - 100
	DSR	60 - 110	80 - 200			120 - 330	275 - 620	12 - 90	25 - 190
	DSR/F/RF	45 - 95	90 - 210			100 - 360			
3.130	DSS	40 - 100	50 - 225			70 - 300	130 - 540	12 - 135	24 - 190
	DSR	75 - 180	115 - 370			200 - 510	430 - 900	30 - 300	50 - 320
	DSR/F/RF	80 - 165	120 - 390			120 - 450			
4.160	DSS	70 - 200	90 - 325			150 - 690	300 - 1280		
	DSR	160 - 335	210 - 540			330 - 1040	750 - 1800		
	DSR/F/RF	125 - 310	190 - 550			310 - 1060			
5.194	DSS		125 - 420			360 - 1040	460 - 2050		
	DSR		275 - 660			540 - 1620	1050 - 2800		
	DSR/F/RF		160 - 630			430 - 1460			

Size		A12S1 	A14S1 	A15G1 	A16G1 				
6.240	DSR	1600 - 3800		2000 - 8000					
7.280	DSR		2000 - 5600		2500 - 12000				

## ORDER EXAMPLE

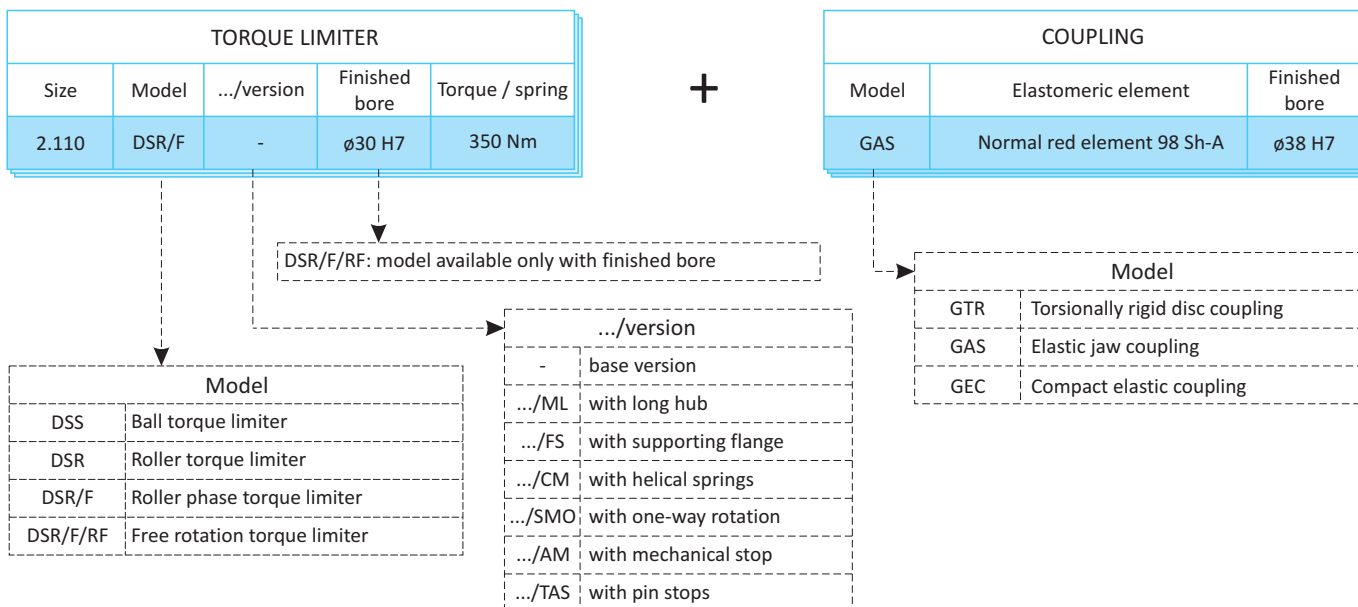



# BACKLASH FREE TORQUE LIMITER "DSS/SG": Introduction



- ⊙ Exact torque regulation through a balanced radial nut.
- ⊙ Innovative calibration system by quote "H" for an immediate calibration of the device.
- ⊙ Re-engagement in equidistant phase or 360°.
- ⊙ Maintenance free.
- ⊙ Possibility to add a microswitch / proximity to stop the motor drive.
- ⊙ Model available only with finished bore.
- ⊙ Drive component assembled and directly supported by a ball bearing.

### ON REQUEST

- ⊙ Complete with transmission component worked and assembled (plate wheel, pulley, gear,...)
- ⊙ Available in stainless steel for food and pharmaceutical environments.
- ⊙ Possibility to have a connection flange to the most common intermittent drive units.
- ⊙ Feasibility in personalized phase at 30°, 45°, 60°, 90°, ...

	.../P: base model for a high sensitivity in calibration.	from 1,5 to 750 Nm max. bore $\varnothing$ 50 mm	Page 26
	.../N: immediate disengagement when exceeding the calibration torque; low residual torque after the disengagement.	from 0,7 to 720 Nm max. bore $\varnothing$ 50 mm	Page 27
	... + GAS/CCE: connection by elastic coupling to accept high misalignments.	from 0,7 to 750 Nm max. bore $\varnothing$ 62 mm	Page 28
	... + GSF: Connection by bellows coupling for application with reduced inertia.	from 0,7 to 300 Nm max. bore $\varnothing$ 45 mm	Page 29

NEWS



DSS/SG in STAINLESS STEEL

- ⊙ Model without any backlash.
- ⊙ Same dimensions as the standard model, both in negative and positive versions.
- ⊙ Made in stainless steel at high resistance by suitable heat treatments.
- ⊙ High resistance to corrosion.
- ⊙ Suitable to food and/or pharmaceutical environments.

## APPLICATIONS

- ⊙ Packaging automatic machines.
- ⊙ Print machines.
- ⊙ CNC tool machines.
- ⊙ Index tables, filling machines, guiders.
- ⊙ Servomotors, slide guides.

## ADVANTAGES AND BENEFITS

- ⊙ To protect the product against faulty positioning on the rotating table.
- ⊙ To protect the indexing against overloading along the transmission.
- ⊙ To protect the drive from product jam.
- ⊙ To protect the operating units of machine tools against impacts.
- ⊙ To protect slides or servomotors against impact or limit stops.

## ASSEMBLY EXAMPLES

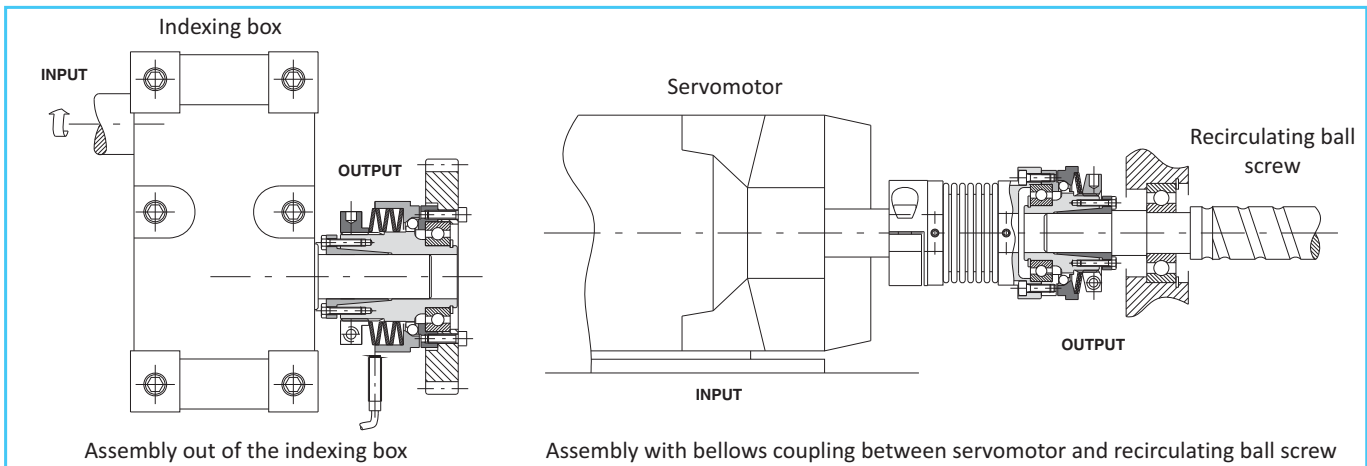

## .../P (positive version): technical data



- ⊙ Angular backlash free
- ⊙ Maximum simplicity of calibration by standard method.
- ⊙ Wide regulation torque range.
- ⊙ Very fast response times.
- ⊙ Available with extended hub to assemble wide drive components: .../ML.
- ⊙ Torque ranges: 1,5 – 750 Nm; max. bore:  $\varnothing$ 50 mm.

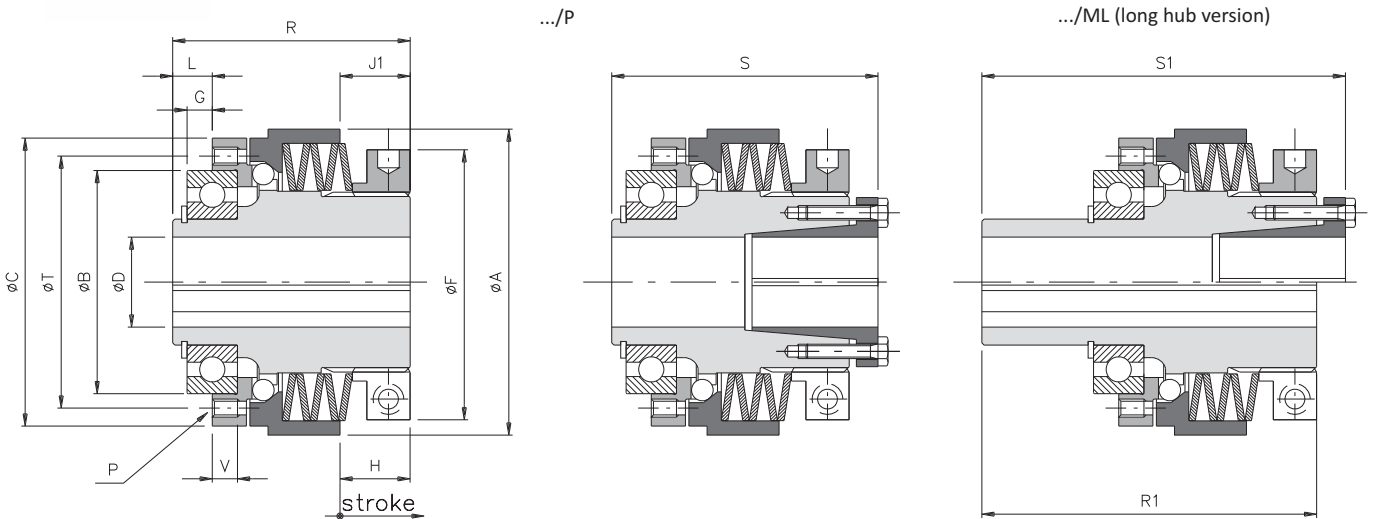

### DIMENSIONS

Size	Torque [Nm]	A	B h5	C	D H7 max.	F	G	L	J1	P	R	R1	S	S1	T	V	On request						
																	B h5	C	G	L	P	T	V
00.40	1,5 - 6,5	44	30	40	12	38	2	4,5	12	6xM3	36	-	40,5	-	35	5	-	-	-	-	-	-	-
00.47	5 - 20	50	37	47	17	42	2	5	14,5	6xM3	44	-	49,5	-	42	5	-	-	-	-	-	-	-
0.63	5 - 75	70	42	65	20	63	4	7	18	6xM5	56,5	81,5	63,5	88,5	48	7	47	-	5	8	8xM4	56	6
1.80	12 - 105	85	62	80	25	75	7	11	19,5	6xM5	66	98	74	106	70	7	-	-	-	-	8xM5	71	-
2.96	17 - 200	100	75	96	35*	82	9	14	20	6xM6	77,5	118,5	85,5	126,5	89	9	-	95	-	-	8xM6	85	-
3.116	40 - 415	115	90	115	42	104	8	14	16,5	6xM8	82	133	91	143	105	12	-	110	10	16	8xM6	100	10
4.138	75 - 750	139,5	100	138	50	128	6,5	14,5	18	6xM10	96	151	107	162	125	14	-	130	10	18	8xM8	116	11

### TECHNICAL DETAILS

Size	Stroke [mm]	Locking assemblies		Inertia [Kgm <sup>2</sup> ]			Max. speed [Rpm]	Weight [Kg]	
		Screws	Tightening torque [Nm]	Flange side	Nut side			keyway	locking assembly
					keyway	locking assemblies			
00.40	0,8	6xM3	1,5	0,000009	0,000043	0,000045	4000	0,3	0,3
00.47	1	6xM3	1,5	0,000015	0,00007	0,00008	4000	0,5	0,5
0.63	1,1	6xM4	3	0,00008	0,00033	0,00034	4000	1,1	1,1
1.80	1,3	8xM4	3	0,00029	0,00091	0,00094	3000	1,8	1,9
2.96	1,5	10xM4	3	0,00068	0,00213	0,00221	2500	3,2	3,4
3.116	2	8xM5	5	0,00129	0,00352	0,00372	2000	4,2	4,6
4.138	2,2	8xM6	7,5	0,00315	0,00853	0,00902	1200	7,5	8,1

### NOTES

- ⊗ **DH7\***: maximum diameter for finished bore with reduced keyway according to UNI7510.
- ⊗ **G\***: assembly tolerance +0.1.
- ⊗ **Technical details**: weights are relevant to the pilot bore; inertias refer to the maximum diameter for finished bore of the torque limiter (.../P).

- Angular backlash free with compact dimensions.
- Instantaneous torque transmission reduction when overloading.
- Free of residual torque after disengagement.
- Fastest response times and highest sensitivity.
- Available with extended hub to assemble wide drive components: .../ML.
- Torque range: 0,7 – 720 Nm; max. bore  $\phi 50$  mm.

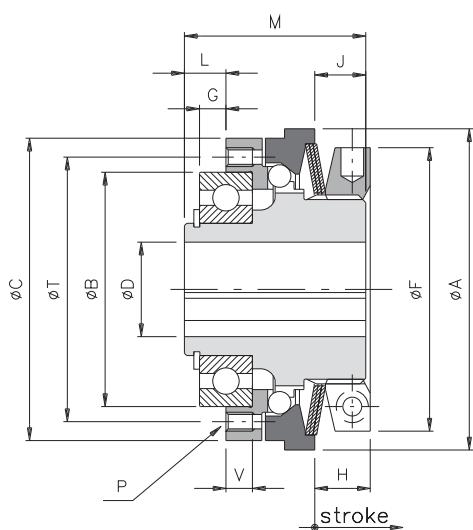

.../N

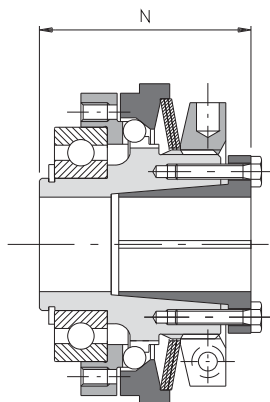

.../ML (long hub version)

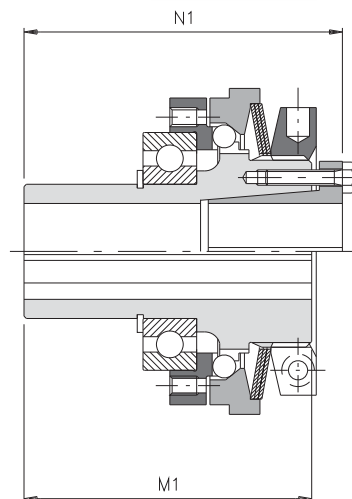

**DIMENSIONS**

Size	Torque [Nm]	A	B h5	C	DH7 max.	F	G	L	J	P	M	M1	N	N1	T	V	On request						
																	B h5	C	G	L	P	T	V
00.40	0,7 - 5	44	30	40	12	38	2	4,5	7	6xM3	24	-	28,5	-	35	5	-	-	-	-	-	-	-
00.47	2 - 15	50	37	47	17	42	2	5	8,5	6xM3	29	-	34,5	-	42	5	-	-	-	-	-	-	-
0.63	5 - 50	70	42	65	20	62	4	7	12	6xM5	40	65	47	72	48	7	47	-	5	8	8xM4	56	6
1.80	9 - 100	85	62	80	25	75	7	11	13,5	6xM5	48	80	56	88	70	7	-	-	-	-	8xM5	71	-
2.96	20 - 200	100	75	96	35*	82	9	14	16	6xM6	59	100	67	108	89	9	-	95	-	-	8xM6	85	-
3.116	35 - 415	115	90	115	42	97	8	14	17	6xM8	64	115	73	124	105	12	-	110	10	16	8xM6	100	10
4.138	75 - 720	135	100	138	50	117	6,5	14,5	20,5	6xM10	75	130	86	140	125	14	-	130	10	18	8xM8	116	11

**TECHNICAL DETAILS**

Size	Stroke [mm]	Locking assembly		Inertia [Kgm <sup>2</sup> ]			Max. speed [Rpm]	Weight [Kg]	
		Screws	tightening torque [Nm]	Flange side	Nut side			keyway	locking assembly
					keyway	locking assembly			
00.40	0,8	6xM3	1,5	0,00009	0,00002	0,00002	4000	0,2	0,2
00.47	1	6xM3	1,5	0,00015	0,00004	0,00004	4000	0,4	0,4
0.63	1,1	6xM4	3	0,00008	0,00027	0,00028	4000	0,9	0,9
1.80	1,3	8xM4	3	0,00029	0,00068	0,00071	3000	1,5	1,6
2.96	1,5	10xM4	3	0,00068	0,00151	0,00158	2500	2,8	3,0
3.116	2	8xM5	5	0,00129	0,00262	0,00282	2000	3,7	4,1
4.138	2,2	8xM6	7,5	0,00315	0,00633	0,00682	1200	6,7	7,3

**NOTES**

- DH7\*: maximum diameter for finished bore with reduced keyway according to UNI7510.
- G\*: assembly tolerance +0.1
- Technical details: the weights are relevant to the pilot bore; inertias refer to the maximum diameter for finished bore of the torque limiter (.../N).

## ... + GAS/CCE (model with jaw coupling and external locking assembly): technical data

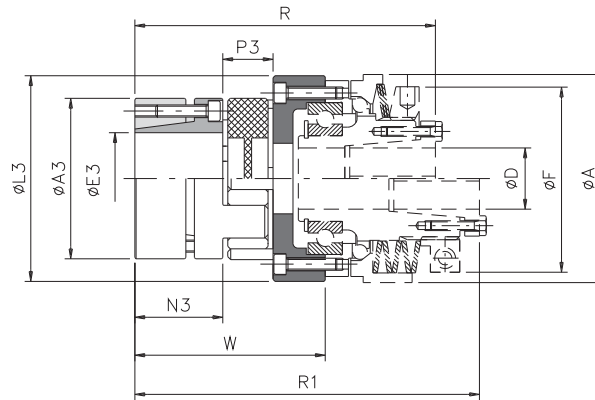

### DIMENSIONS

Size		Torque [Nm]		A3	E3 H7 max.	L3	N3	P3	A		D H7 max.	F		W	R	R1
SG	GAS CCE	Nom.	Max.						Positive	Negative		Positive	Negative			
00.47	00	17	34	40	20	47	25	16	44		17	42		53	82,5	117
0.63	0	60	120	55	28	65	30	18	70		20	63	62	63	102	118,5
1.80	1	160	320	65	38	84	35	20	85		25	75		74,5	119,5	137,5
2.96	2	325	650	80	48	102	45	24	100		35	82		88	146	164,5
3.116	3	450	900	95	55	122	50	26	115		42	104	97	95	159	178
4.138	4	525	1050	105	62	143	56	28	139,5	135	50	128	117	114	182	203

### TECHNICAL DETAILS

Size		Locking assemblies (CCE)		Misalignments			Rigidity			Inertia coupling side [Kgm <sup>2</sup> ]	Max. speed [Rpm]	Weight [Kg]
SG	GAS CCE	screws	Tightening torque [Nm]	Angular α [°]	Axial X [mm]	Radial K [mm]	Torsional [Nm/rad·10 <sup>3</sup> ]	Axial [mm]	Radial [mm]			
00.47	00	6xM4	3	0° 54'	1,2	0,06	980	2300	2000	0,00013	4000	0,4
0.63	0	4xM5	6	0° 54'	1,4	0,10	2350	6300	2620	0,00040	4000	0,7
1.80	1	8xM5	6	0° 54'	1,5	0,11	3620	10900	3490	0,00107	3000	1,7
2.96	2	8xM6	10	0° 54'	1,8	0,12	7850	21850	4650	0,00296	2500	1,9
3.116	3	4xM8	35	0° 54'	2,0	0,14	18600	47500	5760	0,00559	2000	3,2
4.138	4	4xM8	35	0° 54'	2,1	0,16	20400	50600	6400	0,01213	1200	5,8

### TRANSMITTABLE TORQUE WITH LOCKING ASSEMBLY

Size	Transmission torque [Nm] according to the ø finished bore [mm]																							
	10	11	14	15	16	17	18	19	20	22	24	25	28	30	32	35	38	40	42	45	48	50	55	60
00 (19/24)	48	53	67	72	77	81	86	91	96															
0 (24/28)				77	82	88	93	98	103	113	124	129	144											
1 (28/38)							186	196	206	227	247	258	289	309	330	361	392							
2 (38/45)									291	320	349	364	408	437	466	510	553	582	612	655	699			
3 (42/55)													345	584	623	681	740	779	818	876	934	973	1071	
4 (48/60)																681	740	779	818	876	934	973	1071	1168

### NOTES

- Technical details: these details refer only for the coupling (GAS/CCE with backlash free red element 98 Shore-A), for torque limiters details see on page 26-27.
- Technical details: weights are relevant only to the pilot bore (GAS/CCE); inertias refer only for the coupling with maximum bore (GAS/CCE).

## ... + GSF (model with bellows coupling): technical data

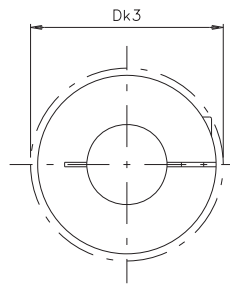
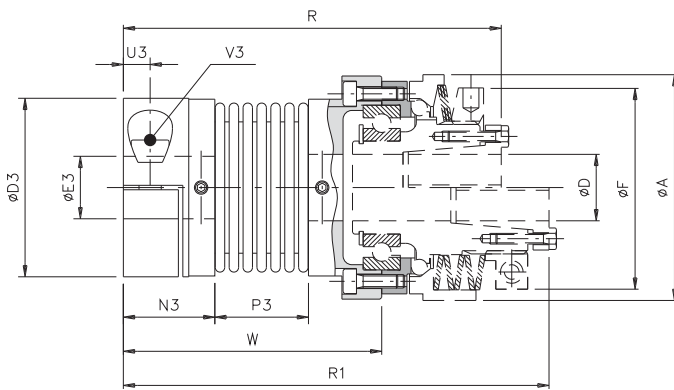

### DIMENSIONS

Size		D3	Dk3	E3 H7		N3	P3	U3	A	F	D max.	R	R1	W
SG	GSF			min.	max.									
00.40	1	34	36	5	16	17	16,5	4,5	44	38	12	72	84	48
00.47	2	40	44	8	20	20,5	21	5,5	50	42	17	87,5	102,5	58
0.63	3	55	58	10	30	22,5	27	6,5	70	62	20	109	125,5	68,5
1.80	4	65	73	14	38	26	32	8	85	75	25	126	144	81
2.96	5	83	89	14	45	31	41	9,5	100	82	35	156	174,5	102

### TECHNICAL DETAILS

Size		Torque [Nm]		Weight [kg]	Inertia [kgm <sup>2</sup> ]	Max. speed [Rpm]	grubscrews	screws V3	Tightening torque		Misalignments			Rigidity		
SG	GSF	Nom	Max						grubschr. [Nm]	screws [Nm]	angular α [°]	axial X [mm]	radial K [mm]	torsional R <sub>t</sub> [Nm/rad • 10 <sup>2</sup> ]	axial R <sub>a</sub> [N/mm]	radial R <sub>r</sub> [N/mm]
00.40	1	5	10	0,07	0,000024	4000	M3	M4	2,9	0,8	1° 30'	±0,5	0,20	3,050	30	92
00.47	2	15	30	0,14	0,000050	4000	M3	M5	6	0,8	1° 30'	±0,6	0,20	7,000	45	129
0.63	3	35	70	0,29	0,000229	4000	M4	M6	10	2	2°	±0,8	0,25	16,300	69	160
1.80	4	65	130	0,45	0,000622	3000	M4	M8	25	2	2°	±0,8	0,25	33,000	74	227
2.96	5	150	300	0,93	0,000834	2500	M4	M10	49	2	2°	±1,0	0,30	64,100	87	480

### TRANSMITTABLE TORQUE WITH CLAMP HUB ASSEMBLY

Size	Transmission torque [Nm] according to the Ø finished bore [mm]																							
	5	6	7	8	9	10	11	12	14	15	16	18	19	20	24	25	28	30	32	35	38	40	42	45
1	5	6	7	8	9	10	11	12	14	15	16													
2				13	14	16	18	19	22	24	25	29	30	32										
3							25	27	32	34	36	41	43	45	54	57	63	68						
4												75	79	83	100	104	116	124	133	145	158			
5														132	158	165	183	198	211	231	248	263	277	295

### NOTES

- ⊗ **Technical details:** these details refer only for the coupling (GSF), for torque limiters details, see on page 26-27
- ⊗ **Technical details:** weights are relevant only for the coupling with pilot bore (GSF); inertias refer only for the coupling with maximum bore (GSF).

# BACKLASH FREE TORQUE LIMITER "DSS/SG": additional information

## VERSIONS

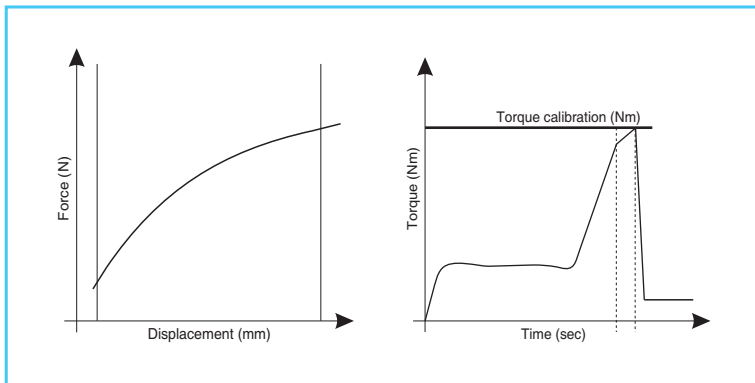

... / P

### Positive version (progressive spring)

This allows for a simpler and more linear calibration. Moreover, during disengagement it creates an increase in the torque, caused by the compression of springs, which, on presence of a non-homogenous (but normal) transmission, can be useful to avoid frequent disengagements and machine stops.

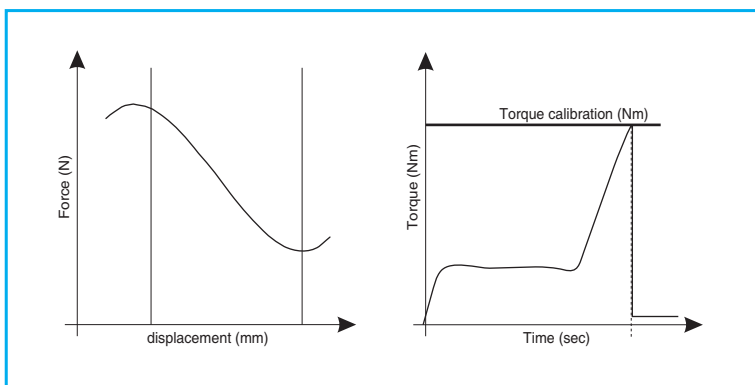

... / N

### Negative version (regressive spring)

It generates an immediate torque reduction, as soon as there is a minor overload, with consequent disengagement of the limiter and immediate stop of the drive. This characteristic is very useful on sensitive applications where even a slight increase of the loads can cause damage to the machine or to the machine product.

## TORQUE REGULATION

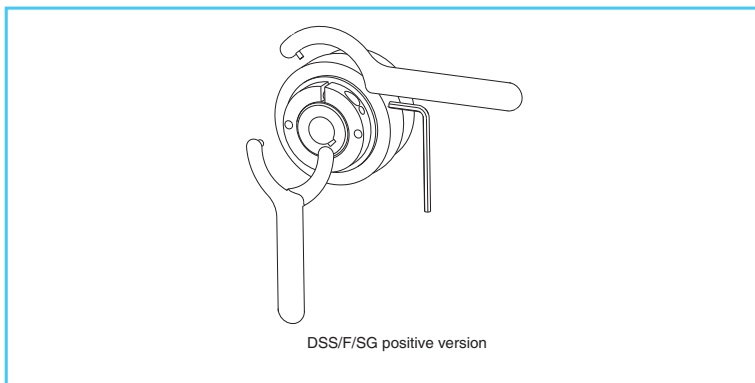

... / P

### Positive version (progressive spring)

As with the majority of ComInTec TORQUE LIMITERS, by turning the adjuster nut clockwise the disengagement torque increases. On the contrary turning it counter-clockwise, you obtain a reduction of the torque.

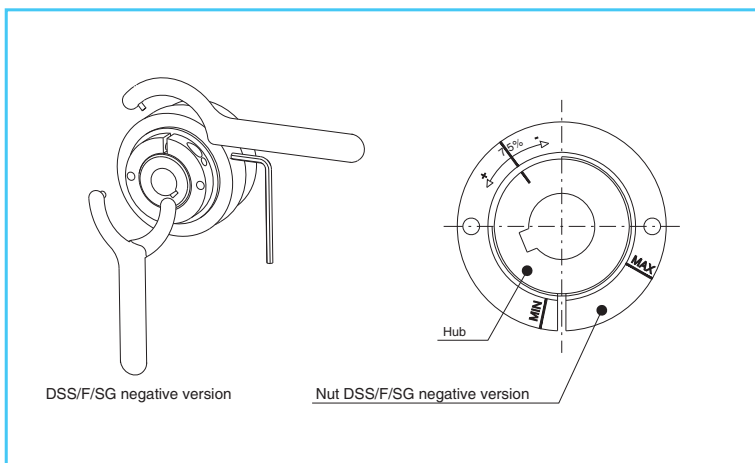

... / N

### Negative version (regressive spring)

Adjustment of the Negative version is opposite to all other units in our range. Unlike the traditional units, by rotating the adjuster nut clockwise the disengagement torque will reduce, and therefore to increase the torque the nut must be rotated anti-clockwise. To assist the operator in setting, there are clear markings on the nut showing 75% of the max torque and +/- Min/Max directions indicated.

**Unless otherwise requested, these models are supplied pre-calibrated at 75% of the maximum torque value of the spring's chosen configuration.**

# BACKLASH FREE TORQUE LIMITER "DSS/SG": additional information

## OTHER COUPLING TYPES AVAILABLE

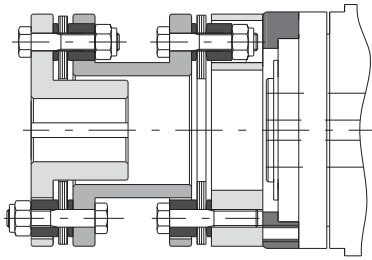

DSS/SG model with double flexing torsionally rigid metal disc coupling **GTR/D** when torsional rigidity is required and ability to accommodate radial misalignment.

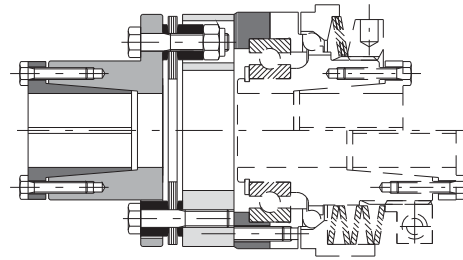

DSS/SG model with single flexing disc coupling **GTR/S** for applications where torsional rigidity is required.

## TORQUE TRANSMISSION

Torque transmission [Nm] relevant to the springs configuration									
Size	Positive version (P)					Negative version (N)			
	A5S1P )())	A10S2P ))(()())	A7S1P )()()	A5M1P )()	A5G1P )()	A1N )	A2N )	A3N ))	A4N )))
00.40		3 - 6,5	1,5 - 3,5			0,7 - 1,5	1 - 3	2 - 5	
00.47			5 - 12	9 - 20		2 - 5	3 - 12	7 - 15	
0.63	5 - 20			11 - 40	20 - 75	5 - 14	12 - 28	24 - 50	
1.80	12 - 35				30 - 105	9 - 28	18 - 60	40 - 100	
2.96			17 - 54	35 - 115	50 - 200	20 - 45	42 - 95		85 - 200
3.116	40 - 110			70 - 290	110 - 415	35 - 100	75 - 200		195 - 415
4.138	75 - 275			140 - 395	315 - 750	75 - 190	140 - 345		245 - 720

## ORDER EXAMPLE

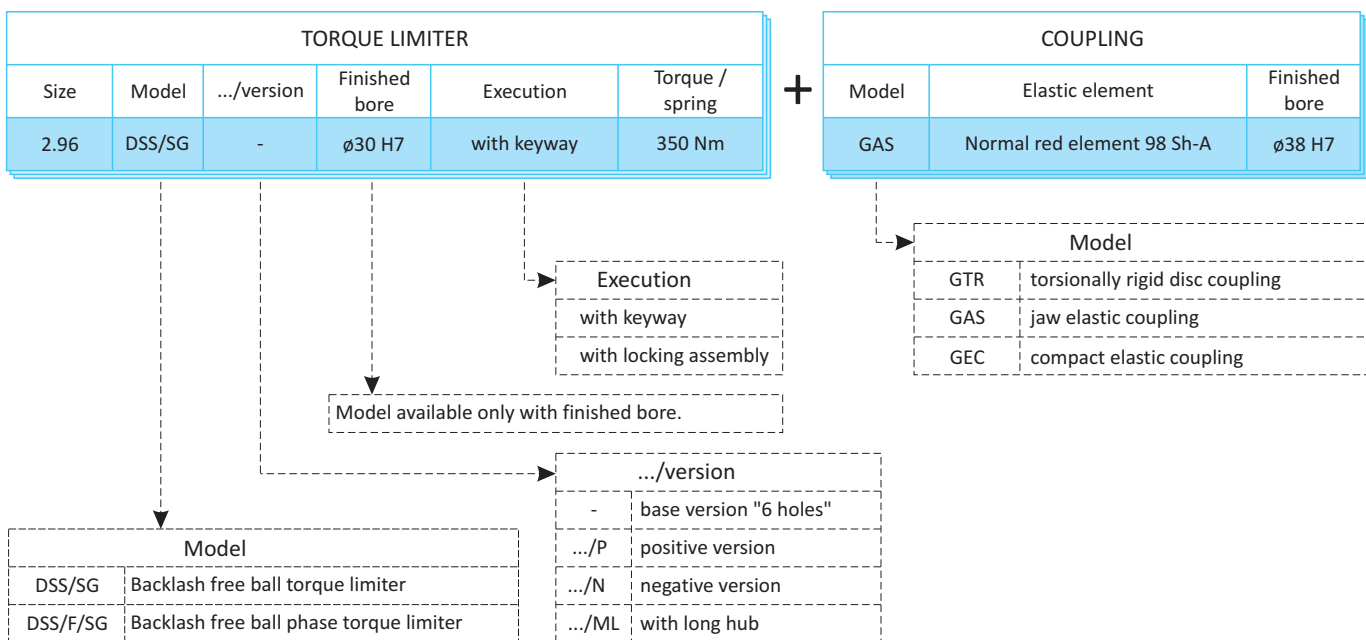

# Axial force limiter "DSA": introduction and technical data



- ⊙ Axial backlash free.
- ⊙ The same calibrating force both in tension and in compression.
- ⊙ Automatic re-engagement in the correct position after release.
- ⊙ Innovative calibrating force system by quote "H".
- ⊙ Manufactured in steel, fully machined.
- ⊙ Maintenance free for a high reliability.
- ⊙ Mechanical stop to avoid the traction rod withdrawing after the release.
- ⊙ Force range: 30 N - 7000 N.

### ON REQUEST

- ⊙ Complete with traction-compression rods and rod ends.
- ⊙ Sensor or microswitch in axial or radial position.
- ⊙ Possibility of special versions for specific applications.

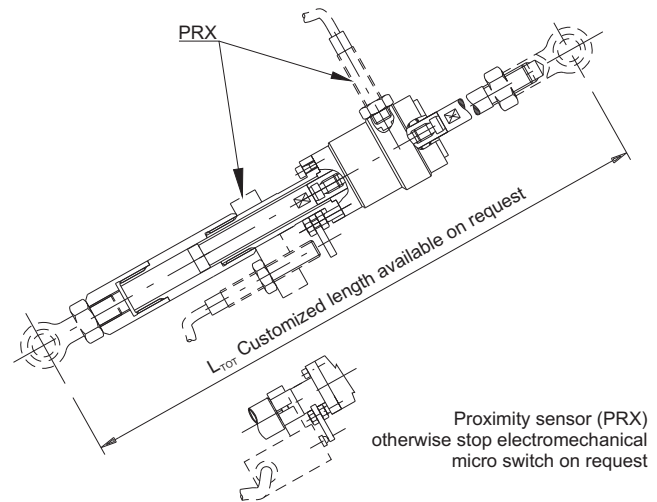
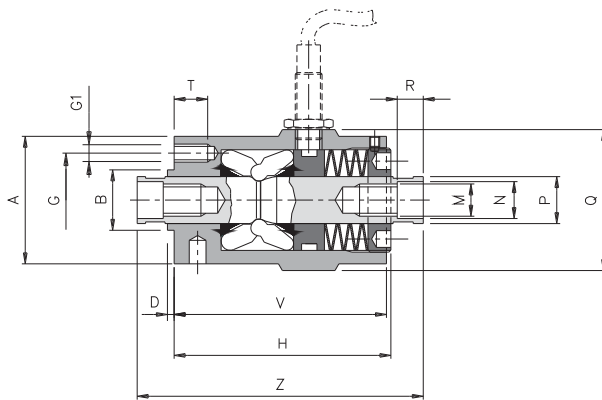

## DIMENSIONS AND TECHNICAL DETAILS

Size	Force [N]					A	B h7	D	G	G1	M	N H7	P	Q	R	T	V	Z	Weight [Kg]
	ST	SQ	A6S1	A6G1	A7G1														
1	30 - 120	40 - 480		310 - 1400		30,5	14	2	22	6xM3	M6x0,75	7	10	36,5	5	7	50	66	0,3
2			350 - 1250		350 - 3200	38	18	2	28	6xM5	M10x0,75	11	14	42	9	10	61	85	0,5
3			800 - 3200	1200 - 7000		50	25	3	37	6xM6	M12x1	13	20	56	10	11	78	105	1,1

## APPLICATION FIELD

- ⊙ Hollow shaft gearboxes.
- ⊙ Movement cams and eccentrics.
- ⊙ Articulated movements for booster and motor slides.

## ADVANTAGES AND BENEFITS

- ⊙ Protect shaft hung gearboxes against overload within the transmission.
- ⊙ Protect motor slides or other elements against collision or impact of mechanical stops.
- ⊙ Protect generic movements against impacts or bad positioning.

## ASSEMBLY EXAMPLES

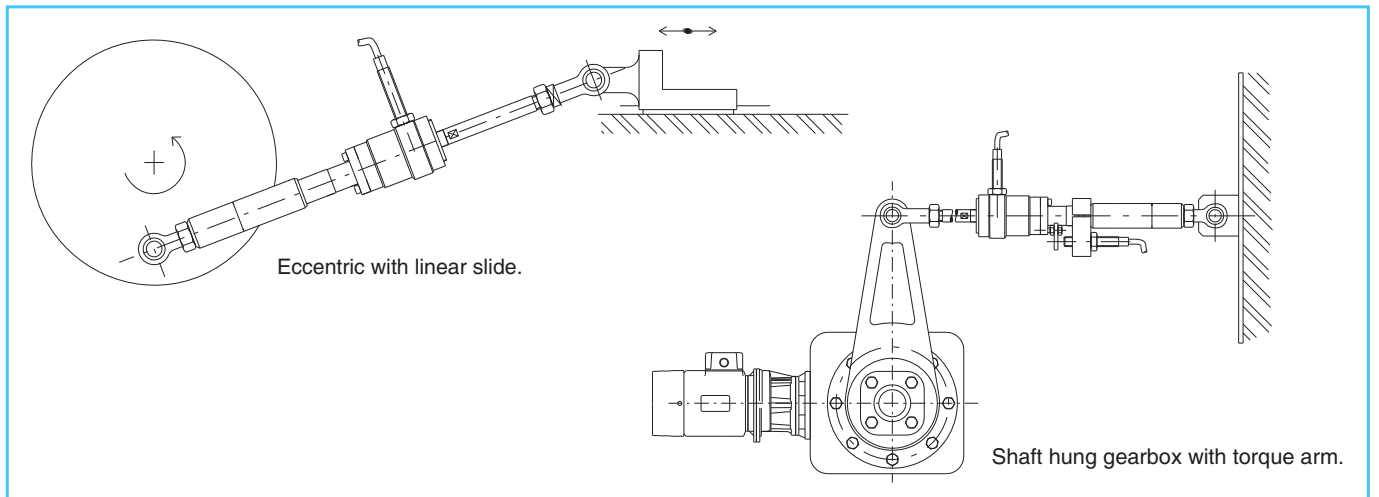









- ⊙ Simple and precise calibration.
- ⊙ Transmission engagement / disengagement and torque limiter functions.
- ⊙ Reliability and repetitiveness of the calibration torque.
- ⊙ Torque variation whilst in motion, by pressure regulation.
- ⊙ Free rotation after the disengagement through a complete disconnection between the parts.
- ⊙ Low residual torque on disconnected parts.
- ⊙ Models available only with finished bore.

**ON REQUEST**

- ⊙ Complete with transmission element machined and assembled (plate wheel, pulley, gear, ...).
- ⊙ Can be supplied with various types of rigid/elastic couplings for in-line shafts transmission.
- ⊙ Possibility of shaft connection with finished bore, locking assembly or other systems.
- ⊙ Available in anti-corrosive version, with specific surface treatments.

	DSR/F/AP: Complete engagement-disengagement of the transmission, also for long periods	from 7 to 30000 Nm max bore $\varnothing$ 120 mm	Page 34
	DSR/F/AP + GEC: compact coaxial connection for simple maintenance without being forced to remove the coupling	from 7 to 30000 Nm max bore $\varnothing$ 180 mm	Page 35
	DSF/TF/AP: friction motion transmission as tensioner	from 3 to 875 Nm max bore $\varnothing$ 65 mm	Page 36
	DSF/TF/AP/TAC: simple and economic coaxial shaft connection.	from 3 to 875 Nm max bore $\varnothing$ 80 mm	Page 37

**APPLICATION FIELD**

- ⊙ Machines with work cycles of variable torque.
- ⊙ Test benches.
- ⊙ Coiler and uncoilers.
- ⊙ Transmission systems with varied products.
- ⊙ Cut format systems.

**ADVANTAGES AND BENEFITS**

- ⊙ Engage/disengage different product transmission lines.
- ⊙ Maintain tension of wire/film coils.
- ⊙ Regulate different torques depending on the change of the format.
- ⊙ Protect the motor gearbox against every form of overload.
- ⊙ When it's necessary for complete disengagement of the transmission.

**ASSEMBLY EXAMPLES**

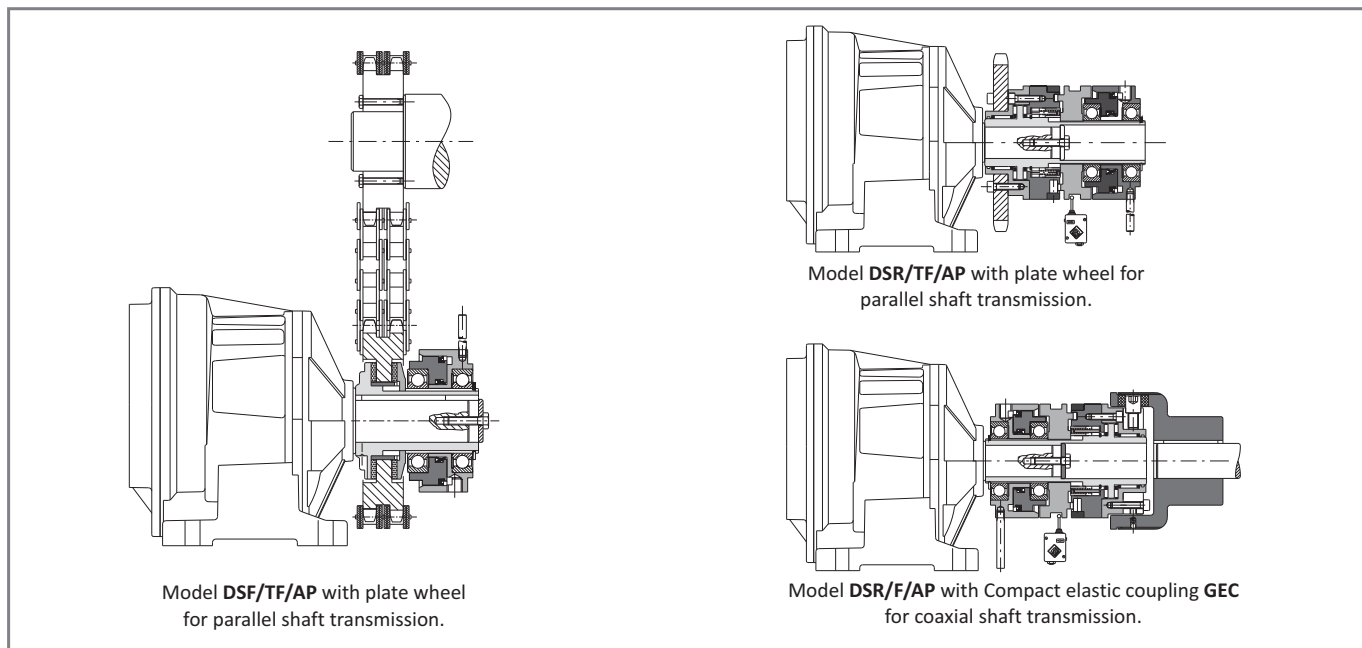

Model DSF/TF/AP with plate wheel for parallel shaft transmission.

Model DSR/TF/AP with plate wheel for parallel shaft transmission.

Model DSR/F/AP with Compact elastic coupling GEC for coaxial shaft transmission.

**NOTE**

⊗ Avoid rigid locking of the anti-rotating pin of the cylinder as it can cause imbalances during rotation

# DSR/F/AP (roller phase pneumatic clutch): technical data



- ⊙ Transmission through rollers with re-engagement in phase 360° (equidistant on request, 30°, 45°, ...).
- ⊙ Free rotation for long periods after overload: ... / CS.
- ⊙ Suitable for high rotation speeds.
- ⊙ Maintenance free for high reliability.
- ⊙ Arranged to add a microswitch / proximity to stop the motor drive.
- ⊙ Torque range: 5 – 30000 Nm; max. bore  $\phi$ 120 mm.

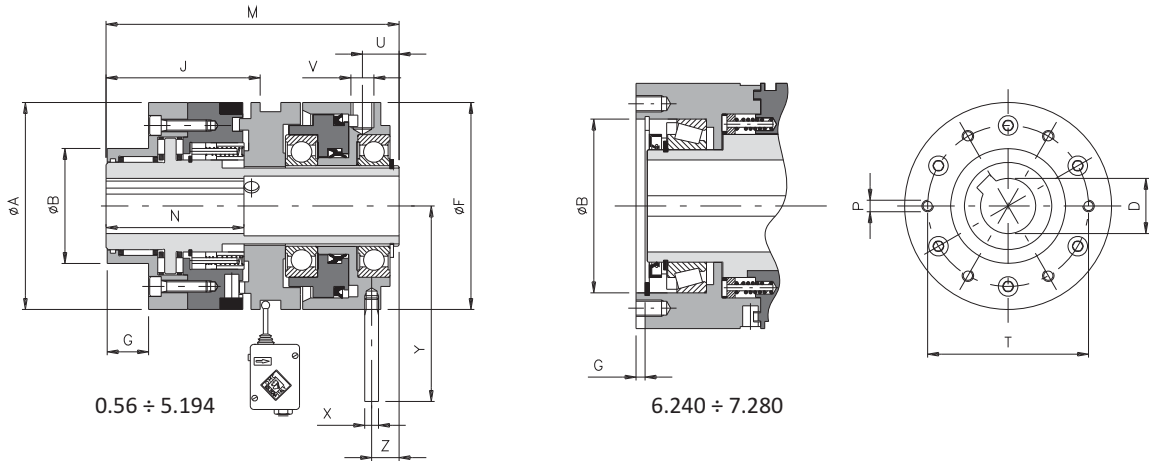

## DIMENSIONS AND TECHNICAL DETAILS

Size	Torque [Nm] 1 - 6 - 15 bar	A	Standard flange				D H7 max.	F	J	M	N	U	V	Z	X	Y	Max. speed [Rpm]	Weight [Kg]
			B h7	G	P	T												
0.56	7 - 29 - 70	56	38	10	M5	48	18	56	56	97	45	11,5	1/8"	7,5	6	58	11000	1,5
1.90	15 - 115 - 280	90	50	18	M5	70	25	90	67,5	128	60	15	1/4"	11	6	80	7000	5,0
2.110	20 - 195 - 480	110	60	20	M6	89	38	110	85	148	70	17,5	1/4"	13,5	8	105	5000	9,0
3.130	25 - 310 - 780	130	80	19	M8	105	45	130	90,5	160	100	18,5	1/4"	14,5	8	115	4300	13,3
4.160	55 - 530 - 1335	160	100	22	M10	125	55	160	109	192	115	25	1/4"	17	10	146	3600	19,0
5.194	330 - 1600 - 3970	194	120	26	M12	155	65	215	125	202	145	26,5	1/4"	18	12	184	3200	35,8
6.240 CB	1100 - 5800	240	*		M16	200	90	290	*	305	* On request							
6.240 CA	3400 - 15000	240			M16	200	90	290		355								
7.280 CB	1500 - 7500	280			M20	230	120	345		320								
7.280 CA	7000 - 30000	280			M20	230	120	345		375								

## TORQUE TRANSMISSION

Size	Torque transmission [Nm] according to the pressure [bar]							
	1	2	3	4	5	6	10	15
0.56	7	11	16	20	24	29	45	70
1.90	15	35	55	75	95	115	185	280
2.110	20	50	85	125	160	195	330	480
3.130	25	80	135	195	250	310	520	780
4.160	55	150	245	340	435	530	900	1335
5.194	330	550	830	1085	1340	1600	2600	3970
6.240 CB	1100	2000	3000	3900	4800	5800	-	-
6.240 CA	3400	6200	9040	11760	15000	-	-	-
7.280 CB	1500	2500	3700	5000	6200	7500	-	-
7.280 CA	5000	10000	15000	20000	25000	30000	-	-

## NOTES

⊗ Technical details: weights are relevant to the torque limiter with pilot bore (DSR/F/AP).

## ... + GEC (model with compact elastic coupling): technical data

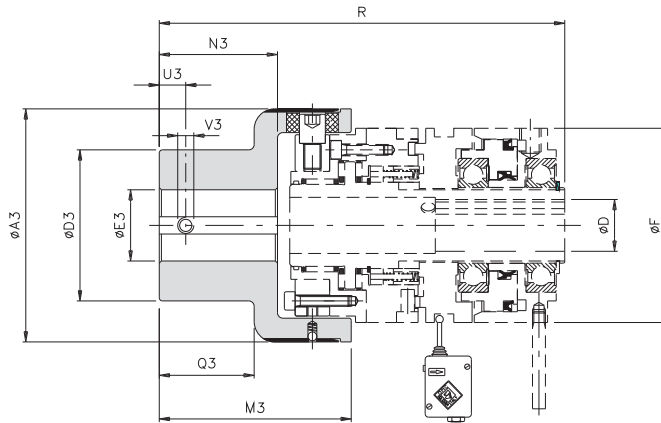

### DIMENSIONS

Size		Torque [Nm]		A3	D3	E3 H7		M3	N3	Q3	D H7 max.	F	R
DSR/F/AP	GEC	Nom.	Max.			pilot bore	max.						
0.56	0	70	110	78	50	10	28	63,5	32	28	18	56	142
1.90	1	280	420	108	70	12	38	89	49	44	25	90	189
2.110	2	570	860	130	80	15	45	111	65	59	38	110	229
3.130	3	980	1500	161	100	15	60	140	85	77	45	130	268
4.160	4	2340	3600	206	120	20	70	168	105	97	55	160	323
5.194	5	3880	5800	239	135	30	80	201	130	120	65	215	360
6.240 CB	6	15000	20000	On request									
6.240 CA													
7.280 CB	7	30000	35000										
7.280 CA													

### TECHNICAL DETAILS

Size		Misalignments							Max. speed [Rpm]	Weight [Kg]
DSR/F/AP	GEC	Angular $\alpha$ [°]		Axial [mm]		Radial [mm]		Torsional $\alpha$ [°]		
		continuous	intermittent	continuous	intermittent	continuous	intermittent			
0.56	0	1°	1° 30'	± 0,7	± 1,5	0,5	0,7	2°	5500	1,1
1.90	1	0° 48'	1°	± 0,7	± 1,5	0,5	0,7	2°	5000	3,3
2.110	2	0° 36'	0° 48'	± 0,7	± 1,5	0,6	0,7	1° 45'	4500	5,9
3.130	3	0° 30'	0° 42'	± 0,8	± 1,6	0,6	0,8	1° 15'	4000	10,9
4.160	4	0° 24'	0° 30'	± 0,8	± 1,6	0,6	0,8	1°	3100	19,8
5.194	5	0° 24'	0° 30'	± 0,8	± 1,6	0,6	0,8	1°	2800	30,5
6.240	6	0° 24'	0° 30'	± 0,8	± 1,6	0,6	0,8	1°	-	-
7.280	7	0° 24'	0° 30'	± 0,8	± 1,6	0,6	0,8	1°	-	-

### OTHER COUPLING MODELS

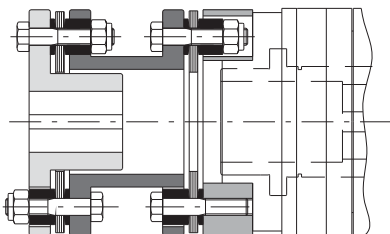

Model DSR/F/AP with double flexing torsionally rigid metal disc coupling GTR-D, when torsional rigidity is required and ability to accommodate radial misalignment.

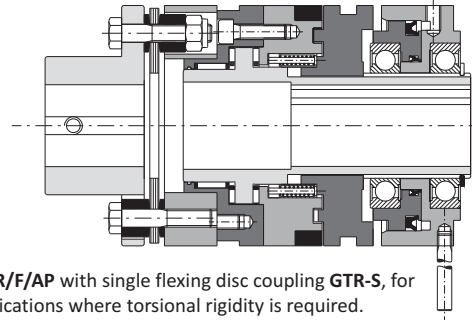

Model DSR/F/AP with single flexing disc coupling GTR-S, for applications where torsional rigidity is required.

### NOTES

- ⊗ **Technical details:** these details refer only for the coupling (GEC); for torque limiters details see on page 34.
- ⊗ **Technical details:** weights are relevant only for the coupling with pilot bore (GEC).

## DSF/TF/AP (friction pneumatic clutch): technical data



- ⊙ Friction torque transmission.
- ⊙ As tensioner, brake and torque limiter.
- ⊙ Constant adjustment of the calibration torque.
- ⊙ Available with special friction rings for specific requirements.
- ⊙ Available in version .../SI to stop the transmission after an overload.
- ⊙ Torque range: 3 – 875 Nm; max. bore  $\varnothing$  65 mm.

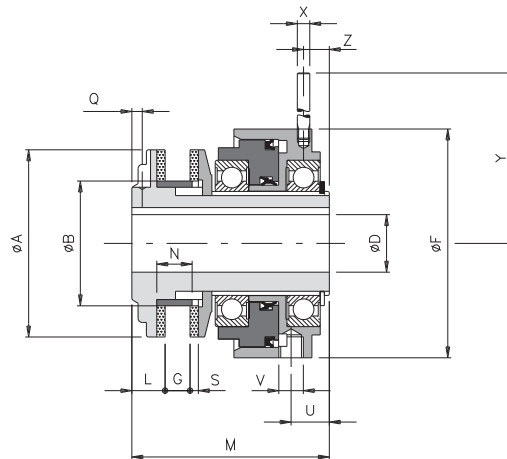

### DIMENSIONS AND TECHNICAL DETAILS

Size	Torque [Nm] 1 - 6 - 10 bar	A	B H7	D H7 max	F	G		L	M	N	On request	S	U	V	Z	X	Y	Max. speed [Rpm]	Weight [Kg]
						Q													
0.50	3 - 13 - 20	50	36	19	56	3,5	6	11	62	10	3,5 - M4	3	11	1/8"	7	6	58	7600	0,7
1.70	6 - 43 - 70	70	45	25	90	5	10	15	85	15	4,5 - M4	4	14,5	1/4"	10,5	6	80	5450	2,4
2.90	15 - 88 - 135	90	60	38	110	7	12	16	95	17	5 - M6	4	17,5	1/4"	13,5	8	105	4250	4,3
3.115	25 - 153 - 220	115	72	45	130	9	16	18	112	21	5 - M6	4	18,5	1/4"	14,5	8	115	3350	7,0
4.140	70 - 230 - 330	140	85	55	160	11	19	20	128	25	6 - M6	5	24,5	1/4"	16,5	10	146	2750	11,9
5.170	170 - 700 - 875	170	98	65	215	15	22	22,5	140	28	6,5 - M8	5	26,5	1/4"	18	12	184	2250	19,8

### TORQUE TRANSMISSION

Size	Torque transmission [Nm] in according to pressure [bar]						
	1	2	3	4	5	6	10
0.50	3	5	7	9	11	13	20
1.70	6	10	19	28	36	43	70
2.90	15	27	42	57	73	88	135
3.115	25	52	79	105	130	153	220
4.140	70	115	145	175	205	230	330
5.170	170	280	390	500	600	700	875

### NOTE

⊗ Technical details: weights are relevant to the torque limiter with pilot bore (DSF/TF/AP).

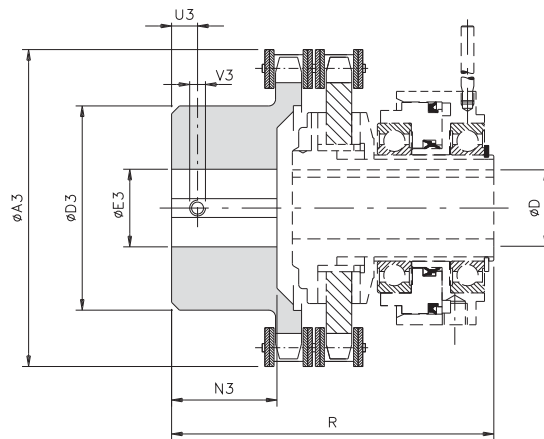

**DIMENSIONS AND TECHNICAL DETAILS**

Size	Torque [Nm] 1 - 6 - 10 bar	A3	D3	E3 H7		N3	D H7 max.	F	R	U3	V3	Max. speed [Rpm]	Weight [Kg]
				pilot bore	max.								
0.50	3 - 13 - 20	75	50	12	28	19	19	56	84	8	M4	7600	0,6
1.70	6 - 43 - 70	101	70	16	38	29	25	90	117	8	M4	5450	1,7
2.90	15 - 88 - 135	126	89	20	55	38	38	110	138	12	M6	4250	4,1
3.115	25 - 153 - 220	159	112	20	70	56,5	45	130	174	12	M6	3350	7,1
4.140	70 - 230 - 330	184	130	28	80	59,5	55	160	194	15	M8	2750	14,1
5.170	170 - 700 - 875	216	130	30	80	88	65	215	233	15	M8	2250	19,2

**OTHER COUPLING MODELS**

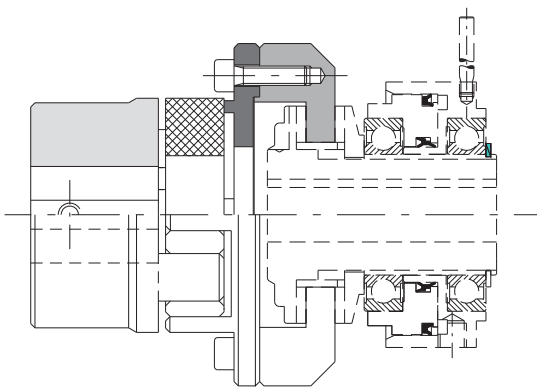

Model **DSF/TF/AP** with elastic jaw coupling **GAS** to accommodate high misalignments.

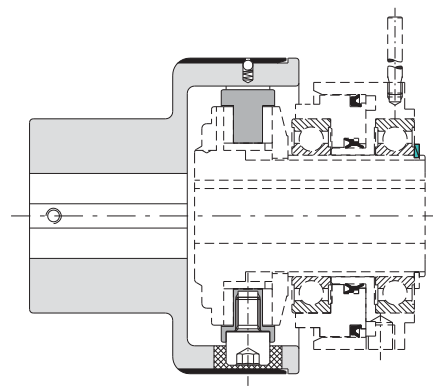

Model **DSF/TF/AP** with compact elastic coupling **GEC** for simple maintenance without removing the coupling.

**NOTES**

- ⊗ **Technical details:** data is relevant to the whole assembly (DSF/TF/AP/TAC).
- ⊗ **Technical details:** weights are relevant to the whole assembly with pilot bore (DSF/TF/AP/TAC).

# PNEUMATIC CLUTCH ".../AP": additional information

## MODELS ON REQUEST:

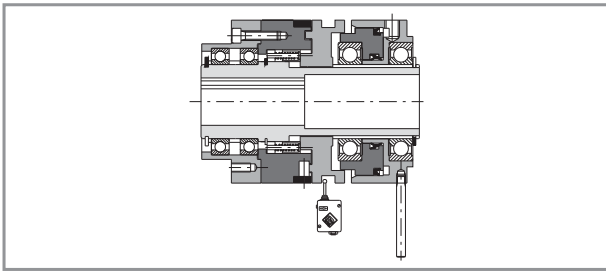

### DSR/F/AP/CS

Version with ball bearings as an alternative to the rollers. Suitable for long rotation on disengagement.

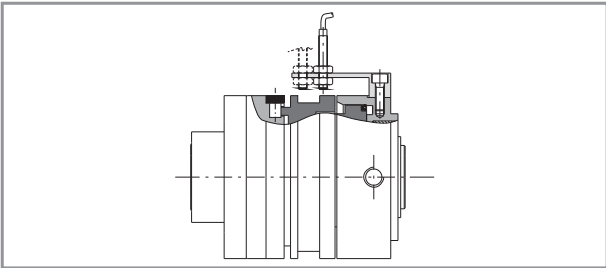

### .../PRX

Version with proximity inductive sensor PRX M8x1, integrated into the DSR/F/AP. Compact and versatile solution, without adding equipment and/or external components.

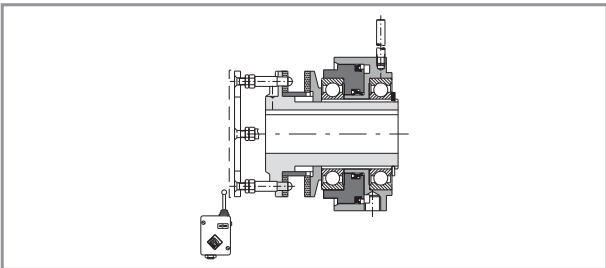

### DSF/TF/AP/SI

Friction clutch with intervention signal and further automatic re-engagement. This characteristic requires particular machining on the drive element, which has to be supplied together with the torque limiter.

## ORDER EXAMPLE

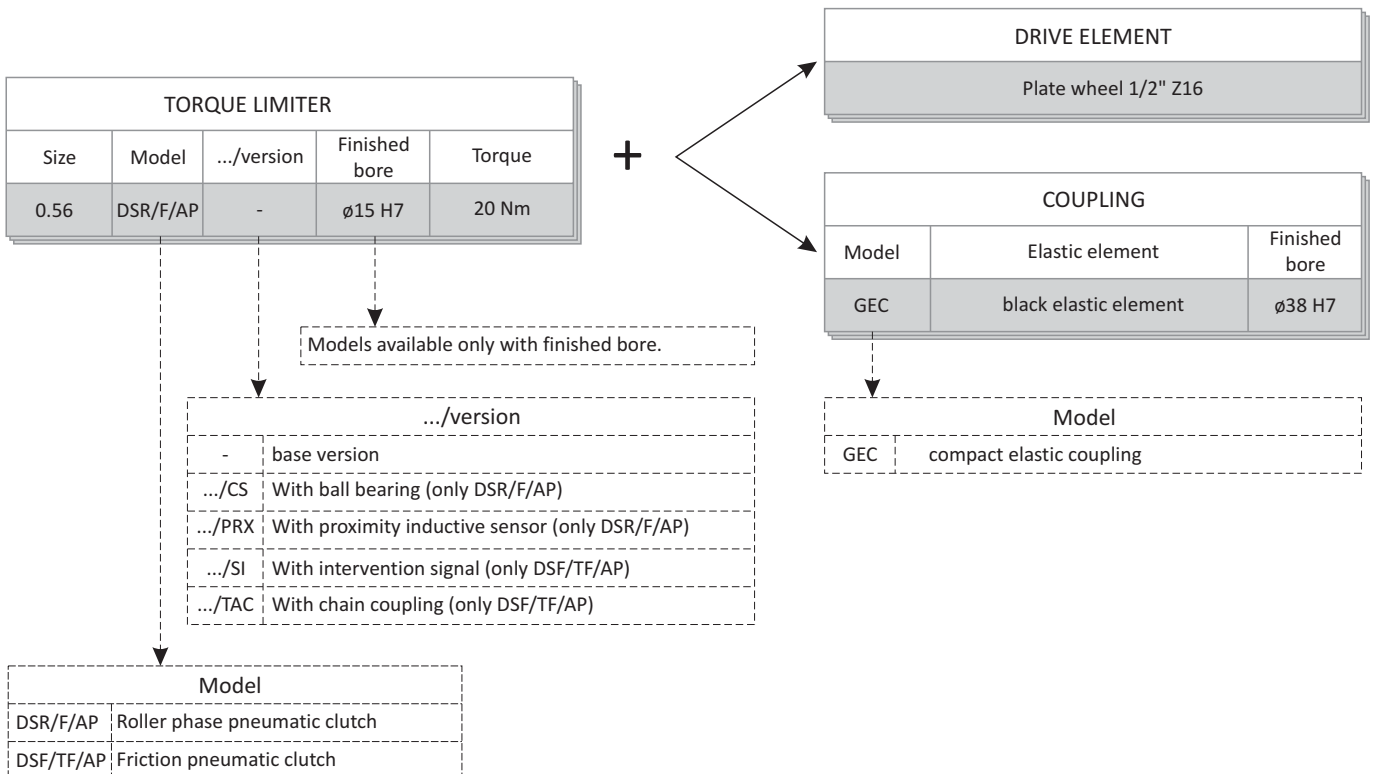

## ELECTROMECHANICAL SWITCH "EM1"

- Protection level IP57 DIN 40050.
- Adjustment of the lever end position possible.
- Die-cast aluminium box.
- Operation temperature range from  $-10^{\circ}\text{C}$  to  $+85^{\circ}\text{C}$ .
- Three different options of voltage input with 1 or 2 contacts available.
- Initial stroke 0,5 mm, Extra stroke:  $4 \div 8$  mm depending on setting (possible in a range of 6 mm).



Switch with one contact (EM1).

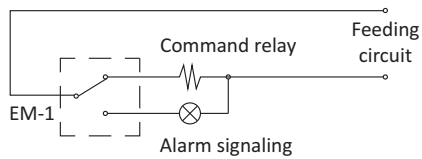

Switch with two contacts (EM2).

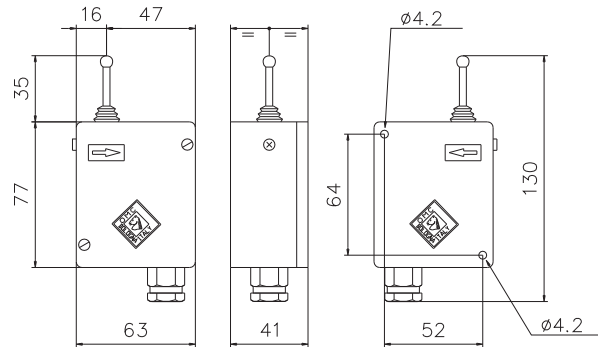
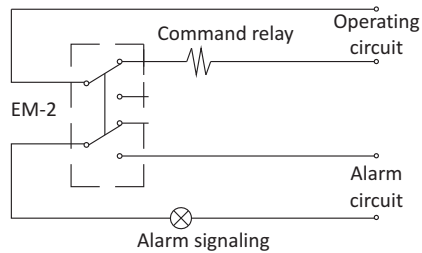

Other switches available on request.

## PROXIMITY SENSOR "PRX"

- Standard version: Brass cover with protection level IP67 DIN 40050.
- Electric contact:  $5 \div 24$  VdC.
- Frequency: 2000 Hz.
- Output: NPN (N.O.-N.C.) – PNP (N.O.-N.C.).
- Operating distance: max 1 mm.
- Cable length: 2 m (3x0,2).

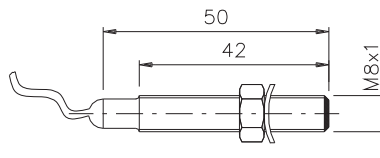

Other sensors available on request.

# CALIBRATION SYSTEM WITH "H" DIMENSION

The transmitted force of a torque limiter can be determined with one or more axial springs and different forces, depending on how they are combined. Efficient controls on all components make it possible to realize tables for simple, easy and most of all, quick torque limiter calibration, without any need of special equipment.

Search in the technical catalogues, in the table "torque calibration" the value that is closest to the required torque of the selected torque limiter size and spring combination. Find the related value of "dimension H". Alter the spring pressure by adjusting the ring nut until you reach "dimension H", the distance between nut ring and flange (see drawings). Finally, fix the nut ring by its locking mechanism.

With this calibration system you obtain:

- Torque calibration without removing the torque limiter.
- Quick torque calibration.
- Avoid calculating and reading errors due to misinterpretation of drawings.
- Simple variation or reset of the torque.

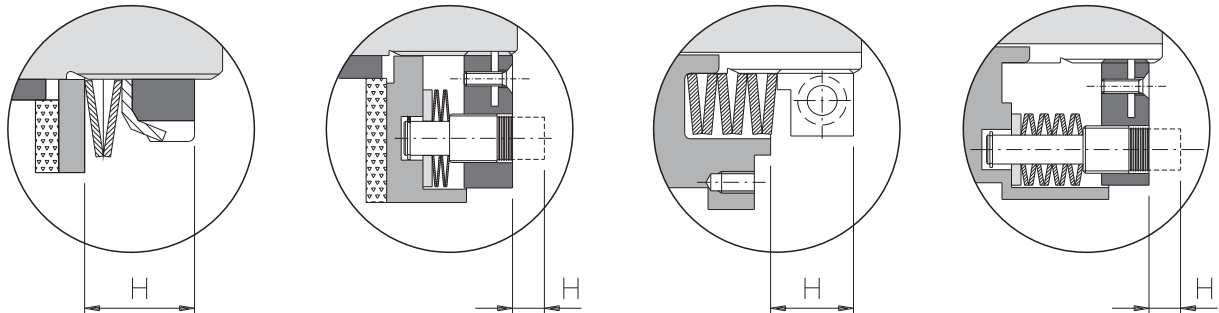

## SPRING COMBINATION EXAMPLES

	<b>A1S1</b> <b>A1M1</b> <b>A1G1</b> <b>A1N</b>	One axial thin spring, arranged simply One axial average spring, arranged simply One axial large spring, arranged simply One axial "negative"spring, arranged simply		<b>A3S1</b> <b>A3M1</b> <b>A3G1</b>	Three axial thin springs, arranged simply Three axial average springs, arranged simply Three axial large springs, arranged simply
	<b>A2S2</b> <b>A2M2</b> <b>A2G2</b> <b>A2N</b>	Two axial thin springs, arranged double Two axial average springs, arranged double Two axial large springs, arranged double Two axial "negative"springs, arranged double		<b>A4S1</b> <b>A4M1</b> <b>A4G1</b>	Four axial thin springs, arranged simply Four axial average springs, arranged simply Four axial large springs, arranged simply
	<b>A3S3</b> <b>A3G3</b> <b>A3N</b>	Three axial thin springs, arranged triple Three axial average springs, arranged triple Three axial "negative" springs, arranged triple		<b>A5S1P</b> <b>A5M1 - A5M1P</b> <b>A5G1 - A5G1P</b>	Five axial thin springs, arranged simply Five axial average springs, arranged simply Five axial large springs, arranged simply
	<b>A4G2</b>	Four axial large springs, arranged double		<b>A6S1</b> <b>A6M1</b> <b>A6G1</b>	Six axial thin springs, arranged simply Six axial average springs, arranged simply Six axial large springs, arranged simply
	<b>A6M2</b> <b>A6G2</b>	Six axial average springs arranged double Six axial large springs arranged double		<b>A7S1P</b> <b>A7G1 - A7G1P</b>	Seven axial thin springs, arranged simply Seven axial large springs, arranged simply

## EXAMPLES OF DETERMINING, REGULATING AND CALIBRATING A TORQUE LIMITER

Electric motor: power = 7,5 kW  
Rpm = 1450  
f (safety factor) = 1,5

Use the following formula to get an idea of the intervention torque:

$$C = \frac{\text{kW} \cdot f \cdot 9550}{\text{Rpm}} = \frac{7,5 \cdot 1,5 \cdot 9550}{1450} = 74 \text{ Nm}$$

Find in the technical catalogue (in this case DF) the required spring combination and the relative dimension H for the selected torque limiter (in this case DSF 1.70), to have the desired torque (in this case springset A1M1 – dimension H 12,2 mm – torque 74Nm).

Please note: Due to the expansion coefficient and the load loss of all springs in general, the "dimension H" can vary slightly.

➔ You can find all the calibration torque values by typing in "dimension H" on our website "www.comintec.it".

Torque range  
Spring configuration  
Torque limiter size

Size 2.90 (6 ÷ 450) Nm					
H (mm)	A1S1 ) Cod."I"	A1M1 ) Cod."J"	A1G1 ) Cod."H"	A2G2 ) Cod."S"	A3G3 ) Cod."X"
10,6	38				
11	31	105			
11,4	25	99	140		
11,8	12	89	124		
12,2		74	101		
12,6		49	74		
13		13	40		
13,4				280	
13,8				256	
14,2				213	
14,6				158	
15				90	
15,4					450
15,8					415
16,2					353
16,6					276
17					185

Measure dimension "H"  
Torque calibration



## LABEL

The Company ComInTec uses a plastic label with indelibly printed information necessary to identify all product groups and production history. This information is also useful to order spare parts, repeat orders and to get product information.  
Explanation of the data:

Example:

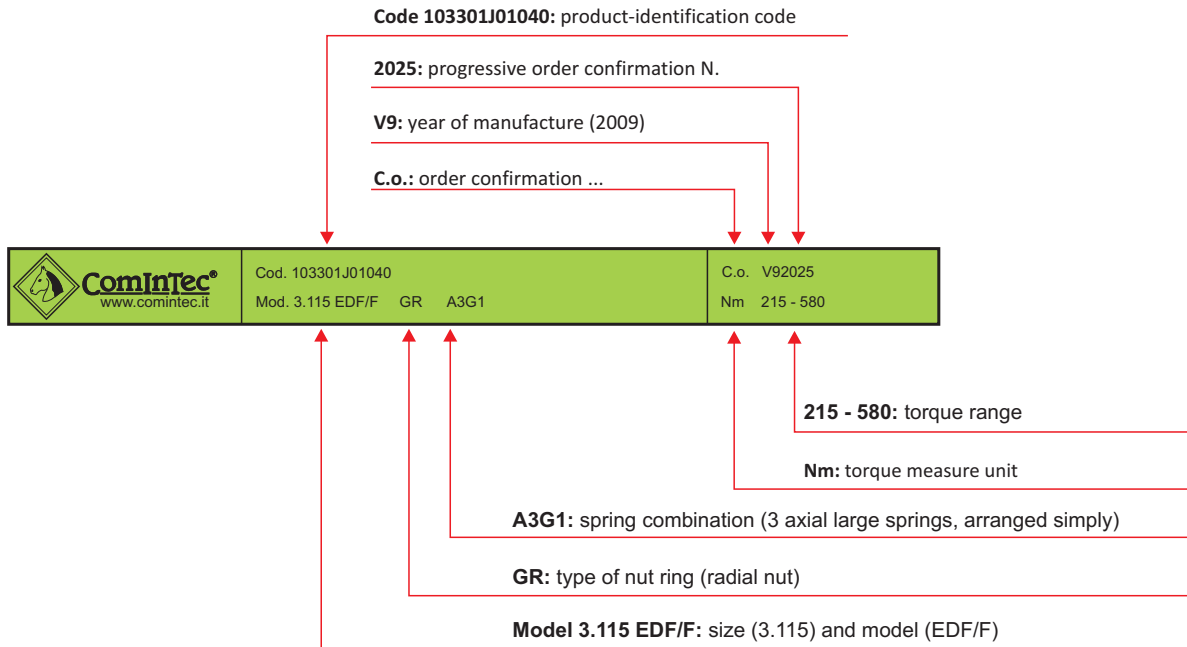

## BORES AND KEYWAYS (ACCORDING TO UNI 6604)

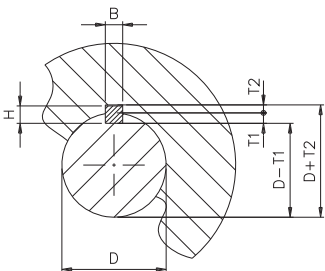

D	>10 12	>12 17	>17 22	>22 30	>30 38	>38 44	>44 50	>50 58	>58 65	>65 75	>75 85	>85 95	>95 110	>110 130	>130 150	>150 170	>170 200
<b>B H9</b>	4	5	6	8	10	12	14	16	18	20	22	25	28	32	36	40	45
<b>H</b>	4	5	6	7	8	8	9	10	11	12	14	14	16	18	20	22	25
<b>T1</b>	2,5	3	3,5	4	5	5	5,5	6	7	7,5	9	9	10	11	12	13	15
<b>T2</b>	1,8	2,3	2,8	3,3	3,3	3,3	3,8	4,3	4,4	4,9	5,4	5,4	6,4	7,4	8,4	9,4	10,4
	+0,1 0		+0,2 0										+0,3 0				

## ComInTec® CERTIFICATIONS



- UNI EN ISO 9001:2008 certified company since February 1996



- Continuous product-research and development, some of them with Italian and European **PATENT**.



- Company and production "Made in Italy".



- Internal and external environment protection complying with directive **2002/95/CE (RoHS)**, that forbids the use of harmful substances during the production process or in the end product, and complying with D.Lgs. 626/94 for security and health at work.



- ABS** Certification for the use in the Naval industry.



- European Power Transmission Distributors Association (EPTDA). The largest organisation of distributors and manufacturers of power transmission and motion control products in Europe.

## ASK FOR A PROJECT

### **Your needs are our priorities.**

If you need help for a product design, contact ComInTec experts for assistance and advice. It helps to fill in this form. Your request will be handled in the shortest time possible.

#### **General information:**

- ⊙ *Company name:* -----
- ⊙ *City / State:* -----
- ⊙ *Name / Surname:* -----
- ⊙ *Title:* -----
- ⊙ *Phone:* -----
- ⊙ *E-mail / website:* -----
- ⊙ *Quantity:* -----
- ⊙ *Planned yearly quantities:* -----
- ⊙ *Target price:* -----

#### **Use:**

- ⊙ *OEM name / website:* \_\_\_\_\_
- ⊙ *Application field / type of machine:* \_\_\_\_\_
- ⊙ *Where it's applied and what it protects:* \_\_\_\_\_
- ⊙ *Model currently used:* \_\_\_\_\_
- ⊙ *Nominal torque (Nm):* \_\_\_\_\_
- ⊙ *Speed (Rpm):* \_\_\_\_\_
- ⊙ *Workplace:*
  - Clean*
  - Dusty*
  - Oily*
  - Humid / Wet*
  - Other* \_\_\_\_\_

- ⊙ Re-engagement position:
  - Equidistant
  - 360°
  - Not important
  - Other \_\_\_\_\_

- ⊙ Electric signal of overload required:
  - Yes
  - No

**Transmission:**

- Parallel
- In line

- ⊙ Driving shaft diameter (mm): \_\_\_\_\_

- ⊙ Driving shaft connection type:
  - Keyway
  - Locking assembly
  - Other \_\_\_\_\_

- ⊙ Type of drive component e.g sprocket, gear etc. (parallel transmission): \_\_\_\_\_

- ⊙ Type of coupling (in line transmission): \_\_\_\_\_

- ⊙ Driven shaft diameter (mm): \_\_\_\_\_

- ⊙ Driven shaft connection type:
  - Keyway
  - Locking assembly
  - Other \_\_\_\_\_

- ⊙ Notes: \_\_\_\_\_  
 \_\_\_\_\_  
 \_\_\_\_\_

Signature  
 -----

 **PLEASE ALSO SEND, IF AVAILABLE, A DRAWING OR PHOTOGRAPH. IT CAN ASSIST US ENORMOUSLY IN HELPING US TO FULLY UNDERSTAND YOUR APPLICATION.**

Send to tecnico@comintec.it or by fax +39 051 782256 (Att. Technical Department)

## PRODUCTION PROGRAMME

