



# Fenner Drives Trantorque® Keyless Bushings: Power and Precision

Fenner Drives, a worldwide leader in mechanical power transmission and motion control solutions, is pleased to present our comprehensive line of Trantorque Keyless Bushings.

Backed by the world's largest inventory of product ready for same-day shipment, the best customer service support in the industry, and the engineering expertise and manufacturing agility to provide custom solutions, Fenner Drives Trantorque Keyless Bushings always deliver on this promise: The key to better machine design is no key at all!

## TABLE OF CONTENTS

Selection Assistance .....	3	Engineering Information.....	9
Traditional Connection Methods .....	4	Hub Sizing.....	11
Why Go Keyless .....	5	Technical Data.....	12
Application Examples .....	6	Trantorque Installation Wrenches.....	26
Made To Order (MTO) .....	8	Application Data Sheet.....	27



### Trantorque® GT.....page 12

- Designed with external counter-torque flange
- Exceptional concentricity and ability to transmit bending loads
- Zinc plated for corrosion protection
- Limited axial movement during installation



### Trantorque EN.....page 17

- Trantorque GT or Trantorque Mini with Electroless Nickel plating
- Corrosion protection in washdown and hostile environments
- Exceptional concentricity and ability to transmit bending loads
- Limited axial movement during installation



### Trantorque Mini.....page 14

- Designed for shafts as small as 1/8" or 3mm
- Exceptional concentricity and ability to transmit bending loads
- Zinc plated for corrosion protection
- Limited axial movement during installation



### Trantorque SS.....page 20

- Trantorque GT or Trantorque Mini manufactured from 303 Stainless Steel
- Ultimate corrosion protection in washdown and hostile environments
- Exceptional concentricity and ability to transmit bending loads
- Limited axial movement during installation



### Trantorque OE.....page 15

- Exceptional concentricity and ability to transmit bending loads
- Limited axial movement during installation
- Minimal OD/ID ratio



### Trantorque NT.....page 24

- Designed specifically to eliminate axial movement completely during installation
- Exceptional concentricity and ability to transmit bending loads
- Zinc plated for corrosion protection



### Trantorque OE Mini.....page 16

- Designed for shafts as small as 1/8" or 3mm
- Exceptional concentricity and ability to transmit bending loads
- Limited axial movement during installation



### Trantorque S.....page 25

- Short units ideal for mounting narrow hub components
- Exceptional concentricity and ability to transmit bending loads
- Zinc plated for corrosion protection
- Limited axial movement during installation

## The Right Trantorque® for Your Application

Once you have decided that a keyless bushing is the right solution, your next big decision is which Trantorque® to choose. The table is designed to help make your selection process easier, but if you are ever in doubt, please contact a Fenner Drives Applications Engineer. We will be happy to guide you to the perfect keyless bushing solution.

SELECTION ASSISTANCE	Trantorque GT	Trantorque Mini	Trantorque OE	Trantorque OE Mini	Trantorque EN	Trantorque EN Mini	Trantorque SS	Trantorque SS Mini	Trantorque NT	Trantorque S
Shaft Size Range	5/8 – 3 in; 15 – 75mm	1/8 – 3/4 in; 3 – 17mm	11/16 – 1 1/2 in; 17 – 35mm	1/8 – 3/4 in; 3 – 17mm	5/8 – 3 in; 15 – 75mm	3/16 – 3/4 in; 5 – 17mm	5/8 – 3 in; 15 – 75mm	3/16 – 3/4 in; 5 – 17mm	3/16 – 2 in	3/16 – 1 3/4 in
Torque Transmission	146 – 1,500 ft lb; 180 – 2,000 Nm	100 – 1,500 in lb; 12 – 170 Nm	158 – 483 ft lb; 208 – 645 Nm	62 – 1,184 in lb; 7 – 135 Nm	73 – 750 ft lb; 90 – 1,000 Nm	50 – 750 in lb; 6 – 85 Nm	44 – 450 ft lb; 54 – 600 Nm	30 – 450 in lb; 4 – 46 Nm	6 – 1,050 ft lb	8 – 833 ft lb
Axial Movement	~0.075 in (1.9mm)	~0.045 in (1.1mm)	~0.075 in (1.9mm)	~0.045 in (1.1mm)	~0.075 in (1.9mm)	~0.045 in (1.1mm)	~0.075 in (1.9mm)	~0.045 in (1.1mm)	No	~0.075 in (1.9mm)
Self Centering	Yes	Yes	Yes	Yes	Yes	Yes	Yes	Yes	Yes	Yes
Concentricity	Excellent	Excellent	Excellent	Excellent	Excellent	Excellent	Excellent	Excellent	Excellent	Excellent
Balance	Excellent	Very Good	Excellent	Very Good	Excellent	Very Good	Excellent	Very Good	Very Good	Very Good
Self-Locking Tapers	Yes	Yes	Yes	Yes	Yes	Yes	Yes	Yes	Yes	Yes
Corrosion Treatment	Zinc Plating	Zinc Plating	Machine Oil	Machine Oil	Electroless Nickel Plating	Electroless Nickel Plating	Stainless Steel Construction	Stainless Steel Construction	Zinc Plating	Zinc Plating
Recessed Installation Without Counterbore	No	Yes	No	Yes	No	Yes	No	Yes	Yes	No
Overall Length Range	1 1/2 – 4 1/4 in; 19.1 – 63.5mm	3/8 – 3/4 in; 9.5 – 19.1mm	1 3/16 – 1 13/16 in; 30 – 44mm	3/4 – 1 1/8 in; 19 – 29mm	1 1/2 – 4 1/4 in; 38.1 – 108.0mm	3/4 – 1 3/8 in; 19.1 – 34.9mm	1 1/2 – 4 1/4 in; 38.1 – 108.0mm	3/4 – 1 3/8 in; 19.1 – 34.9mm	1 1/16 – 4 1/2 in	5/8 – 1 1/2 in
RoHS Compliant	Inch - No Metric - Yes	Inch - No Metric - Yes	Yes	Yes	Yes	Yes	Yes	Yes	No	No

# Fenner Drives Keyless Bushings

From the moment the wheel came into existence, man has been faced with the seemingly simple task of mounting his invention to a shaft so that something useful could be accomplished. Though it has been over 5,500 years since these rotating components have made their way into use, many designs still utilize mounting methods not much improved from the days of antiquity. These traditional connection methods include: interference fits (shrink or press), keys and keyways, splines and quick detachable bushings. In the sections that follow, we compare and contrast these component mounting techniques and explain the principles behind the ingenious Fenner Drives Keyless Bushing.

## Traditional Connection Methods

### Interference Fits (Shrink and Press)

A shrink fit is a procedure whereby heat is used to facilitate a mechanical interference fit between two pieces of metal, such as a steel shaft and hub. Extreme heat is applied to the hub, causing it to expand and increasing the size of its machined bore. The expanded hub is removed from the heat source and quickly positioned onto the shaft. As the hub cools, its bore contracts back to its original machined dimension, effectively “shrinking” the hub onto the shaft.

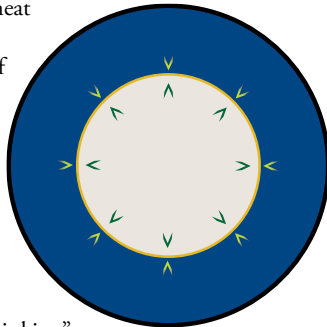

Shrink/Press

A press fit achieves the same end as a shrink fit — a mechanical interference fit between a steel shaft and hub — but does so through different means. Press fits rely on the application of simple brute force to “press” the hub onto the shaft.

Interference fits offer several advantages, such as zero backlash and uniform fit pressures, but these advantages come at a price. High capacity interference fits require long fit lengths, close tolerances, expensive and sometimes hazardous heat sources or hydraulic presses, and field maintenance is extremely difficult. Finally, separated components can rarely be re-used.

### Keys, Keyways & Splines

The centuries-old industry standard shaft-to-hub mounting technique is the key and keyway. While ubiquitous and intuitively easy to understand, the key and keyway is a remarkably ineffective technology. Machining a keyway into a shaft is not inexpensive, nor is the equipment required to do so, though these costs are often unknown or overlooked. Keyways introduce notch factors, which account for the reduced effective cross section and abridged fatigue life that occurs when a shaft is keyed and lead, in turn, to systematic over-sizing of shaft diameters. This translates to more shaft material and weight, larger bearings and other drive components, and increased cost.

Further, keyed connections require fit clearance for assembly, both between key and keyway and between shaft and hub.

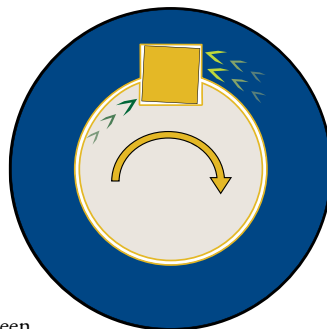

Key & Keyway

The combined effect of these clearances is backlash. In applications with frequent starts/stops, direction changes, and/or shock overloads, this backlash can lead to pounded out keyways, fatigue failures, fretting corrosion or some combination of these failure modes. Nor do keys and keyways lend themselves to motion control applications, since backlash erodes the accuracy of motion profiles over time.

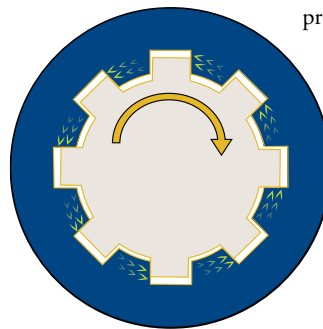

Spline

A splined connection is simply a series of keys and keyways that suffers the same limitations and drawbacks associated with a single keyed connection. Manufacturing costs are high, especially on hollow shafts, and special surface treatment is often required to increase strength.

### Keyed Bushing Systems

Both QD and Taper-Lock® bushing and weld-on hub systems are popular component mounting technologies, especially in North America. Yet both are ultimately keyed connections and as a result suffer from the same operational drawbacks as described above. As their name indicates, the weld-on hubs require an additional, and expensive, manufacturing step. And while the bushings can be used without a weld-on hub, doing so requires machining a taper and drilling and tapping holes in the mating part.

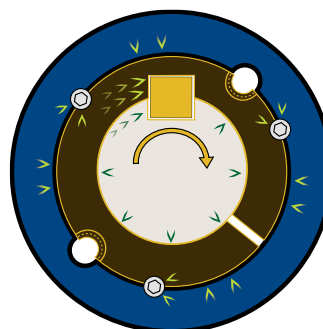

Taper-Lock

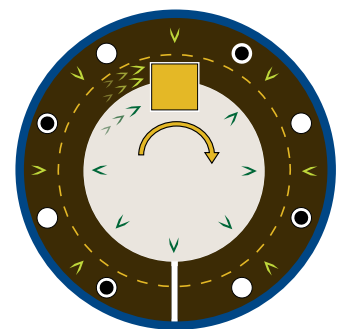

QD

## Why Go Keyless

Today's global marketplace demands precise, efficient machines that optimize productivity while minimizing material and fabrication costs. When compared to traditional connection methods, Fenner Drives Keyless Bushings offer the following advantages:

- A mechanical interference fit with a uniform pressure distribution similar to that achieved through a shrink or press fit.
- A true zero backlash shaft-to-hub connection with none of the operational drawbacks of keyways or splines.
- The ability to mount on plain shafting, which need not be over-sized to compensate for notch factors. This allows the use of smaller shafts and bearings for more cost effective designs.

### Principles of Operation

Though offered in many shapes and sizes, Fenner Drives Trantorque Keyless Bushings all operate using the simple wedge principle. An axial force is applied by the hex nut to engage circular steel rings with mating tapers. The resulting wedge action creates a radial force on the tapered rings, one of which then contracts to squeeze the shaft while the other expands and presses into the component bore.

The product of the radial force applied to the shaft, the radius of that shaft and the coefficient of friction between the surfaces being joined equals the rated torque capacity of the connection.

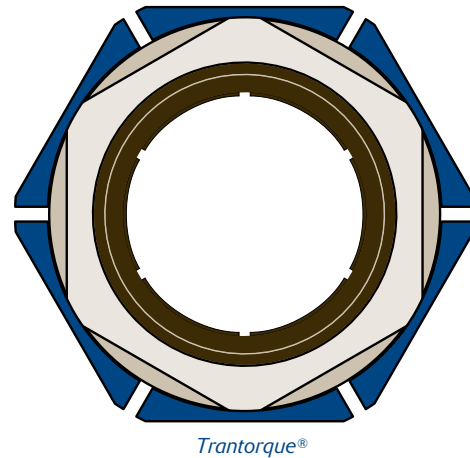

- The flexibility to mount over existing keyways if desired.
- Straight bore machining of the mounted component, generous machining tolerances and as-turned surface finishes.
- Complete axial and radial adjustability.
- Simple installation, adjustment and removal, even in the field.

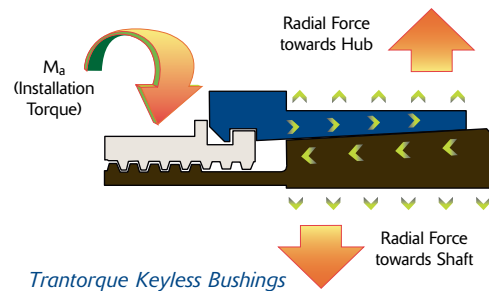

Comparison Chart	Trantorque	Interference Fit	Keyed Connection	Splined Connection	OD or TL Bushings
Keyless frictional connection	✱	•			
Infinite radial and axial adjustment	✱				
Easy installation	✱		•	•	•
Easy removal	✱				•
Backlash free connection	✱	•			
Transmits shock and torque reversals	✱	•			
Transmits reversing bending moments	✱	•			

## Fenner Drives Trantorque Keyless Bushings

Fenner Drives Keyless Bushings are perfectly suited for use in any industry where there is a need to mount a component to a shaft. Every day, our customers find unique uses for the engineering elegance of our keyless bushings. The application examples shown are just a small sampling of the many thousands of possible applications for Fenner Drives Keyless Bushings.



- 1 Trantorque GT connecting a timing pulley to shaft on a canning machine.
- 2 Trantorque GT mounts a roller chain sprocket to a keyless reducer output shaft.
- 3 Trantorque GT connects a synchronous belt pulley to rear wheel of hybrid vehicle (transparent view).
- 4 Trantorque OE ensures zero backlash on a rack and pinion drive.
- 5 Trantorque Mini provides a solution for mounting components in tight spaces on very small shafts, such as for this timing pulley on a linear slide.



# Trantorque®

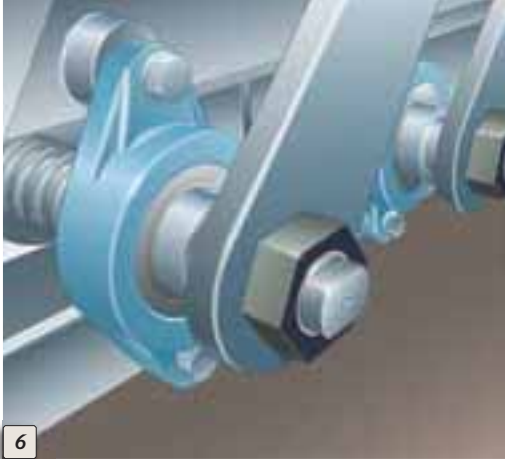

6



8

Application Illustrations by Mick Hill



7



9

6 Trantorque S positions a series of lever arms, greatly simplifying installation and timing.

7 The Trantorque GT units on this battling robot allowed the designers to eliminate keys and keyways, resulting in a lighter yet stronger machine.

8 Trantorque GT is perfect for high speed, low torque applications where balance is critical, as on this fan hub.

9 Trantorque NT allows worn conveyor rolls to be replaced quickly and easily.

10 This Trantorque GT — like all of our keyless bushings — features infinite radial positioning, making timing of this run-out table chain drive quick and easy.

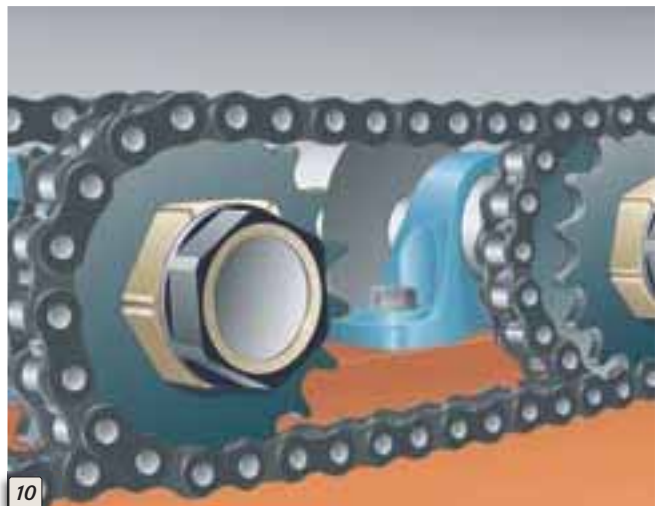

10

## Made to Order (MTO)

Fenner Drives offers a wide selection of standard keyless bushings to meet most shaft/component mounting needs. However, we realize that to be innovative in a global marketplace, today's engineers often require custom solutions. With unrivaled engineering expertise in keyless bushing design and material selection coupled with world class manufacturing capabilities, Fenner Drives is well positioned to offer Trantorque® MTO Keyless Bushings. From the ordinary to the extraordinary, our engineering team is ready to work with you. Together, we will develop a unique keyless bushing to meet your most demanding shaft/component mounting challenges.

Following are examples of some MTO building blocks that Fenner Drives has experience designing and working with. If you have an even more complex application, Fenner Drives New Product Development Group is ready to innovate with you.

**To facilitate working with our Applications Engineering Group on MTOs, please complete the Application Data Worksheet on page 27**

### Special Materials

All standard keyless bushings, with the exception of Trantorque SS, are made from either plain-carbon or low-alloy steels. Certain applications may require the use of other materials such as:

- Stainless steel
- EXP stainless steel (allows for higher torque transmission without the use of lubricants)
- Brass
- Tool steel

### Platings/Coatings

Special platings or coatings may be appropriate to deal with specific environmental or performance needs.

- Electroless nickel
- Chemical nickel
- Zinc
- Dacromet®
- TDC (Thin Dense Chromium) (Armoloy®)
- Teflon®

### Lubricants

The use of lubricants on threads and in some special cases, tapers, can have dramatic impact on keyless bushing properties.

- Light machine oil
- Synthetic grease
- FDA approved lubricants

### Designs

In addition to special materials, coatings and lubricants that can be used with existing designs, the Trantorque® fundamental architecture can be radically modified for special applications.

- Keyless bushings integrated into customer components
- Hand knobs in place of nuts
- Lips/flanges
- Grooves
- Common OD with differing ID series
- Non-standard IDs and ODs
- Long or short units



Image 1



Image 2



Image 3

**Image 1:** Trantorque® MTO designed for a blood centrifuge. The unit must be disassembled daily for cleaning and disinfecting. The knob allows easy disassembly without the use of tools.

**Image 2:** A positioning flange is machined both inside the bore and at the back of the outer clamping ring on this Trantorque MTO. The flanges guarantee perfect positioning when components are manipulated in the field.

**Image 3:** Shown actual size, this Trantorque MTO incorporates an extremely narrow clamping section that precisely matches the mounted component.



## SURFACE FINISH

Recommended surface finish for shafts and hub bores to be used with Fenner Drives Keyless Bushings is between .8 and 3.1 micro-meters RMS. A smoother finish — such as that found on components supplied TG&P (turned, ground and polished) — is NOT recommended and can result in a failure of the connection. Note that surface finishes below .8 micro-meters RMS can be roughened using longitudinal abrasion with a bastard file, emery paper or similar to achieve a surface finish within the recommended range.

## CONCENTRICITY

Fenner Drives Keyless Bushings are precision machined to maximize concentricity and minimize runout. The final installed concentricity of mounted components depends on several variables, including the components themselves and the installation technique employed. Overall, concentricity is typically excellent for Fenner Drives Keyless Bushings.

## SYNTHETIC DRIVE COMPONENTS

Fenner Drives Keyless Bushings are not recommended for use with most drive components constructed of synthetic polymers. An exception can be made if the component incorporates a reinforcing metal sleeve of sufficient size and strength. Please consult a Fenner Drives Applications Engineer regarding such applications.

## TEMPERATURE INFLUENCE

Similar to conventional shrink or press fits, connections using Fenner Drives Keyless Bushings are not affected by temperature changes as long as they apply equally to shaft and mating hub. Since temperatures above 204°C lower the strength of most commonly used materials, special considerations are necessary for connections working in temperatures exceeding 204°C.

## MOUNTING BEARINGS WITH FENNER DRIVES KEYLESS BUSHINGS

Mounting bearings with a Fenner Drives Keyless Bushing is not recommended. The expansion forces generated will distort the bearing's inner race, causing premature failure.

## ANAEROBIC ADHESIVES (THREADLOCKER)

Do not use anaerobic adhesives such as Loctite®, Permatex® or similar compounds with Fenner Drives Keyless Bushings. Doing so results in unknown contact pressures and capacities. Further, disassembly may be compromised when such compounds are applied to the keyless bushing, the shaft and/or the hub bore. Proper installation assures sufficient pre-load so that threads are self-locking, even in cases where the keyless bushing is subjected to extreme vibratory conditions.

## HOLLOW SHAFTS

Hollow shafts with bores exceeding 35% of outside diameter usually require a reduction of contact pressures in order to avoid permanent shaft deformation. Special considerations arise when installing Fenner Drives Keyless Bushings onto hollow shafts. Please consult with a Fenner Drives Applications Engineer for a trouble free hollow shaft connection.

## LUBRICANTS

Trantorque® OE and OE Mini Series are supplied unplated and lightly coated with ordinary machine oil. All other Trantorque units are supplied free of lubricant.

## MATERIALS

Trantorque Keyless Bushings are manufactured from carbon steel. For applications in corrosive environments, corrosion resistance can be improved through sealing with grease or silicone, the use of protective cover plates, application of industry standard plating materials (e.g., nickel, thin dense chromium, etc.) or by specifying the product in stainless steel (such as Trantorque SS) or other corrosion resistant materials. Please consult with a Fenner Drives Applications Engineer for more details.

## TORQUE

T = peak drive torque = nominal torque multiplied by a variable safety factor to account for stall or start-up conditions, mass accelerations, impact loads, etc. Nominal drive torque can be calculated as follows:

$$M_{\text{tnom}} (\text{Nm}) = \frac{9550 \times \text{kW}}{\text{rpm}}$$

Consult with a Fenner Drives Applications Engineer in cases where “T” is uncertain.

$M_t$  = The rated torque capacity of one Fenner Drives Keyless Bushing installed according to our instructions. Published torque capacities are calculated without using a safety factor and should be considered as the point where a connection could slip if a higher torque is applied. Therefore, always select a unit where  $M_t \geq T$ .

## MODIFIED INSTALLATION TORQUE

Torque capacity and contact pressures is a linear function of hex nut tightening torque ( $M_a$ ) and can be adjusted if necessary by reducing  $M_a$  up to 20%.

## THRUST

$T_h$  = transmissible thrust, determined by using the following equation:

$$T_h = \frac{2 \times M_t}{d}$$

where:  $d$  = shaft diameter

$M_t$  = unit torque rating

## TORQUE AND THRUST COMBINED

Simultaneous transmission of torque and thrust requires calculating a resultant torque:

$$M_{tres} = \sqrt{T^2 + \frac{(F \times d)^2}{2}}$$

where:  $T$  = peak drive torque

$F$  = peak thrust load

$d$  = shaft diameter

Select a unit where  $M_t \geq M_{tres}$ .

## BENDING MOMENTS

Bending moments are a crucial sizing factor in applications where a radial load from chain pull, the weight of components, etc., acts significantly outside the keyless bushing centerline. Typical applications include rolls or conveyor pulleys where shaft deflection due to radial loads results in a bending moment between shaft and end disc. Generally, bending moments change from a positive to a negative value during each rotation and are designated as rotating or reversing bending moments.

Fenner Drives Keyless Bushings are well suited to transmit rotating/reversing bending moments. Compiled using relevant data gleaned from numerous successful heavy-duty applications in conveyor pulleys as well as pertinent investigations by independent institutions,  $0.28 \times M_t$  bending moment capacity applies.

where:  $M_t$  = Rated torque capacity (from specification tables)

Consult with a Fenner Drives Applications Engineer on applications where the actual bending moment exceeds these recommended limits.

## TORQUE AND BENDING COMBINED

Simultaneous transmission of torque and bending requires calculating a resultant torque:

$$M_{tcb} = \sqrt{T^2 + (2 \times M_b)^2}$$

where:  $T$  = peak drive torque

$M_b$  = bending moment

Always select a unit where  $M_t \geq M_{tres}$  and  $M_{tcb}$  is within the limits appearing under [Bending Moments](#) above.

## RADIAL LOADS

Radial loads are generated when force is applied perpendicular to the centerline of the shaft and are frequently associated with pin or axle connections (see illustration below). Fenner Drives Keyless Bushings are well suited to provide tight, backlash-free connections for this type of application, as explained below.

$F_{rad}$  = radial load capacity =  $d \times L \times P_s$

where:  $d$  = shaft diameter

$D$  = hub bore

$L$  = contact length

$P_h$  = hub pressure

$P_s$  = shaft contact pressure =  $P_h \times \frac{D}{d}$

Typical pressure distribution in backlash-free pin connections

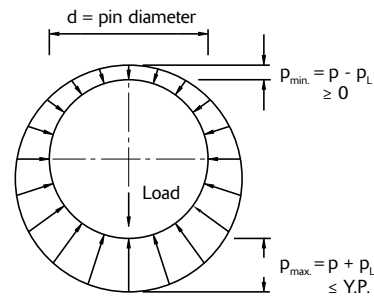

Explanations:

$p$  = contact pressure provided by keyless bushing

$p_L$  = contact pressure on projected contact area

$$= \frac{\text{load}}{d \times \text{contact length}}$$

Y.P. = yield point of pin material

## HUB SIZING

Fenner Drives Keyless Bushings transmit torque and other loads by means of mechanical interference generated by pressure exerted on both the shaft and mounted component hub. Therefore, consideration must be given to the amount of hub material (wall thickness) required to prevent permanent expansion (i.e., yielding). The following information is provided to assist you in determining the required hub diameter  $D_N$  for any keyless bushing application.

From the stress equations presented below, the required hub diameter  $D_N$  is determined as follows:

$$D_N = D \sqrt{\frac{Y.P. + (P_h \times C)}{Y.P. - (P_h \times C)}}$$

where:  $D$  = hub bore diameter (from product specifications)  
 $P_h$  = contact pressure applied to hub bore (from product specifications)  
 $Y.P.$  = tensile yield point of your hub material

And  $C$  is a Stress Reduction Factor which assumes the value of 1.0 or 0.8 depending upon the relationship of your actual hub width  $H_w$  to the contact length  $L$  of the keyless bushing selected. Use the illustrations at right to determine  $C$  for your application.

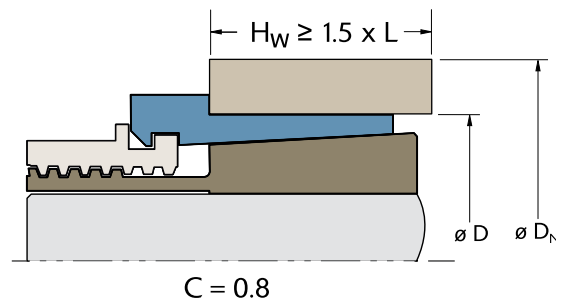
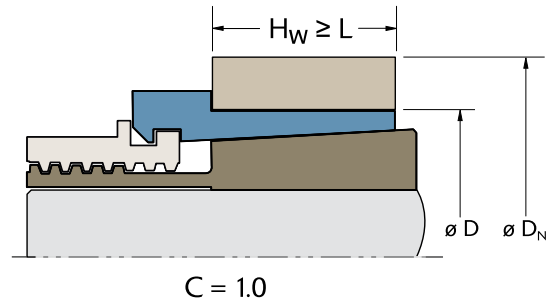

THICK WALLED CYLINDER SUBJECTED TO INTERNAL PRESSURE	TANGENTIAL STRESSES " $\sigma_t$ "	RADIAL STRESSES " $\sigma_r$ "	EXPANSION/ CONTRACTION
	$\sigma_{tx} = P \frac{Q}{1-Q} \left[ 1 + \frac{D_o^2}{d_x^2} \right]$ $\sigma_{ti} = P \frac{1+Q}{1-Q}$ $\sigma_{to} = 2P \frac{Q}{1-Q}$	$\sigma_{rx} = P \frac{Q}{1-Q} \left[ 1 - \frac{D_o^2}{d_x^2} \right]$ $\sigma_{ri} = -P$ $\sigma_{ro} = 0$	$\Delta d_i = Pd_i \frac{(v+1) + (v-1)Q}{vE(1-Q)}$ $\Delta D_o = 2P \frac{D_o Q}{E(1-Q)}$
THICK WALLED CYLINDER SUBJECTED TO EXTERNAL PRESSURE	TANGENTIAL STRESSES " $\sigma_t$ "	RADIAL STRESSES " $\sigma_r$ "	EXPANSION/ CONTRACTION
	$\sigma_{tx} = -\frac{P}{1-Q} \left[ 1 + \frac{d_i^2}{d_x^2} \right]$ $\sigma_{ti} = -\frac{2P}{1-Q}$ $\sigma_{to} = -P \frac{1+Q}{1-Q}$	$\sigma_{rx} = -\frac{P}{1-Q} \left[ 1 - \frac{d_i^2}{d_x^2} \right]$ $\sigma_{ri} = 0$ $\sigma_{ro} = -P$	$\Delta d_i = 2P \frac{d_i}{E(1-Q)}$ $\Delta D_o = PD_o \frac{(v-1) + (v+1)Q}{vE(1-Q)}$
KEY i = inside of hub o = outside of hub	v = poisson's ratio (.3003 for steel) E = modulus of elasticity (30 x 10 <sup>6</sup> for steel)	P = pressure $\tau$ = torsional hub stress	$Q = \left(\frac{d}{D}\right)^2$

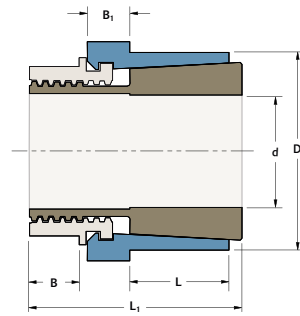
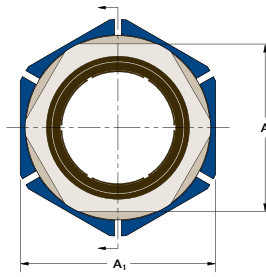
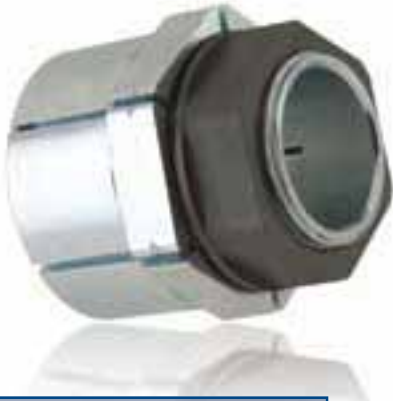

Trantorque GT metric sizes are plated with RoHS compliant clear Zinc.

TOLERANCE ( $T_1$ )

$T_1$  for shaft and bore is  $\pm .08\text{mm}$  for all sizes

### Trantorque GT Metric

Part Number	d (mm)	D (mm)	L (mm)	L <sub>1</sub> (mm)	A (mm)	A <sub>1</sub> (mm)	B (mm)	B <sub>1</sub> (mm)	M <sub>a</sub>	M <sub>t</sub>		P <sub>h</sub>	DN*	Shipping Weight (kg)
									Install Torque (Nm)	Maximum Transmitted				
								Torque (Nm)		Thrust (kN)	Hub Pressure (N/mm <sup>2</sup> )		Minimum Hub Diameter (mm)	
6202800	15	38.0	19.1	38.1	31.8	38.1	8.0	8.9	136	180	13.4	76	48.7	0.2
6202803	16	38.0	19.1	38.1	31.8	38.1	8.0	8.9	136	198	15.0	76	48.7	0.2
6202804	17	38.0	19.1	38.1	31.8	38.1	8.0	8.9	136	220	17.0	76	48.7	0.2
6202805	18	38.0	19.1	38.1	31.8	38.1	8.0	8.9	136	265	18.1	76	48.7	0.2
6202808	19	38.0	19.1	38.1	31.8	38.1	8.0	8.9	136	282	19.9	76	48.7	0.2
6202811	20	45.0	22.2	47.6	38.0	44.5	11.1	9.5	170	290	21.0	65	54.8	0.4
6202815	22	45.0	22.2	47.6	38.0	44.5	11.1	9.5	170	315	24.1	65	54.8	0.4
6202820	24	45.0	22.2	47.6	38.0	44.5	11.1	9.5	170	380	27.2	65	54.8	0.3
6202825	25	45.0	22.2	47.6	38.0	44.5	11.1	9.5	170	390	28.7	65	54.8	0.3
6202830	28	51.0	25.4	57.2	46.0	50.8	12.7	14.3	225	495	32.6	54	60.5	0.5
6202835	30	51.0	25.4	57.2	46.0	50.8	12.7	14.3	225	580	35.4	54	60.5	0.5
6202840	32	51.0	25.4	57.2	46.0	50.8	12.7	14.3	225	680	38.2	54	60.5	0.5
6202845	34	60.5	38.1	69.9	50.0	60.3	14.3	12.7	260	710	41.0	45	69.8	0.9
6202850	35	60.5	38.1	69.9	50.0	60.3	14.3	12.7	260	725	42.4	45	69.8	0.9
6202855	36	60.5	38.1	69.9	50.0	60.3	14.3	12.7	260	750	43.8	45	69.8	0.9
6202860	38	60.5	38.1	69.9	50.0	60.3	14.3	12.7	260	790	46.6	45	69.8	0.8
6202865	40	67.0	42.9	79.4	60.0	66.7	14.3	17.4	316	900	49.7	38	75.4	1.2
6202870	42	67.0	42.9	79.4	60.0	66.7	14.3	17.4	316	1000	53.3	38	75.4	1.1
6202876	45	73.0	50.8	90.5	65.0	73.0	15.9	19.1	554	1170	57.5	29	80.2	1.6
6202880	48	73.0	50.8	90.5	65.0	73.0	15.9	19.1	554	1355	62.9	29	80.2	1.6
6202885	50	73.0	50.8	90.5	65.0	73.0	15.9	19.1	554	1510	65.7	29	80.2	1.5
6202900	55	80.0	54.0	95.3	69.9	79.4	15.9	20.7	600	1650	67.8	24	85.8	1.8
6202910	60	86.0	57.2	98.4	75.0	85.7	17.5	19.1	635	1740	68.7	19	91.3	2
6202920	65	92.0	60.3	103.2	82.0	92.1	17.5	20.7	680	1930	69.5	17	97.2	2
6202930	70	92.0	60.3	103.2	82.0	92.1	17.5	20.7	680	1920	70.4	17	97.2	2
6202940	75	100.0	63.5	108.0	90.0	98.4	19.1	20.7	750	2000	71.5	16	97.2	3

\*Required hub OD for 1045 h.r. steel hub assuming 45 ksi Yield Point and Stress Reduction Factor C=1 (see page 11 for details)



TOLERANCE (T<sub>L</sub>)

T<sub>L</sub> for shaft and bore is ± .003\*  
for all sizes

**Trantorque GT Inch**

Part Number	d (inch)	D (inch)	L (inch)	L <sub>1</sub> (inch)	A (inch)	A <sub>1</sub> (inch)	B (inch)	B <sub>1</sub> (inch)	M <sub>a</sub>	M <sub>t</sub>	Th	P <sub>h</sub>	D <sub>N</sub> *	Shipping Weight (kg)
									Install Torque (ft lb)	Maximum Transmitted		Hub Pressure (psi)		
										Torque (ft lb)	Thrust (lbs)			
6202120	5/8	1 1/2	3/4	1 1/2	1 1/4	1 1/2	5/16	5/16	100	146	3300	11000	1.918	0.2
6202140	11/16	1 1/2	3/4	1 1/2	1 1/4	1 1/2	5/16	5/16	100	167	3850	11000	1.918	0.2
6202160	3/4	1 1/2	3/4	1 1/2	1 1/4	1 1/2	5/16	5/16	100	208	4400	11000	1.918	0.2
6202190	13/16	1 3/4	7/8	1 7/8	1 1/2	1 3/4	7/16	3/8	125	217	4950	9400	2.158	0.3
6202200	7/8	1 3/4	7/8	1 7/8	1 1/2	1 3/4	7/16	3/8	125	233	5500	9400	2.158	0.3
6202220	15/16	1 3/4	7/8	1 7/8	1 1/2	1 3/4	7/16	3/8	125	258	6050	9400	2.158	0.3
6202240	1	1 3/4	7/8	1 7/8	1 1/2	1 3/4	7/16	3/8	125	292	6600	9400	2.158	0.3
6202270	1 1/16	2	1	2 1/4	1 3/4	2	1/2	9/16	167	333	7000	7800	2.380	0.5
6202280	1 1/8	2	1	2 1/4	1 3/4	2	1/2	9/16	167	383	7500	7800	2.380	0.5
6202300	1 3/16	2	1	2 1/4	1 3/4	2	1/2	9/16	167	433	8000	7800	2.380	0.5
6202320	1 1/4	2	1	2 1/4	1 3/4	2	1/2	9/16	167	500	8500	7800	2.380	0.5
6202350	1 5/16	2 3/8	1 1/2	2 3/4	2	2 3/8	9/16	1/2	192	517	9000	6500	2.745	0.5
6202360	1 3/8	2 3/8	1 1/2	2 3/4	2	2 3/8	9/16	1/2	192	533	9500	6500	2.745	0.9
6202380	1 7/16	2 3/8	1 1/2	2 3/4	2	2 3/8	9/16	1/2	192	558	10000	6500	2.745	0.8
6202400	1 1/2	2 3/8	1 1/2	2 3/4	2	2 3/8	9/16	1/2	192	583	10500	6500	2.745	0.8
6202430	1 9/16	2 5/8	1 11/16	3 1/8	2 1/4	2 5/8	9/16	11/16	234	667	11000	5500	2.967	1.1
6202440	1 5/8	2 5/8	1 11/16	3 1/8	2 1/4	2 5/8	9/16	11/16	234	708	11750	5500	2.967	1.1
6202460	1 11/16	2 5/8	1 11/16	3 1/8	2 1/4	2 5/8	9/16	11/16	500	771	12250	5500	2.967	1.1
6202480	1 3/4	2 5/8	1 11/16	3 1/8	2 1/4	2 5/8	9/16	11/16	234	833	12750	5500	2.967	1.0
6202510	1 13/16	2 7/8	2	3 9/16	2 1/2	2 7/8	5/8	3/4	409	917	13250	4200	3.156	1.6
6202520	1 7/8	2 7/8	2	3 9/16	2 1/2	2 7/8	5/8	3/4	409	979	14000	4200	3.156	1.5
6202540	1 15/16	2 7/8	2	3 9/16	2 1/2	2 7/8	5/8	3/4	409	1063	14500	4200	3.156	1.5
6202560	2	2 7/8	2	3 9/16	2 1/2	2 7/8	5/8	3/4	409	1167	15000	4200	3.156	1.5
6202562	2 1/16	3 1/8	2 1/8	3 3/4	2 3/4	3 1/8	5/8	13/16	442	1188	15100	3500	3.378	1.7
6202564	2 1/8	3 1/8	2 1/8	3 3/4	2 3/4	3 1/8	5/8	13/16	442	1208	15200	3500	3.378	1.8
6202566	2 3/16	3 1/8	2 1/8	3 3/4	2 3/4	3 1/8	5/8	13/16	442	1229	15250	3500	3.378	1.7
6202568	2 1/4	3 1/8	2 1/8	3-3/4	2 3/4	3 1/8	5/8	13/16	442	1250	15275	3500	3.378	1.7
6202570	2 5/16	3 3/8	2 1/4	3-7/8	3	3 3/8	11/16	3/4	467	1271	15330	2800	3.592	2
6202572	2 3/8	3 3/8	2 1/4	3 7/8	3	3 3/8	11/16	3/4	467	1292	15400	2800	3.592	2
6202574	2 7/16	3 3/8	2 1/4	3 7/8	3	3 3/8	11/16	3/4	467	1313	15480	2800	3.592	2
6202576	2 1/2	3 3/8	2 1/4	3 7/8	3	3 3/8	11/16	3/4	467	1333	15550	2800	3.592	2
6202580	2 9/16	3 5/8	2 3/8	4 1/16	3 1/4	3 5/8	11/16	13/16	500	1354	15620	2400	3.824	2
6202582	2 5/8	3 5/8	2 3/8	4 1/16	3 1/4	3 5/8	11/16	13/16	500	1375	15680	2400	3.824	2
6202584	2 11/16	3 5/8	2 3/8	4 1/16	3 1/4	3 5/8	11/16	13/16	500	1396	15750	2400	3.824	2
6202586	2 3/4	3 5/8	2 3/8	4 1/16	3 1/4	3 5/8	11/16	13/16	500	1417	15800	2400	3.824	2
6202590	2 13/16	3 7/8	2 1/2	4 1/4	3 1/2	3 7/8	3/4	13/16	550	1438	15900	2300	4.078	3
6202592	2 7/8	3 7/8	2 1/2	4 1/4	3 1/2	3 7/8	3/4	13/16	550	1458	15950	2300	4.078	3
6202594	2 15/16	3 7/8	2 1/2	4 1/4	3 1/2	3 7/8	3/4	13/16	550	1479	16025	2300	4.078	3
6202596	3	3 7/8	2 1/2	4 1/4	3 1/2	3 7/8	3/4	13/16	550	1500	16150	2300	4.078	2

\*Required hub OD for 1045 h.r. steel hub assuming 45 ksi Yield Point and Stress Reduction Factor C=1 (see page 11 for details)

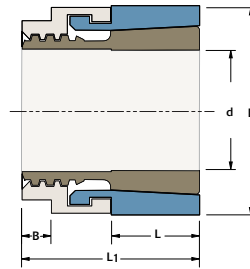
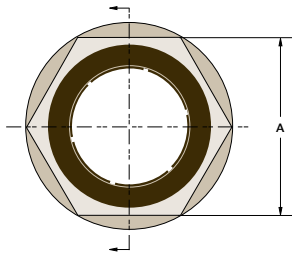

Trantorque Mini metric sizes are plated with RoHS compliant clear Zinc.

TOLERANCE ( $T_L$ )

$T_L$  for shaft and bore is  $\pm .04\text{mm}$  for all sizes

**Trantorque Mini Metric**

Part Number	d (mm)	D (mm)	L (mm)	L <sub>1</sub> (mm)	A (mm)	B (mm)	M <sub>a</sub>	M <sub>t</sub>	Th	P <sub>h</sub>	DN*	Shipping Weight (kg)
							Install Torque (Nm)	Maximum Transmitted		Hub Pressure (N/mm <sup>2</sup> )	Minimum Hub Diameter (mm)	
								Torque (Nm)	Thrust (kN)			
6202640	3	16.0	9.5	19.1	13.0	3.2	14.1	12	3.2	36	17.8	0.05
6202645	4	16.0	9.5	19.1	13.0	3.2	14.1	12	3.2	36	17.8	0.05
6202650	5	16.0	9.5	19.1	13.0	3.2	14.1	12	3.2	36	17.8	0.05
6202660	6	16.0	9.5	19.1	13.0	3.2	14.1	16	3.4	36	17.8	0.05
6202670	7	19.0	11.1	22.2	15.9	3.2	17	20	3.5	26	20.7	0.05
6202680	8	19.0	11.1	22.2	15.9	3.2	17	23	4.0	26	20.7	0.05
6202690	9	19.0	11.1	22.2	15.9	3.2	17	26	4.1	26	20.7	0.05
6202700	10	22.5	12.7	25.7	19.0	4.8	19.8	30	4.2	19	23.6	0.05
6202710	11	22.5	12.7	25.7	19.0	4.8	19.8	34	4.2	19	23.6	0.05
6202720	12	22.5	12.7	25.7	19.0	4.8	19.8	39	4.3	19	23.6	0.05
6202740	14	25.5	15.9	28.6	22.0	4.8	22.6	44	4.4	12	26.4	0.05
6202750	15	25.5	15.9	28.6	22.0	4.8	22.6	45	4.4	12	26.4	0.05
6202760	16	25.5	15.9	28.6	22.0	4.8	22.6	50	4.5	12	26.4	0.05
6202770	17	32.0	19.1	34.9	27.0	6.4	80	170	8.9	55	38.0	0.14



TOLERANCE ( $T_L$ )

$T_L$  for shaft and bore is  $\pm .0015''$  for all sizes

**Trantorque Mini Inch**

Part Number	d (inch)	D (inch)	L (inch)	L <sub>1</sub> (inch)	A (inch)	B (inch)	M <sub>a</sub>	M <sub>t</sub>	Th	P <sub>h</sub>	DN*	Shipping Weight (kg)
							Install Torque (in lb)	Maximum Transmitted		Hub Pressure (psi)	Minimum Hub Diameter (inch)	
								Torque (in lb)	Thrust (lbs)			
6202102	1/8	5/8	3/8	3/4	1/2	1/8	125	100	700	5200	0.702	0.1
6202103	3/16	5/8	3/8	3/4	1/2	1/8	125	100	700	5200	0.702	0.1
6202105	1/4	5/8	3/8	3/4	1/2	1/8	125	150	790	5200	0.702	0.1
6202107	5/16	3/4	7/16	7/8	5/8	1/8	150	200	890	3700	0.814	0.1
6202109	3/8	3/4	7/16	7/8	5/8	1/8	150	250	925	3700	0.814	0.1
6202110	7/16	7/8	1/2	1	3/4	3/16	175	300	950	2700	0.929	0.1
6202112	1/2	7/8	1/2	1	3/4	3/16	175	350	980	2700	0.929	0.1
6202114	9/16	1	5/8	1 1/8	7/8	3/16	200	400	990	1800	1.041	0.1
6202115	5/8	1	5/8	1 1/8	7/8	3/16	200	450	1000	1800	1.041	0.1
6202119	3/4	1 1/4	3/4	1 3/8	1 1/16	1/4	700	1500	2000	8000	1.494	0.1

\*Required hub OD for 1045 h.r. steel hub assuming 45 ksi Yield Point and Stress Reduction Factor C=1 (see page 11 for details)

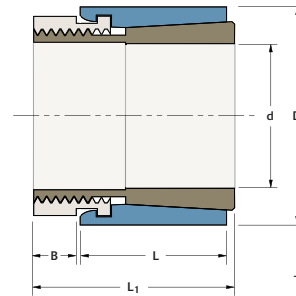
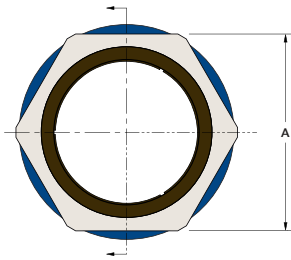

TOLERANCE ( $T_L$ )

$T_L$  for shaft and bore is  $\pm .08\text{mm}$  for all sizes

**Trantorque OE Metric**

Part Number	d (mm)	D (mm)	L (mm)	L <sub>1</sub> (mm)	A <sub>1</sub> (mm)	B <sub>1</sub> (mm)	M <sub>a</sub> Install Torque (Nm)	M <sub>t</sub> Maximum Transmitted		P <sub>h</sub> Hub Pressure (N/mm <sup>2</sup> )	D <sub>N</sub> * Minimum Hub Diameter (mm)	Shipping Weight (kg)
								Torque (Nm)	Thrust (kN)			
TTQM1732	17	32	22	30	30	6	110	208	25	92	43.5	0.1
TTQM1832	18	32	22	30	30	6	110	221	25	92	43.5	0.1
TTQM1932	19	32	22	30	30	6	110	233	25	92	43.5	0.1
TTQM2035	20	35	24	33	32	7	150	298	30	94	47.9	0.1
TTQM2235	22	35	24	33	32	7	150	328	30	94	47.9	0.1
TTQM2438	24	38	25	35	36	8	185	398	33	93	51.7	0.2
TTQM2538	25	38	25	35	36	8	185	415	33	93	51.7	0.2
TTQM2845	28	45	29	41	46	11	240	505	36	73	57.3	0.3
TTQM3045	30	45	29	41	46	11	240	541	36	73	57.3	0.3
TTQM3250	32	50	30	44	50	12	265	590	37	65	61.9	0.4
TTQM3550	35	50	30	44	50	12	265	645	37	65	61.9	0.3

TOLERANCE ( $T_L$ )

$T_L$  for shaft and bore is  $\pm .003$ " for all sizes

**Trantorque OE Inch**

Part Number	d (inch)	D (inch)	L (inch)	L <sub>1</sub> (inch)	A <sub>1</sub> (inch)	B <sub>1</sub> (inch)	M <sub>a</sub> Install Torque (ft lb)	M <sub>t</sub> Maximum Transmitted		P <sub>h</sub> Hub Pressure (psi)	D <sub>N</sub> * Minimum Hub Diameter (inch)	Shipping Weight (kg)
								Torque (ft lb)	Thrust (lbs)			
6410069	11/16	1 1/4	7/8	1 3/16	1 1/8	1/4	82	158	5517	13380	1.698	0.1
6410075	3/4	1 1/4	7/8	1 3/16	1 1/8	1/4	82	172	5517	13380	1.698	0.1
6410081	13/16	1 3/8	15/16	1 9/32	1 1/4	9/32	111	227	6713	13814	1.888	0.1
6410088	7/8	1 3/8	15/16	1 9/32	1 1/4	9/32	111	245	6713	13814	1.888	0.1
6410094	15/16	1 1/2	1	1 3/8	1 3/8	5/16	137	292	7471	13212	2.030	0.2
6410100	1	1 1/2	1	1 3/8	1 3/8	5/16	137	311	7471	13212	2.030	0.1
6410106	1 1/16	1 5/8	1 1/16	1 1/2	1 1/2	3/8	155	340	7686	11808	2.126	0.2
6410113	1 1/8	1 5/8	1 1/16	1 1/2	1 1/2	3/8	155	360	7686	11808	2.126	0.2
6410119	1 3/16	1 3/4	1 1/8	1 5/8	1 5/8	7/16	177	402	8114	10932	2.242	0.2
6410125	1 1/4	1 3/4	1 1/8	1 5/8	1 5/8	7/16	177	423	8114	10932	2.242	0.2
6410131	1 5/16	1 7/8	1 3/16	1 23/32	1 3/4	15/32	196	454	8301	9889	2.344	0.3
6410138	1 3/8	1 7/8	1 3/16	1 23/32	1 3/4	15/32	196	476	8301	9889	2.344	0.3
6410144	1 7/16	2	1 1/4	1 13/16	1 7/8	1/2	196	463	7723	8194	2.404	0.3
6410150	1 1/2	2	1 1/4	1 13/16	1 7/8	1/2	196	483	7723	8194	2.404	0.3

\*Required hub OD for 1045 h.r. steel hub assuming 45 ksi Yield Point and Stress Reduction Factor C=1 (see page 11 for details)

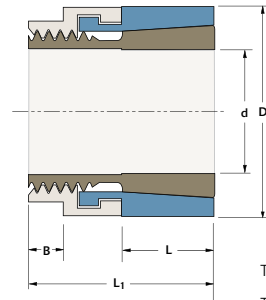
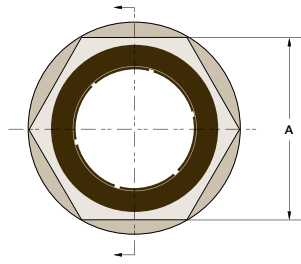

TOLERANCE ( $T_L$ )

$T_L$  for shaft and bore is  $\pm .04$ mm for all sizes

**Trantorque OE Mini Metric**

Part Number	d (mm)	D (mm)	L (mm)	L <sub>1</sub> (mm)	A <sub>1</sub> (mm)	B <sub>1</sub> (mm)	M <sub>a</sub>	M <sub>t</sub>	Th	P <sub>h</sub>	D <sub>N</sub> *	Shipping Weight (kg)
							Install Torque (Nm)	Maximum Transmitted		Hub Pressure (N/mm <sup>2</sup> )	Minimum Hub Diameter (mm)	
								Torque (Nm)	Thrust (kN)			
TTQM0316	3	16	10	19	13	3	10	7	4	73	20.3	0.02
TTQM0416	4	16	10	19	13	3	10	9	4	73	20.3	0.02
TTQM0516	5	16	10	19	13	3	10	11	4	73	20.3	0.02
TTQM0616	6	16	10	19	13	3	10	13	4	73	20.3	0.02
TTQM0720	7	20	11	22	16	3	28	35	10	119	30.0	0.03
TTQM0820	8	20	11	22	16	3	28	40	10	119	30.0	0.03
TTQM0920	9	20	11	22	16	3	28	45	10	119	30.0	0.03
TTQM1023	10	23	13	26	19	5	44	65	13	116	34.1	0.05
TTQM1123	11	23	13	26	19	5	44	72	13	116	34.1	0.05
TTQM1223	12	23	13	26	19	5	44	79	13	116	34.1	0.05
TTQM1426	14	26	16	29	22	5	66	118	17	107	37.3	0.06
TTQM1526	15	26	16	29	22	5	66	126	17	107	37.3	0.06
TTQM1626	16	26	16	29	22	5	66	135	17	107	37.3	0.06

TOLERANCE ( $T_L$ )

$T_L$  for shaft and bore is  $\pm .0015$ " for all sizes

**Trantorque OE Mini Inch**

Part Number	d (inch)	D (inch)	L (inch)	L <sub>1</sub> (inch)	A <sub>1</sub> (inch)	B <sub>1</sub> (inch)	M <sub>a</sub>	M <sub>t</sub>	Th	P <sub>h</sub>	D <sub>N</sub> *	Shipping Weight (kg)
							Install Torque (in lb)	Maximum Transmitted		Hub Pressure (psi)	Minimum Hub Diameter (inch)	
								Torque (in lb)	Thrust (lbs)			
6410013	1/8	5/8	3/8	3/4	1/2	1/8	90	62	1,000	11,316	0.808	0.1
6410019	3/16	5/8	3/8	3/4	1/2	1/8	90	94	1,000	11,316	0.808	0.1
6410025	1/4	5/8	3/8	3/4	1/2	1/8	90	125	1,000	11,316	0.808	0.1
6410031	5/16	3/4	7/16	7/8	5/8	1/8	250	351	2,245	18,147	1.150	0.1
6410038	3/8	3/4	7/16	7/8	5/8	1/8	250	421	2,245	18,147	1.150	0.1
6410044	7/16	7/8	1/2	1	3/4	3/16	390	645	2,946	17,864	1.332	0.1
6410050	1/2	7/8	1/2	1	3/4	3/16	390	737	2,946	17,864	1.332	0.1
6410056	9/16	1	5/8	1 1/8	7/8	3/16	585	1,066	3,790	16,084	1.453	0.1
6410063	5/8	1	5/8	1 1/8	7/8	3/16	585	1,184	3,790	16,084	1.453	0.1

\*Required hub OD for 1045 h.r. steel hub assuming 45 ksi Yield Point and Stress Reduction Factor C=1 (see page 11 for details)



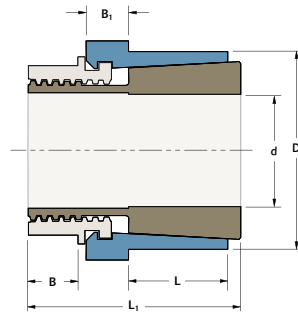
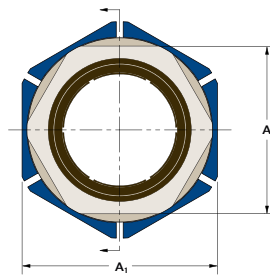

TOLERANCE (T<sub>L</sub>)

T<sub>L</sub> for shaft and bore is ± .08mm for all sizes

**Trantorque EN Metric**

Part Number	d (mm)	D (mm)	L (mm)	L <sub>1</sub> (mm)	A (mm)	A <sub>1</sub> (mm)	B (mm)	B <sub>1</sub> (mm)	M <sub>a</sub>	M <sub>t</sub>	Th	Ph	DN*	Shipping Weight (kg)
									Install Torque (Nm)	Maximum Transmitted		Hub Pressure (N/mm <sup>2</sup> )	Minimum Hub Diameter (mm)	
										Torque (Nm)	Thrust (kN)			
6202800EN	15	38.0	19.1	38.1	31.8	38.1	8.0	8.9	136	90	6.7	38	43.1	0.2
6202803EN	16	38.0	19.1	38.1	31.8	38.1	8.0	8.9	136	99	7.5	38	43.1	0.2
6202804EN	17	38.0	19.1	38.1	31.8	38.1	8.0	8.9	136	110	8.5	38	43.1	0.2
6202805EN	18	38.0	19.1	38.1	31.8	38.1	8.0	8.9	136	133	9.1	38	43.1	0.2
6202808EN	19	38.0	19.1	38.1	31.8	38.1	8.0	8.9	136	141	10.0	38	43.1	0.2
6202811EN	20	45.0	22.2	47.6	38.0	44.5	11.1	9.5	170	145	11.0	32	49.4	0.4
6202815EN	22	45.0	22.2	47.6	38.0	44.5	11.1	9.5	170	158	12.1	32	49.4	0.4
6202820EN	24	45.0	22.2	47.6	38.0	44.5	11.1	9.5	170	190	13.6	32	49.4	0.3
6202825EN	25	45.0	22.2	47.6	38.0	44.5	11.1	9.5	170	195	14.4	32	49.4	0.3
6202830EN	28	51.0	25.4	57.2	46.0	50.8	12.7	14.3	225	248	16.3	27	55.5	0.5
6202835EN	30	51.0	25.4	57.2	46.0	50.8	12.7	14.3	225	290	17.7	27	55.5	0.5
6202840EN	32	51.0	25.4	57.2	46.0	50.8	12.7	14.3	225	340	19.1	27	55.5	0.5
6202845EN	34	60.5	38.1	69.9	50.0	60.3	14.3	12.7	260	355	20.5	22	64.9	0.9
6202850EN	35	60.5	38.1	69.9	50.0	60.3	14.3	12.7	260	363	21.2	22	64.9	0.9
6202855EN	36	60.5	38.1	69.9	50.0	60.3	14.3	12.7	260	375	21.9	22	64.9	0.9
6202860EN	38	60.5	38.1	69.9	50.0	60.3	14.3	12.7	260	395	23.3	22	64.9	0.8
6202865EN	40	67.0	42.9	79.4	60.0	66.7	14.3	17.4	316	450	24.9	19	70.9	1.2
6202870EN	42	67.0	42.9	79.4	60.0	66.7	14.3	17.4	316	500	26.7	19	70.9	1.1
6202876EN	45	73.0	50.8	90.5	65.0	73.0	15.9	19.1	554	585	28.8	15	76.5	1.6
6202880EN	48	73.0	50.8	90.5	65.0	73.0	15.9	19.1	554	678	31.5	15	76.5	1.6
6202885EN	50	73.0	50.8	90.5	65.0	73.0	15.9	19.1	554	755	32.9	15	76.5	1.5
6202900EN	55	80.0	54.0	95.3	69.9	79.4	15.9	20.7	600	825	33.9	12	82.5	1.8
6202910EN	60	86.0	57.2	98.4	75.0	85.7	17.5	19.1	635	870	34.4	10	88.5	2
6202920EN	65	92.0	60.3	103.2	82.0	92.1	17.5	20.7	680	965	34.8	8	94.6	2
6202930EN	70	92.0	60.3	103.2	82.0	92.1	17.5	20.7	680	960	35.2	8	94.6	2
6202940EN	75	100.0	63.5	108.0	90.0	98.4	19.1	20.7	750	1000	35.8	8	101.0	3

\*Required hub OD for 1045 h.r. steel hub assuming 45 ksi Yield Point and Stress Reduction Factor C=1 (see page 11 for details)

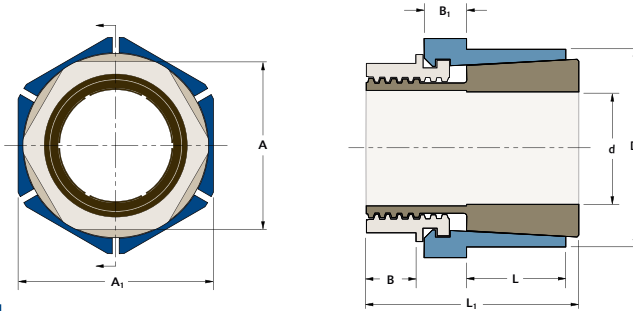

TOLERANCE ( $T_L$ )

$T_L$  for shaft and bore is  $\pm .003$ "  
for all sizes

**Trantorque EN Inch**

Part Number	d (inch)	D (inch)	L (inch)	L <sub>1</sub> (inch)	A (inch)	A <sub>1</sub> (inch)	B (inch)	B <sub>1</sub> (inch)	M <sub>a</sub>	M <sub>t</sub>	Th	P <sub>h</sub>	D <sub>N</sub> *	Shipping Weight (kg)
									Install Torque (ft lb)	Maximum Transmitted		Hub Pressure (psi)	Minimum Hub Diameter (inch)	
Torque (ft lb)	Thrust (lbs)													
6202120EN	5/8	1 1/2	3/4	1 1/2	1 1/4	1 1/2	5/16	5/16	100	73	1650	5500	1.696	0.2
6202140EN	11/16	1 1/2	3/4	1 1/2	1 1/4	1 1/2	5/16	5/16	100	83	1925	5500	1.696	0.2
6202160EN	3/4	1 1/2	3/4	1 1/2	1 1/4	1 1/2	5/16	5/16	100	104	2200	5500	1.696	0.2
6202190EN	13/16	1 3/4	7/8	1 7/8	1 1/2	1 3/4	7/16	3/8	125	108	2475	4700	1.943	0.3
6202200EN	7/8	1 3/4	7/8	1 7/8	1 1/2	1 3/4	7/16	3/8	125	117	2750	4700	1.943	0.3
6202220EN	15/16	1 3/4	7/8	1 7/8	1 1/2	1 3/4	7/16	3/8	125	129	3025	4700	1.943	0.3
6202240EN	1	1 3/4	7/8	1 7/8	1 1/2	1 3/4	7/16	3/8	125	146	3300	4700	1.943	0.3
6202270EN	1 1/16	2	1	2 1/4	1 3/4	2	1/2	9/16	167	167	3500	3900	2.182	0.5
6202280EN	1 1/8	2	1	2 1/4	1 3/4	2	1/2	9/16	167	192	3750	3900	2.182	0.5
6202300EN	1 3/16	2	1	2 1/4	1 3/4	2	1/2	9/16	167	217	4000	3900	2.182	0.5
6202320EN	1 1/4	2	1	2 1/4	1 3/4	2	1/2	9/16	167	250	4250	3900	2.182	0.5
6202350EN	1 5/16	2 3/8	1 1/2	2 3/4	2	2 3/8	9/16	1/2	192	258	4500	3250	2.553	0.7
6202360EN	1 3/8	2 3/8	1 1/2	2 3/4	2	2 3/8	9/16	1/2	192	267	4750	3250	2.553	0.7
6202380EN	1 7/16	2 3/8	1 1/2	2 3/4	2	2 3/8	9/16	1/2	192	279	5000	3250	2.553	0.7
6202400EN	1 1/2	2 3/8	1 1/2	2 3/4	2	2 3/8	9/16	1/2	192	292	5250	3250	2.553	0.7
6202430EN	1 9/16	2 5/8	1 11/16	3 1/8	2 1/4	2 5/8	9/16	11/16	234	333	5500	2750	2.791	1.0
6202440EN	1 5/8	2 5/8	1 11/16	3 1/8	2 1/4	2 5/8	9/16	11/16	234	354	5875	2750	2.791	1.0
6202460EN	1 11/16	2 5/8	1 11/16	3 1/8	2 1/4	2 5/8	9/16	11/16	234	385	6125	2750	2.791	1.0
6202480EN	1 3/4	2 5/8	1 11/16	3 1/8	2 1/4	2 5/8	9/16	11/16	234	417	6375	2750	2.791	1.0
6202510EN	1 13/16	2 7/8	2	3 9/16	2 1/2	2 7/8	5/8	3/4	409	458	6625	2100	3.012	1.4
6202520EN	1 7/8	2 7/8	2	3 9/16	2 1/2	2 7/8	5/8	3/4	409	490	7000	2100	3.012	1.4
6202540EN	1 15/16	2 7/8	2	3 9/16	2 1/2	2 7/8	5/8	3/4	409	531	7250	2100	3.012	1.4
6202560EN	2	2 7/8	2	3 9/16	2 1/2	2 7/8	5/8	3/4	409	583	7500	2100	3.012	1.4
6202562EN	2 1/16	3 1/8	2 1/8	3 3/4	2 3/4	3 1/8	5/8	13/16	442	594	7550	1750	3.249	1.7
6202564EN	2 1/8	3 1/8	2 1/8	3 3/4	2 3/4	3 1/8	5/8	13/16	442	604	7600	1750	3.249	1.7
6202566EN	2 3/16	3 1/8	2 1/8	3 3/4	2 3/4	3 1/8	5/8	13/16	442	615	7625	1750	3.249	1.7
6202568EN	2 1/4	3 1/8	2 1/8	3 3/4	2 3/4	3 1/8	5/8	13/16	442	625	7638	1750	3.249	1.7
6202570EN	2 5/16	3 3/8	2 1/4	3 7/8	3	3 3/8	11/16	3/4	467	635	7665	1400	3.482	1.9
6202572EN	2 3/8	3 3/8	2 1/4	3 7/8	3	3 3/8	11/16	3/4	467	646	7700	1400	3.482	1.9
6202574EN	2 7/16	3 3/8	2 1/4	3 7/8	3	3 3/8	11/16	3/4	467	656	7740	1400	3.482	1.9
6202576EN	2 1/2	3 3/8	2 1/4	3 7/8	3	3 3/8	11/16	3/4	467	667	7775	1400	3.482	1.9
6202580EN	2 9/16	3 5/8	2 3/8	4 1/16	3 1/4	3 5/8	11/16	13/16	500	677	7810	1200	3.723	2
6202582EN	2 5/8	3 5/8	2 3/8	4 1/16	3 1/4	3 5/8	11/16	13/16	500	688	7840	1200	3.723	2
6202584EN	2 11/16	3 5/8	2 3/8	4 1/16	3 1/4	3 5/8	11/16	13/16	500	698	7875	1200	3.723	2
6202586EN	2 3/4	3 5/8	2 3/8	4 1/16	3 1/4	3 5/8	11/16	13/16	500	708	7900	1200	3.723	2
6202590EN	2 13/16	3 7/8	2 1/2	4 1/4	3 1/2	3 7/8	3/4	13/16	550	719	7950	1150	3.975	3
6202592EN	2 7/8	3 7/8	2 1/2	4 1/4	3 1/2	3 7/8	3/4	13/16	550	729	7975	1150	3.975	3
6202594EN	2 15/16	3 7/8	2 1/2	4 1/4	3 1/2	3 7/8	3/4	13/16	550	740	8013	1150	3.975	3
6202596EN	3	3 7/8	2 1/2	4 1/4	3 1/2	3 7/8	3/4	13/16	550	750	8075	1150	3.975	3

\*Required hub OD for 1045 h.r. steel hub assuming 45 ksi Yield Point and Stress Reduction Factor C=1 (see page 11 for details)

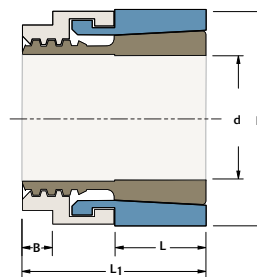
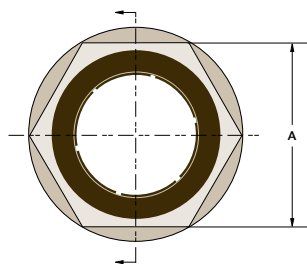

TOLERANCE ( $T_L$ )  
 $T_L$  for shaft and bore is  $\pm .04\text{mm}$   
for all sizes

**Trantorque EN Mini Metric**

Part Number	d (mm)	D (mm)	L (mm)	L <sub>1</sub> (mm)	A (mm)	B (mm)	M <sub>a</sub>	M <sub>t</sub>	Th	P <sub>h</sub>	DN*	Shipping Weight (kg)
							Install Torque (Nm)	Maximum Transmitted		Hub Pressure (N/mm <sup>2</sup> )	Minimum Hub Diameter (mm)	
								Torque (Nm)	Thrust (kN)			
6202650EN	5	16.0	9.5	19.1	13.0	3.2	14.1	6	1.6	18	16.9	0.05
6202660EN	6	16.0	9.5	19.1	13.0	3.2	14.1	8	1.7	18	16.9	0.05
6202670EN	7	19.0	11.1	22.2	15.9	3.2	17	10	1.8	13	19.9	0.05
6202680EN	8	19.0	11.1	22.2	15.9	3.2	17	12	2.0	13	19.9	0.05
6202690EN	9	19.0	11.1	22.2	15.9	3.2	17	13	2.1	13	19.9	0.05
6202700EN	10	22.5	12.7	25.7	19.0	4.8	19.8	15	2.1	9	22.9	0.05
6202710EN	11	22.5	12.7	25.7	19.0	4.8	19.8	17	2.1	9	22.9	0.05
6202720EN	12	22.5	12.7	25.7	19.0	4.8	19.8	20	2.2	9	22.9	0.05
6202740EN	14	25.5	15.9	28.6	22.0	4.8	22.6	22	2.2	6	25.9	0.05
6202750EN	15	25.5	15.9	28.6	22.0	4.8	22.6	23	2.2	6	25.9	0.05
6202760EN	16	25.5	15.9	28.6	22.0	4.8	22.6	25	2.3	6	25.9	0.05
6202770EN	17	32.0	19.1	34.9	27.0	6.4	22.6	85	4.5	28	34.8	0.14

TOLERANCE ( $T_L$ )  
 $T_L$  for shaft and bore is  $\pm .0015''$   
for all sizes

**Trantorque EN Mini Inch**

Part Number	d (inch)	D (inch)	L (inch)	L <sub>1</sub> (inch)	A (inch)	B (inch)	M <sub>a</sub>	M <sub>t</sub>	Th	P <sub>h</sub>	DN*	Shipping Weight (kg)
							Install Torque (in lb)	Maximum Transmitted		Hub Pressure (psi)	Minimum Hub Diameter (inch)	
								Torque (in lb)	Thrust (lbs)			
6202103EN	3/16	5/8	3/8	3/4	1/2	1/8	125	50	350	2600	0.662	0.1
6202105EN	1/4	5/8	3/8	3/4	1/2	1/8	125	75	395	2600	0.662	0.1
6202107EN	5/16	3/4	7/16	7/8	5/8	1/8	150	100	445	1850	0.781	0.1
6202109EN	3/8	3/4	7/16	7/8	5/8	1/8	150	125	463	1850	0.781	0.1
6202110EN	7/16	7/8	1/2	1	3/4	3/16	175	150	475	1350	0.902	0.1
6202112EN	1/2	7/8	1/2	1	3/4	3/16	175	175	490	1350	0.902	0.1
6202114EN	9/16	1	5/8	1 1/8	7/8	3/16	200	200	495	900	1.020	0.1
6202115EN	5/8	1	5/8	1 1/8	7/8	3/16	200	225	500	900	1.020	0.1
6202119EN	3/4	1 1/4	3/4	1 3/8	1 1/16	1/4	700	750	1000	4000	1.367	0.1

\*Required hub OD for 1045 h.r. steel hub assuming 45 ksi Yield Point and Stress Reduction Factor C=1 (see page 11 for details)

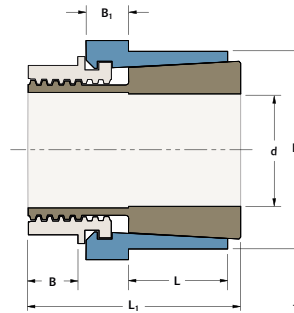
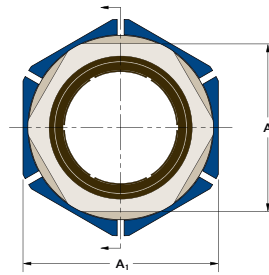

TOLERANCE ( $T_L$ )

$T_L$  for shaft and bore is  $\pm .08$ mm  
for all sizes

**Trantorque SS Metric**

Part Number	d (mm)	D (mm)	L (mm)	L1 (mm)	A (mm)	A1 (mm)	B (mm)	B1 (mm)	$M_a$	$M_t$	$T_h$	$P_h$	$D_N^*$	Shipping Weight (kg)
									Install Torque (Nm)	Maximum Transmitted		Hub Pressure (N/mm <sup>2</sup> )	Minimum Hub Diameter (mm)	
										Torque (Nm)	Thrust (kN)			
6990800	15	38.0	19.1	38.1	31.8	38.1	8.0	8.9	136	54	4.0	23	40.9	0.2
6990803	16	38.0	19.1	38.1	31.8	38.1	8.0	8.9	136	59	4.5	23	40.9	0.2
6990804	17	38.0	19.1	38.1	31.8	38.1	8.0	8.9	136	66	5.1	23	40.9	0.2
6990805	18	38.0	19.1	38.1	31.8	38.1	8.0	8.9	136	80	5.4	23	40.9	0.2
6990808	19	38.0	19.1	38.1	31.8	38.1	8.0	8.9	170	85	6.0	23	40.9	0.2
6990811	20	45.0	22.2	47.6	38.0	44.5	11.1	9.5	170	87	6.3	19	47.9	0.4
6990815	22	45.0	22.2	47.6	38.0	44.5	11.1	9.5	170	95	7.2	19	47.9	0.4
6990820	24	45.0	22.2	47.6	38.0	44.5	11.1	9.5	170	114	8.2	19	47.9	0.3
6990825	25	45.0	22.2	47.6	38.0	44.5	11.1	9.5	170	117	8.6	19	47.9	0.3
6990830	28	51.0	25.4	57.2	46.0	50.8	12.7	14.3	225	149	9.8	16	53.7	0.5
6990835	30	51.0	25.4	57.2	46.0	50.8	12.7	14.3	225	174	10.6	16	53.7	0.5
6990840	32	51.0	25.4	57.2	46.0	50.8	12.7	14.3	225	204	11.5	16	53.7	0.5
6990845	34	60.5	38.1	69.9	50.0	60.3	14.3	12.7	260	213	12.3	13	63.2	0.9
6990850	35	60.5	38.1	69.9	50.0	60.3	14.3	12.7	260	218	12.7	13	63.2	0.9
6990855	36	60.5	38.1	69.9	50.0	60.3	14.3	12.7	260	225	13.1	13	63.2	0.9
6990860	38	60.5	38.1	69.9	50.0	60.3	14.3	12.7	260	237	14.0	13	63.2	0.8
6990865	40	67.0	42.9	79.4	60.0	66.7	14.3	17.4	316	270	14.9	11	69.5	1.2
6990870	42	67.0	42.9	79.4	60.0	66.7	14.3	17.4	316	300	16.0	11	69.5	1.1
6990876	45	73.0	50.8	90.5	65.0	73.0	15.9	19.1	554	351	17.3	9	75.1	1.6
6990880	48	73.0	50.8	90.5	65.0	73.0	15.9	19.1	554	407	18.9	9	75.1	1.6
6990885	50	73.0	50.8	90.5	65.0	73.0	15.9	19.1	554	453	19.7	9	75.1	1.5
6990900	55	80.0	54.0	95.3	69.9	79.4	15.9	20.7	600	495	20.3	7	81.9	1.8
6990910	60	86.0	57.2	98.4	75.0	85.7	17.5	19.1	635	522	20.6	6	87.7	2
6990920	65	92.0	60.3	103.2	82.0	92.1	17.5	20.7	680	549	20.9	5	93.5	2
6990930	70	92.0	60.3	103.2	82.0	92.1	17.5	20.7	680	576	21.1	5	93.5	2
6990940	75	100.0	63.5	108.0	90.0	98.4	19.1	20.7	750	600	21.5	5	101.6	3

\*Required hub OD for 1045 h.r. steel hub assuming 45 ksi Yield Point and Stress Reduction Factor C=1 (see page 11 for details)

TOLERANCE (T<sub>1</sub>)

T<sub>1</sub> for shaft and bore is ± .003"  
for all sizes

## Trantorque SS Inch

Part Number	d (inch)	D (inch)	L (inch)	L <sub>1</sub> (inch)	A (inch)	A <sub>1</sub> (inch)	B (inch)	B <sub>1</sub> (inch)	M <sub>a</sub> Install Torque (ft lb)	M <sub>t</sub> Maximum Transmitted		P <sub>H</sub> Hub Pressure (psi)	D <sub>N</sub> * Minimum Hub Diameter (inch)	Shipping Weight (kg)
										Torque (ft lb)	Thrust (lbs)			
										Th	Th			
6990120	5/8	1 1/2	3/4	1 1/2	1 1/4	1 1/2	5/16	5/16	100	44	990	3300	1.614	0.2
6990140	11/16	1 1/2	3/4	1 1/2	1 1/4	1 1/2	5/16	5/16	100	50	1155	3300	1.614	0.2
6990160	3/4	1 1/2	3/4	1 1/2	1 1/4	1 1/2	5/16	5/16	100	63	1320	3300	1.614	0.2
6990190	13/16	1 3/4	7/8	1 7/8	1 1/2	1 3/4	7/16	3/8	125	65	1485	2820	1.863	0.3
6990200	7/8	1 3/4	7/8	1 7/8	1 1/2	1 3/4	7/16	3/8	125	70	1650	2820	1.863	0.3
6990220	15/16	1 3/4	7/8	1 7/8	1 1/2	1 3/4	7/16	3/8	125	78	1815	2820	1.863	0.3
6990240	1	1 3/4	7/8	1 7/8	1 1/2	1 3/4	7/16	3/8	125	88	1980	2820	1.863	0.3
6990270	1 1/16	2	1	2 1/4	1 3/4	2	1/2	9/16	167	100	2100	2340	2.107	0.5
6990280	1 1/8	2	1	2 1/4	1 3/4	2	1/2	9/16	167	115	2250	2340	2.107	0.5
6990300	1 3/16	2	1	2 1/4	1 3/4	2	1/2	9/16	167	130	2400	2340	2.107	0.5
6990320	1 1/4	2	1	2 1/4	1 3/4	2	1/2	9/16	167	150	2550	2340	2.107	0.5
6990350	1 5/16	2 3/8	1 1/2	2 3/4	2	2 3/8	9/16	1/2	192	155	2700	1950	2.480	0.5
6990360	1 3/8	2 3/8	1 1/2	2 3/4	2	2 3/8	9/16	1/2	192	160	2850	1950	2.480	0.9
6990380	1 7/16	2 3/8	1 1/2	2 3/4	2	2 3/8	9/16	1/2	192	168	3000	1950	2.480	0.8
6990400	1 1/2	2 3/8	1 1/2	2 3/4	2	2 3/8	9/16	1/2	192	175	3150	1950	2.480	0.8
6990430	1 9/16	2 5/8	1 11/16	3 1/8	2 1/4	2 5/8	9/16	11/16	234	200	3300	1650	2.723	1.1
6990440	1 5/8	2 5/8	1 11/16	3 1/8	2 1/4	2 5/8	9/16	11/16	234	213	3525	1650	2.723	1.1
6990460	1 11/16	2 5/8	1 11/16	3 1/8	2 1/4	2 5/8	9/16	11/16	234	231	3675	1650	2.723	1.1
6990480	1 3/4	2 5/8	1 11/16	3 1/8	2 1/4	2 5/8	9/16	11/16	234	250	3825	1650	2.723	1.0
6990510	1 13/16	2 7/8	2	3 9/16	2 1/2	2 7/8	5/8	3/4	409	275	3975	1260	2.957	1.6
6990520	1 7/8	2 7/8	2	3 9/16	2 1/2	2 7/8	5/8	3/4	409	294	4200	1260	2.957	1.5
6990540	1 15/16	2 7/8	2	3 9/16	2 1/2	2 7/8	5/8	3/4	409	319	4350	1260	2.957	1.5
6990560	2	2 7/8	2	3 9/16	2 1/2	2 7/8	5/8	3/4	409	350	4500	1260	2.957	1.5
6990562	2 1/16	3 1/8	2 1/8	3 3/4	2 3/4	3 1/8	5/8	13/16	442	356	4530	1050	3.200	1.7
6990564	2 1/8	3 1/8	2 1/8	3 3/4	2 3/4	3 1/8	5/8	13/16	442	363	4560	1050	3.200	1.8
6990566	2 3/16	3 1/8	2 1/8	3 3/4	2 3/4	3 1/8	5/8	13/16	442	369	4575	1050	3.200	1.7
6990568	2 1/4	3 1/8	2 1/8	3 3/4	2 3/4	3 1/8	5/8	13/16	442	375	4585	1050	3.200	1.7
6990570	2 5/16	3 3/8	2 1/4	3 7/8	3	3 3/8	11/16	3/4	467	381	4600	840	3.439	2.0
6990572	2 3/8	3 3/8	2 1/4	3 7/8	3	3 3/8	11/16	3/4	467	388	4620	840	3.439	2.0
6990574	2 7/16	3 3/8	2 1/4	3 7/8	3	3 3/8	11/16	3/4	467	394	4645	840	3.439	2.0
6990576	2 1/2	3 3/8	2 1/4	3 7/8	3	3 3/8	11/16	3/4	467	400	4665	840	3.439	1.9
6990580	2 9/16	3 5/8	2 3/8	4 1/16	3 1/4	3 5/8	11/16	13/16	500	406	4680	720	3.683	2
6990582	2 5/8	3 5/8	2 3/8	4 1/16	3 1/4	3 5/8	11/16	13/16	500	413	4705	720	3.683	2
6990584	2 11/16	3 5/8	2 3/8	4 1/16	3 1/4	3 5/8	11/16	13/16	500	419	4725	720	3.683	2
6990586	2 3/4	3 5/8	2 3/8	4 1/16	3 1/4	3 5/8	11/16	13/16	500	425	4740	720	3.683	2
6990590	2 13/16	3 7/8	2 1/2	4 1/4	3 1/2	3 7/8	3/4	13/16	550	431	4770	690	3.934	3
6990592	2 7/8	3 7/8	2 1/2	4 1/4	3 1/2	3 7/8	3/4	13/16	550	438	4785	690	3.934	3
6990594	2 15/16	3 7/8	2 1/2	4 1/4	3 1/2	3 7/8	3/4	13/16	550	444	4810	690	3.934	3
6990596	3	3 7/8	2 1/2	4 1/4	3 1/2	3 7/8	3/4	13/16	550	450	4845	690	3.934	3

\*Required hub OD for 1045 h.r. steel hub assuming 45 ksi Yield Point and Stress Reduction Factor C=1 (see page 11 for details)

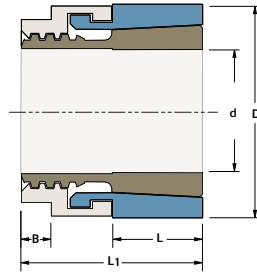
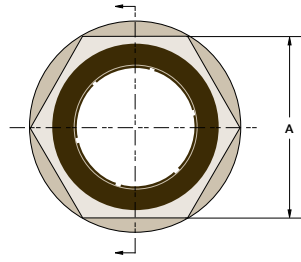

TOLERANCE ( $T_L$ )

$T_L$  for shaft and bore is  $\pm .04\text{mm}$   
 for all sizes

**Trantorque SS Mini Metric**

Part Number	d (mm)	D (mm)	L (mm)	L <sub>1</sub> (mm)	A (mm)	B (mm)	M <sub>a</sub>	M <sub>t</sub>	Th	Ph	DN*	Shipping Weight (kg)
							Install Torque (Nm)	Maximum Transmitted		Hub Pressure (N/mm <sup>2</sup> )	Minimum Hub Diameter (mm)	
Torque (Nm)	Thrust (kN)											
6990650	5	16.0	9.5	19.1	13.0	3.2	14.1	4	1.0	11	16.7	0.05
6990660	6	16.0	9.5	19.1	13.0	3.2	14.1	5	1.0	11	16.7	0.05
6990670	7	19.0	11.1	22.2	15.9	3.2	17	6	1.2	8	19.5	0.05
6990680	8	19.0	11.1	22.2	15.9	3.2	17	7	1.2	8	19.5	0.05
6990690	9	19.0	11.1	22.2	15.9	3.2	17	8	1.2	8	19.5	0.05
6990700	10	22.5	12.7	25.7	19.0	4.8	19.8	9	1.2	6	22.9	0.05
6990710	11	22.5	12.7	25.7	19.0	4.8	19.8	10	1.3	6	22.9	0.05
6990720	12	22.5	12.7	25.7	19.0	4.8	19.8	12	1.3	6	22.9	0.05
6990740	14	25.5	15.9	28.6	22.0	4.8	22.6	13	1.3	4	25.7	0.05
6990750	15	25.5	15.9	28.6	22.0	4.8	22.6	14	1.3	4	25.7	0.05
6990760	16	25.5	15.9	28.6	22.0	4.8	22.6	15	1.3	4	25.7	0.05
6990770	17	32.0	19.1	34.9	27.0	6.4	80	46	2.4	17	33.8	0.14

\*Required hub OD for 1045 h.r. steel hub assuming 45 ksi Yield Point and Stress Reduction Factor C=1 (see page 11 for details)

TOLERANCE (T<sub>L</sub>)

T<sub>L</sub> for shaft and bore is ± .0015"  
for all sizes

**Trantorque SS Mini Inch**

Part Number	d (inch)	D (inch)	L (inch)	L <sub>1</sub> (inch)	A (inch)	B (inch)	M <sub>a</sub>	M <sub>t</sub>	Th	P <sub>h</sub>	D <sub>N</sub> *	Shipping Weight (kg)
							Install Torque (in lb)	Maximum Transmitted		Hub Pressure (psi)	Minimum Hub Diameter (inch)	
								Torque (in lb)	Thrust (lbs)			
6990103	3/16	5/8	3/8	3/4	1/2	1/8	125	30	210	1560	0.647	0.1
6990105	1/4	5/8	3/8	3/4	1/2	1/8	125	45	235	1560	0.647	0.1
6990107	5/16	3/4	7/16	7/8	5/8	1/8	150	60	265	1110	0.769	0.1
6990109	3/8	3/4	7/16	7/8	5/8	1/8	150	75	280	1110	0.769	0.1
6990110	7/16	7/8	1/2	1	3/4	3/16	175	90	285	810	0.891	0.1
6990112	1/2	7/8	1/2	1	3/4	3/16	175	105	295	810	0.891	0.1
6990114	9/16	1	5/8	1 1/8	7/8	3/16	200	120	295	540	1.021	0.1
6990115	5/8	1	5/8	1 1/8	7/8	3/16	200	135	300	540	1.021	0.1
6990119	3/4	1 1/4	3/4	1 3/8	1 1/16	1/4	700	450	600	2400	1.319	0.1

\*Required hub OD for 1045 h.r. steel hub assuming 45 ksi Yield Point and Stress Reduction Factor C=1 (see page 11 for details)

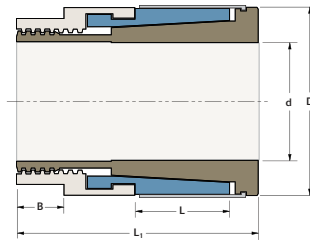
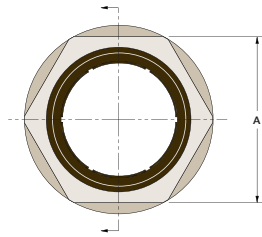
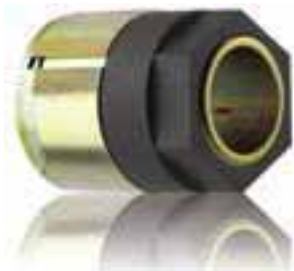

TOLERANCE ( $T_L$ )

Bore diameter machined to  $D \pm T_L$   
 $T_L = .0015''$  for Part Numbers  
 6980103 – 6980119  
 $T_L = .003''$  for all other Trantorque NT

**Trantorque NT Inch**

Part Number	d (inch)	D (inch)	L (inch)	L <sub>1</sub> (inch)	A (inch)	B (inch)	M <sub>a</sub>	M <sub>t</sub>	Th	Ph	DN*
							Install Torque (in lb)	Maximum Transmitted		Hub Pressure (psi)	Minimum Hub Diameter (inch)
								Torque (ft lb)	Thrust (lbs)		
6980103	3/16	5/8	3/8	1 1/16	1/2	1/8	125	6	490	3640	0.678
6980105	1/4	5/8	3/8	1 1/16	1/2	1/8	125	9	553	3640	0.678
6980107	5/16	3/4	7/16	1 3/16	5/8	1/8	150	12	623	2590	0.794
6980109	3/8	3/4	7/16	1 3/16	5/8	1/8	150	15	648	2590	0.794
6980110	7/16	7/8	1/2	1 5/16	3/4	3/16	175	18	665	1890	0.913
6980112	1/2	7/8	1/2	1 5/16	3/4	3/16	175	20	686	1890	0.913
6980114	9/16	1	5/8	1 7/16	7/8	3/16	200	23	693	1260	1.028
6980115	5/8	1	5/8	1 7/16	7/8	3/16	200	26	700	1260	1.028
6980119	3/4	1 1/4	3/4	1 11/16	1 1/16	1/4	700	88	1400	5600	1.417
6980120X	5/8	1 1/2	11/16	1 13/16	1 1/4	5/16	1200	102	2310	7700	1.783
6980140X	11/16	1 1/2	11/16	1 13/16	1 1/4	5/16	1200	117	2695	7700	1.783
6980160X	3/4	1 1/2	11/16	1 13/16	1 1/4	5/16	1200	146	3080	7700	1.783
6980190X	13/16	1 3/4	13/16	2 3/16	1 1/2	7/16	1500	152	3465	6850	2.040
6980200X	7/8	1 3/4	13/16	2 3/16	1 1/2	7/16	1500	163	3850	6850	2.040
6980220X	15/16	1 3/4	13/16	2 3/16	1 1/2	7/16	1500	181	4235	6850	2.040
6980240X	1	1 3/4	13/16	2 3/16	1 1/2	7/16	1500	204	4620	6850	2.040
6980270X	1 1/16	2	15/16	2 9/16	1 3/4	1/2	2000	233	4900	5460	2.259
6980280X	1 1/8	2	15/16	2 9/16	1 3/4	1/2	2000	268	5250	5460	2.259
6980300X	1 3/16	2	15/16	2 9/16	1 3/4	1/2	2000	292	5600	5460	2.259
6980320X	1 1/4	2	15/16	2 9/16	1 3/4	1/2	2000	350	5950	5460	2.259
6980350X	1 5/16	2 3/8	1 7/16	3 3/32	2	9/16	2300	362	6300	4550	2.629
6980360X	1 3/8	2 3/8	1 7/16	3 3/32	2	9/16	2300	373	6650	4550	2.629
6980380X	1 7/16	2 3/8	1 7/16	3 3/32	2	9/16	2300	391	7000	4550	2.629
6980400X	1 1/2	2 3/8	1 7/16	3 3/32	2	9/16	2300	408	7350	4550	2.629
6980430X	1 9/16	2 5/8	1 5/8	3 15/32	2 1/4	9/16	2800	467	7700	3850	2.860
6980440X	1 5/8	2 5/8	1 5/8	3 15/32	2 1/4	9/16	2800	496	8225	3850	2.860
6980460X	1 11/16	2 5/8	1 5/8	3 15/32	2 1/4	9/16	2800	540	8575	3850	2.860
6980480X	1 3/4	2 5/8	1 5/8	3 15/32	2 1/4	9/16	2800	583	8925	3850	2.860
6980510X	1 13/16	2 7/8	1 15/16	4 3/64	2 1/2	5/8	4900	642	9275	2940	3.069
6980520X	1 7/8	2 7/8	1 15/16	4 3/64	2 1/2	5/8	4900	685	9800	2940	3.069
6980540X	1 15/16	2 7/8	1 15/16	4 3/64	2 1/2	5/8	4900	744	10150	2940	3.069
6980560X	2	2 7/8	1 15/16	4 3/64	2 1/2	5/8	4900	817	10500	2940	3.069

\*Required hub OD for 1045 h.r. steel hub assuming 45 ksi Yield Point and Stress Reduction Factor C=1 (see page 11 for details)  
 Consult factory for weights and availability.



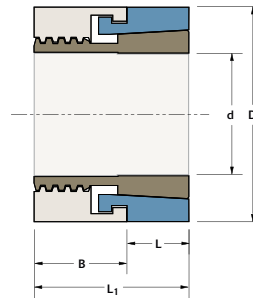
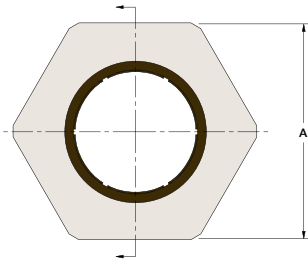

TOLERANCE ( $T_L$ )

Bore diameter machined to  $D \pm T_L$   
 $T_L = .0015"$  for Part Numbers  
 6940103 – 6940119  
 $T_L = .003"$  for all other Trantorque S

**Trantorque S Inch**

Part Number	d (inch)	D (inch)	L (inch)	L <sub>1</sub> (inch)	A (inch)	B (inch)	M <sub>a</sub>	M <sub>t</sub>	Th	Ph	DN*
							Install Torque (in lb)	Maximum Transmitted		Hub Pressure (psi)	Minimum Hub Diameter (inch)
								Torque (ft lb)	Thrust (lbs)		
6940103	3/16	5/8	1/4	5/8	5/8	3/8	125	8	700	7800	0.745
6940105	1/4	5/8	1/4	5/8	5/8	3/8	125	13	790	7800	0.745
6940107	5/16	3/4	1/4	5/8	3/4	3/8	150	17	890	6475	0.867
6940109	3/8	3/4	1/4	5/8	3/4	3/8	150	21	925	6475	0.867
6940110	7/16	7/8	3/8	3/4	7/8	3/8	175	25	950	3600	0.948
6940112	1/2	7/8	3/8	3/4	7/8	3/8	175	29	980	3600	0.948
6940114	9/16	1	3/8	7/8	1	1/2	200	33	990	3000	1.069
6940115	5/8	1	3/8	7/8	1	1/2	200	38	1000	3000	1.069
6940119	3/4	1 1/4	3/8	1	1 1/4	5/8	700	125	2000	16000	1.813
6940120	5/8	1 1/2	1/2	1 1/4	1 1/2	3/4	1200	146	3300	16500	2.203
6940140	1 1/16	1 1/2	1/2	1 1/4	1 1/2	3/4	1200	167	3850	16500	2.203
6940160	3/4	1 1/2	1/2	1 1/4	1 1/2	3/4	1200	208	4400	16500	2.203
6940190	13/16	1 3/4	1/2	1 1/4	1 3/4	3/4	1500	217	4950	16450	2.567
6940200	7/8	1 3/4	1/2	1 1/4	1 3/4	3/4	1500	233	5500	16450	2.567
6940220	15/16	1 3/4	1/2	1 1/4	1 3/4	3/4	1500	258	6050	16450	2.567
6940240	1	1 3/4	1/2	1 1/4	1 3/4	3/4	1500	292	6600	16450	2.567
6940270	1 1/16	2	1/2	1 1/4	2	3/4	2000	333	7000	15600	2.871
6940280	1 1/8	2	1/2	1 1/4	2	3/4	2000	383	7500	15600	2.871
6940300	1 3/16	2	1/2	1 1/4	2	3/4	2000	433	8000	15600	2.871
6940320	1 1/4	2	1/2	1 1/4	2	3/4	2000	500	8500	15600	2.871
6940350	1 5/16	2 3/8	1/2	1 1/2	2 1/4	1	2300	517	9000	19500	3.777
6940360	1 3/8	2 3/8	1/2	1 1/2	2 1/4	1	2300	533	9500	19500	3.777
6940380	1 7/16	2 3/8	1/2	1 1/2	2 1/4	1	2300	558	10000	19500	3.777
6940400	1 1/2	2 3/8	1/2	1 1/2	2 1/4	1	2300	583	10500	19500	3.777
6940430	1 9/16	2 5/8	1/2	1 1/2	2 1/2	1	2800	667	11000	18565	4.071
6940440	1 5/8	2 5/8	1/2	1 1/2	2 1/2	1	2800	708	11750	18565	4.071
6940460	1 11/16	2 5/8	1/2	1 1/2	2 1/2	1	2800	771	12250	18565	4.071
6940480	1 3/4	2 5/8	1/2	1 1/2	2 1/2	1	2800	833	12750	18565	4.071

\*Required hub OD for 1045 h.r. steel hub assuming 45 ksi Yield Point and Stress Reduction Factor C=1 (see page 11 for details)  
 Consult factory for weights and availability.

# Trantorque Installation Wrenches

Fenner Drives offers a complete line of high-quality crowfoot wrenches for use in the installation of Trantorque units. When installing a Trantorque GT, Trantorque EN or Trantorque SS unit, we recommend also using the U style for counter-torque.

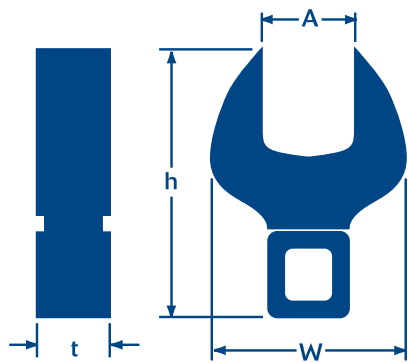

Style C  
Installation Nut

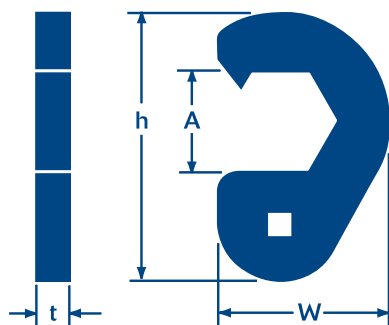

Style G  
Installation Nut

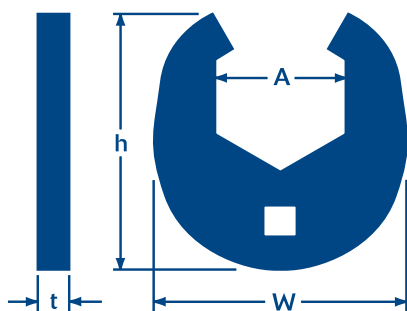

Style U  
Counter-Torque

## 1/2" Square Drive

Part Number	Shaft Size (inches)	Wrench Style	Dimensions (inches)			
			A	h	w	t
6202990020	5/8 – 3/4	C	1 1/4	2.88	2.25	0.60
6202990024U	5/8 – 3/4	U	1 1/2	4.91	4.88	0.31
6202990024	13/16 – 1	C	1 1/2	3.44	2.75	0.75
6202990028U	13/16 – 1	U	1 3/4	4.94	5.13	0.38
6202990028	1 1/16 – 1 1/4	C	1 3/4	3.50	3.25	0.52
6202990032U	1 1/16 – 1 1/4	U	2	5.68	5.37	0.50
6202990032	1 5/16 – 1 1/2	C	2	3.98	3.57	0.51
6202990038	1 5/16 – 1 1/2	U	2 3/8	5.93	5.75	0.50

## 3/4" Square Drive

Part Number	Shaft Size (inches)	Wrench Style	Dimensions (inches)			
			A	h	w	t
6202990036	1 9/16 – 1 3/4	G	2 1/4	6.64	4.38	0.75
6202990042	1 9/16 – 1 3/4	U	2 5/8	6.16	6.00	0.63
6202990040	1 13/16 – 2	G	2 1/2	6.89	4.63	0.75
6202990046	1 13/16 – 2	U	2 7/8	6.17	6.00	0.75
6202990044	2 1/16 – 2 1/4	G	2 3/4	7.20	4.34	0.75
6202990050	2 1/16 – 2 1/4	U	3 1/8	6.10	6.00	0.75
6202990048	2 5/16 – 2 1/2	G	3	7.88	5.03	0.75
6202990054	2 5/16 – 2 1/2	U	3 3/8	8.00	8.50	0.63
6202990052	2 9/16 – 2 3/4	G	3 1/4	8.57	5.72	0.75
6202990058	2 9/16 – 2 3/4	U	3 5/8	7.11	7.41	0.75
6202990056	2 13/16 – 3	G	3 1/2	9.32	5.72	0.75
6202990062	2 13/16 – 3	U	3 7/8	7.74	7.94	0.75

# Cuente con Fenner Drives.

Tenemos el producto adecuado para su aplicación.



**EAGLE**  
POLYURETHANE BELTING & O-RINGS

**PowerWist Plus**  
V-BELTS

**NUT LINK**  
V-BELTS

**SUPER T LINK**  
SP WEDGE BELTS

**DUNLOP**  
BELTING PRODUCTS

**T-MAX**  
BELT & CHAIN TENSIONERS

**PowerMax**  
PULLEYS & IDLERS

**Trantorque**  
Keyless Bushings

**Trackstar**  
UHMW BELT & CHAIN GUIDES

Fenner Drives es líder reconocido en el diseño y fabricación de componentes de transmisión de movimiento y de potencia para casos sencillos y complejos. Ampliamente reconocidos por nuestros conocimientos técnicos e innovación en tecnología de fabricación, combinamos eficazmente en nuestros productos fiabilidad, calidad y valor. Nuestras instalaciones, homologadas según ISO 9001:2000, se encuentran en Leeds (Reino Unido), Manheim (Pensilvania) y Wilmington (Carolina del Norte). Como parte de nuestro compromiso para proporcionar un servicio y un soporte técnicos insuperables, mantenemos unas amplias instalaciones de ingeniería, desarrollo y pruebas.

Visite nuestra página web: [www.fennerdrives.com](http://www.fennerdrives.com)



Hudson Road  
Leeds, LS9 7DF Reino Unido

[www.fennerdrives.com](http://www.fennerdrives.com)  
Tel.: +44 (0) 870 7577007  
Tel.: +44 (0) 113 2493486  
Fax: +44 (0) 113 2489656

311 West Stiegel Street  
Manheim, PA 17545-1747 EE. UU.

[www.fennerdrives.com](http://www.fennerdrives.com)  
Tel.: 800-243-3374  
Tel.: 717-665-2421  
Fax: 717-665-2649



**Trantorque**  
Casquillos sin Chaveta

### La unión perfecta entre cubo y eje

Desde engranajes a levas, desde poleas dentadas a rodillos de transportadores, de bujes de ventiladores de climatización a muelas, la amplia gama de casquillos sin chaveta Trantorque, todos con una sola tuerca de fijación, aporta opciones de fácil uso para montar y ajustar accesorios y componentes de accionamientos que necesiten un posicionamiento preciso sin holguras.

### Aproveche las ventajas exclusivas y de valor añadido que ofrecen los casquillos sin chaveta Trantorque.

- El diseño con una sola tuerca de fijación permite un montaje rápido y un preciso posicionamiento axial y radial de componentes
- Para reposicionar un componente sólo hay que aflojar y reapretar una sola tuerca, no una multitud de pequeños tornillos fáciles de perder
- Fácil montaje y fácil desmontaje: el diseño patentado garantiza que los casquillos no se griparán en los ejes
- La interferencia de montaje resiste cargas de choque e inversiones de par, ideal para uniones sin holgura circunferencial
- Elimina todos los problemas de inestabilidad de chaveta y corrosión por rozamiento propios de chaveteros y tornillos de fijación
- Sin mecanizado especial, sólo hay que cilindrar el componente con una tolerancia bastante amplia

## ¡Olvídense de las chavetas!

Cuando se montan y fijan componentes sobre un eje seguramente pensará en la solución tradicional: la chaveta, el chavetero y el tornillo de fijación. No obstante, durante el funcionamiento, el sistema de chaveta resulta frecuentemente en una transmisión de movimiento imprecisa, fallos prematuros y no poco tiempo oneroso de inactividad. Vea las útiles características de Trantorque:

- Tuerca de fijación única para una instalación y unos ajustes rápidos
- Equilibrio y concentricidad excelentes, gracias al mecanizado de precisión: todas las unidades son concéntricas en un rango de lectura total del indicador (TIR, en sus siglas en inglés) de 0,025 mm
- Diseños compactos con masa e inercia reducidas
- Adecuados para ejes con o sin chaveta
- Transmisión de par excepcional, incluso con sólo un encaje parcial de ejes
- Disponibles en varios materiales para protección anticorrosión

### Trantorque® M



- Serie compacta, ligera y totalmente métrica
- De gran rentabilidad
- Con baño anticorrosión, no recubiertos
- Para ejes desde 5 a 35 mm
- Cumple con la directiva RoHS 2002/95/CE.

### Trantorque® GT

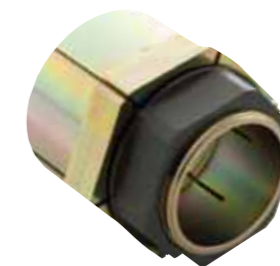

- Diseño original con brida antipar externa para facilitar la instalación
- Adecuados en muchas aplicaciones industriales generales
- Protección anticorrosión mediante recubrimiento
- Se pueden solicitar en opción acorde con la directiva RoHS
- Para ejes desde 5/8" a 3" y 15 a 75 mm

### Trantorque® MINI



- Ideal para el montaje de pequeños engranajes o poleas dentadas, y para componentes miniatura
- Sin brida antipar
- Protección anticorrosión mediante recubrimiento
- Se pueden solicitar en opción acorde con la directiva RoHS
- Para ejes desde 3/16" a 3/4" y de 5 a 17 mm

### Trantorque® NT

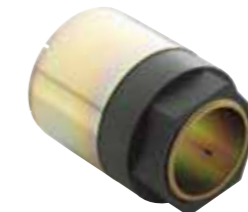

- Basados en el Trantorque GT y diseñados particularmente para evitar que se aplique esfuerzos axiales al componente montado
- Se pueden solicitar en opción con protección anticorrosión acorde con la directiva RoHS
- Para ejes desde 5/8" a 2 1/2" y de 15 a 60 mm

### Trantorque® S

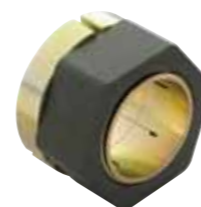

- Serie de casquillos acortados con las principales características de diseño de Trantorque GT
- La tuerca de fijación sobredimensionada y mecanizada con precisión garantiza que la superficie de montaje sea plana y perpendicular
- Ideal para espacios limitados y para ruedas dentadas de placa de montaje y otros componentes con bujes estrechos
- Se pueden solicitar en opción con protección anticorrosión acorde con la directiva RoHS
- Para ejes desde 3/16" a 1 3/4" y de 15 a 40 mm

### Trantorque® MTO



¿Tiene una aplicación que no admite una solución genérica? Podemos diseñarle un Trantorque desde cero para satisfacer las necesidades específicas de la aplicación.

El exclusivo, pero inherentemente simple, diseño Trantorque permite un alto grado de personalización. Por ejemplo, casquillos con mayor superficie interior, mayores diámetros exteriores con relación al tamaño estándar del hueco o casquillos con tuercas modificadas para aceptar otras herramientas de instalación: todo eso se puede diseñar fácilmente para satisfacer las necesidades específicas de la aplicación.

Se dispone de versiones niqueladas o en acero inoxidable con excelente resistencia a la corrosión.

Llámenos: nuestros recursos internos de ingeniería le esperan.

# Application Data Sheet

Please provide the details for your application on the form below and fax to +44 (0)113 2489656, email to ae@fennerdrives.com or call +44 (0)870 7577007. Our Applications Engineering team will review your application data and contact you with product recommendations.

**Contact Information**

Company Name \_\_\_\_\_

Address \_\_\_\_\_

City \_\_\_\_\_ Postal Code \_\_\_\_\_ Country \_\_\_\_\_

Contact \_\_\_\_\_ Title \_\_\_\_\_ Phone \_\_\_\_\_ Fax \_\_\_\_\_

E-mail \_\_\_\_\_ Web Address \_\_\_\_\_

**Torque/RPM/Application Details**

Nominal Running Torque \_\_\_\_\_

Peak Torque (if known) \_\_\_\_\_

Type of Prime Mover (motor, engine, etc.) \_\_\_\_\_

Type of Application (fan, conveyor, etc.) \_\_\_\_\_

Operating speed (RPM) at proposed connection \_\_\_\_\_

Input kW \_\_\_\_\_

Thrust Load \_\_\_\_\_

Radial Load \_\_\_\_\_

**Shaft Details (solid)**

Shaft Diameter (nominal/tolerance or actual measured) \_\_\_\_\_

Surface Material \_\_\_\_\_

Material (1020 steel, etc.) \_\_\_\_\_

Useable Length \_\_\_\_\_

Coatings (zinc, chrome, etc.) \_\_\_\_\_

**Shaft Details (hollow)**

Outside Diameter (nominal/tolerance or actual measured) \_\_\_\_\_

Inside Diameter \_\_\_\_\_

Surface Material \_\_\_\_\_

Material (1020 steel, etc.) \_\_\_\_\_

Useable Length \_\_\_\_\_

Coatings (zinc, chrome, etc.) \_\_\_\_\_

**Mounted Component Details**

Mounted Component (sprocket, gear, pulley, lever arm, coupling hub, etc.) \_\_\_\_\_

Component Material (steel, aluminum, etc.) \_\_\_\_\_

Material Yield Strength \_\_\_\_\_

Length thru Bore \_\_\_\_\_

Bore Diameter (if existing) \_\_\_\_\_

Bore Surface Finish \_\_\_\_\_

Component Hub Diameter \_\_\_\_\_

Coatings on shaft and/or component (zinc, chrome, etc.) \_\_\_\_\_

Thrust Load \_\_\_\_\_

**Operating Conditions**

Temperature Range \_\_\_\_\_

Oil/Chemicals \_\_\_\_\_

Washdown \_\_\_\_\_

Start/Stops \_\_\_\_\_

Frequency of assembly/disassembly \_\_\_\_\_

**Commercial Requirements**

Quantity Required \_\_\_\_\_

Annual Usage \_\_\_\_\_

**Trantorque Plating Requirements**

YES

Type:  RoHS Compliant (zinc clear)  RoHS (zinc yellow)

Black/Yellow zinc  Electroless Nickel

No Our standard oil dip will be supplied

**Comments/Attachments**

\_\_\_\_\_

\_\_\_\_\_

\_\_\_\_\_

\_\_\_\_\_

\_\_\_\_\_

\_\_\_\_\_

\_\_\_\_\_

\_\_\_\_\_

# Confíe en Fenner Drives.

Tenemos el producto adecuado para su aplicación.



**EAGLE**  
POLYURETHANE BELTING & O-RINGS

**POWERMAX PLUS**

**SUPERTLINK**  
SP WELDED BELTS

**NUTLINK**  
V-BELTS

**DUNLOP**  
BELTING PRODUCTS

**FMAX**  
BELT & CHAIN TENSIONERS

**PowerMax**  
PULLEYS & IDLERS

**Trantorque**  
Keyless Bushings

**B-LOC**  
Keyless Bushings

**Trackstar**  
UHMW BELT & CHAIN GUIDES

Fenner Drives es líder reconocido en el diseño y fabricación de componentes de transmisión de movimiento y de potencia para casos sencillos y complejos. Ampliamente reconocidos por nuestra experiencia y nuestra innovadora tecnología de fabricación, combinamos eficazmente en nuestros productos fiabilidad, calidad y valor. Nuestras instalaciones, homologadas según ISO 9001:2000, se encuentran en Leeds (Reino Unido), Manheim (Pensilvania) y Wilmington (Carolina del Norte). Como parte de nuestro compromiso para proporcionar un servicio y un soporte técnicos insuperables, disponemos de unas amplias instalaciones de ingeniería, desarrollo y pruebas.

Visite nuestra página web: [www.fennerdrives.com](http://www.fennerdrives.com)

 **Fenner Drives**  
an ISO 9001:2000 certified company

Hudson Road  
Leeds, LS9 7DF Reino Unido

[www.fennerdrives.com](http://www.fennerdrives.com)  
Tel.: +44 (0) 870 7577007  
Tel.: +44 (0) 113 2493486  
Fax: +44 (0) 113 2489656  
Correo electrónico: [sales@fennerdrives.com](mailto:sales@fennerdrives.com)

311 West Stiegel Street  
Manheim, PA 17545-1787  
USA

[www.fennerdrives.com](http://www.fennerdrives.com)  
Tel.: 800-243-3374  
Tel.: 717-665-2421  
FAX: 717-665-2649  
Correo electrónico:  
[info@fennerdrives.com](mailto:info@fennerdrives.com)

Sistemas  
Mecánicos  
**GAES**